

Audio Control Panel, Marker Beacon Receiver and Stereo Intercom System

30 \$ 700000 6



Installation and Operation Manual

FAA-Approved TSO C50c, C35d

Manufactured with pride by:

PS ENGINEERING[®]
INCORPORATED

Sound Quality. Sound Engineering

Document P/N 200-072-0004
Revision 4, Sept. 2000

PS Engineering, Inc. 2000 ©

Copyright Notice

Any reproduction or retransmittal of this publication, or any portion thereof, without the expressed written permission of PS Engineering, Inc. is strictly prohibited. For further information contact the Publications Manager at PS Engineering, Inc., 9800 Martel Road, Lenoir City, TN 37772. Phone (865) 988-9800

Table of Contents

1	SECTION I GENERAL INFORMATION	1-1
1.1	INTRODUCTION	1-1
1.2	SCOPE	1-1
1.3	EQUIPMENT DESCRIPTION	1-1
1.4	APPROVAL BASIS - FAA	1-2
1.5	SPECIFICATIONS	1-3
1.6	EQUIPMENT SUPPLIED	1-4
1.7	EQUIPMENT REQUIRED BUT NOT SUPPLIED	1-4
1.8	LICENSE REQUIREMENTS	1-4
2	SECTION II - INSTALLATION	2-1
2.1	GENERAL INFORMATION	2-1
2.1.1	SCOPE	2-1
2.2	UNPACKING AND PRELIMINARY INSPECTION	2-1
2.3	EQUIPMENT INSTALLATION PROCEDURES	2-1
2.3.1	COOLING REQUIREMENTS	2-1
2.3.2	MOUNTING REQUIREMENTS	2-1
2.3.3	MOUNTING RACK INSTALLATION	2-2
2.3.4	CONNECTOR ASSEMBLY	2-2
2.4	CABLE HARNESS WIRING	2-2
2.4.1	NOISE	2-2
2.4.2	EXISTING KMA-24 INSTALLATION	2-3
2.4.3	EXISTING PMA6000 INSTALLATIONS	2-3
2.4.4	POWER	2-4
2.4.5	RADIO PUSH-TO-TALK	2-4
2.4.6	TRANSMIT INTERLOCK	2-4
2.4.7	"SWAP" MODE FOR CIVIL AIR PATROL VERSIONS	2-4
2.4.8	BACKLIGHTING	2-5
2.4.9	UNSWITCHED INPUTS	2-5
2.4.10	INTERCOM WIRING	2-5
2.4.11	COM 3 AUDIO	2-6
2.4.12	PA MUTE (J1, PIN 18)	2-7
2.4.13	P-T-T INTERCOM (J2, PIN 18, L AND M)	2-7
2.5	MARKER INSTALLATION (PMA7000M-S)	2-7
2.5.1	MIDDLE MARKER SENSE (PMA7000M-S)	2-7
2.5.2	EXTERNAL MARKER LIGHTS (PMA7000M-S)	2-7
2.5.3	MARKER ANTENNA INSTALLATION	2-7
2.6	ADJUSTMENTS	2-7
2.7	COMMUNICATIONS ANTENNA INSTALLATION NOTES	2-8
2.8	POST INSTALLATION CHECKOUT	2-8
2.9	UNIT INSTALLATION	2-8
2.9.1	OPERATIONAL CHECKOUT	2-9
2.9.2	RECEIVER SENSITIVITY	2-10
2.10	FINAL INSPECTION	2-10
3	SECTION III OPERATION	3-1

PS Engineering
PMA7000M-S Series Audio Selector Panel and Intercom System
Civil Air Patrol Version Installation and Operator's Manual

3.1	SCOPE	3-1
3.2	AUDIO SELECTOR (ALL MODELS)	3-1
3.2.1	SPEAKER AMPLIFIER.....	3-2
3.3	POWER SWITCH (FAIL SAFE OPERATION)	3-2
3.4	MICROPHONE SELECTOR.....	3-2
3.5	SPLIT MODE	3-3
3.5.1	SPLIT MODE ICS.....	3-3
3.5.2	SWAP MODE.....	3-3
3.6	INTERCOM.....	3-4
3.6.1	INTELLIVOX®VOX-SQUELCH	3-4
3.6.2	VOLUME CONTROL	3-5
3.6.3	INTERCOM MODES.....	3-5
3.7	P-T-T INTERCOM MODE.....	3-7
3.8	MARKER BEACON (PMA7000M-S).....	3-7
4	<u>SECTION IV- WARRANTY AND SERVICE</u>	<u>4-1</u>
4.1	WARRANTY	4-1
4.2	FACTORY SERVICE.....	4-1
5	<u>APPENDIX A EXTERNAL PTT HOOK UP.....</u>	<u>A</u>
6	<u>APPENDIX B INSTALLATION DRAWING.....</u>	<u>B</u>
7	<u>APPENDIX C BOTTOM CONNECTOR INTERCONNECT</u>	<u>C</u>
8	<u>APPENDIX D TOP CONNECTOR INTERCONNECT</u>	<u>D</u>
9	<u>APPENDIX E-SUPPLEMENTAL WIRING PER CAP HEADQUARTERS.....</u>	<u>E</u>
10	<u>APPENDIX F - INSTRUCTIONS FOR FAA FORM 337 AND CONTINUING AIRWORTHINESS.....</u>	<u>F</u>
11	<u>APPENDIX G RTCA DO160C ENVIORNMENTAL QUALIFICATION FORM....</u>	<u>G</u>

Section I -- GENERAL INFORMATION

1.1 INTRODUCTION

The PMA7000M-S represents the next step in cockpit audio control and intercommunications. Using proprietary *IntelliVox*® design, this unit eliminates the requirements for intercom squelch adjustments. The unit is designed for outstanding ergonomics and visually defined mode annunciation and selection. These units were custom designed to meet the requirements of the Civil Air Patrol in the SAR environment.

Before installing and/or using this product, please read this manual completely. This will ensure that you will take full advantage of all the advanced features in the PMA7000M-S.

1.2 SCOPE

This manual provides detailed installation and operation instructions for the PS Engineering PMA7000M-S-units provided to the Civil Air Patrol:

<u>Model</u>	<u>Description</u>	<u>Part Number</u>
PMA7000S-CAP	Stereo Audio Panel with special CAP functions	7000S-CAP
PMA7000M-S-CAP	Stereo Audio Panel with Marker with special CAP functions	7000MS-CAP
Option 1 added to any unit	Same as above, with optional recorder and message system	Opt.1
Option 3 added to any system	Black bezel (no silver trim)	Opt 3
Other options may be applied for exclusive use by specific aircraft manufacturers, under Type Certification Call for information.		

1.3 EQUIPMENT DESCRIPTION

The PMA7000-series is a state-of-the-art audio isolation amplifier and audio selector that contains an automatic voice activated (VOX) intercom system. It can switch up to three transceivers (Com 1, Com 2 and Com 3) and five receivers (Nav 1, Nav 2, ADF, DME, and MKR).

There are two unswitched inputs, for autopilot disconnect, and/or radar altimeter warning. Push buttons select the receiver audio source provided to the headphones. A SPR button allows the user to listen to the receiver(s) selected on the cabin speaker. Except for the unswitched inputs, all speaker audio is muted during transmit.

A rotary switch selects one of the three communication transceivers for the pilot and copilot position, and allows radio transmission. In "Split Mode" the PMA7000M-S has the ability to allow the pilot and copilot to operate three different transceivers independently. In concert with the swap mode, six combinations of three transceivers are possible

A fail-safe mode connects the pilot headphone and microphone to COM 1 if power is removed for any reason, or if the power switch is placed in the Off (Fail-safe) position.

PS Engineering

PMA7000M-S Series Audio Selector Panel and Intercom System
Civil Air Patrol Version Installation and Operator's Manual

A six-station voice activated (VOX) intercom is included in the PMA7000-Series. This system has PS Engineering's exclusive *IntelliVox*® circuitry that eliminates manual adjustments. The system contains six separate VOX mic circuits, and only opens the microphone channel in use.

The intercom system incorporates pilot isolate and crew modes, two stereo music inputs with "Soft Mute," and LED indicators for swap and transmit indications. Intercom control is through front panel-mounted knob and 3-position mode switch. A single volume controls intercom level for the pilot and copilot. Passenger headphone volume is factory set, and adjusted in flight with headset-mounted volume controls. Passenger volume control is further adjustable through screwdriver access in the top of the unit. Intercom squelch is automatic.

A 3-light Marker Beacon receiver is integrated in the PMA7000M-S. This provides the necessary Marker Beacon lights and audio indications necessary for an Instrument Landing System (ILS) approach.

1.4 APPROVAL BASIS - FAA

TSO Approval.

The PMA7000M-S, and PMA7000S Audio Selector Panels are FAA approved under TSO C50c (Audio Amplifiers) and TSO C35d (Marker Beacon Receivers). In addition, they are approved by the Joint Airworthiness Authorities under JTSA C50C and JAR-TSO 2C35d.

All systems comply with relevant portions of EUROCAE RTCA MPS WG No. 7/70, DO-143 and (*Marker Beacon Receivers*), ED-14C/DO-160C (*Environmental Conditions and Test Procedures for Airborne Equipment*), ED12B/DO-178B (*Software Considerations for Airborne Equipment*) and ED- 18/DO-214 (*Audio Systems Characteristics and Minimum Operational Performance Standards for Aircraft Audio Systems*).

Operation is subject to the following conditions:

- This device may not cause harmful interference.
- This device must accept any interference received, including interference that may cause undesired operation.

1.5 SPECIFICATIONS

TSO COMPLIANCE	
<i>Marker Beacon:</i>	C35d, Class A
<i>Audio Selector/Intercom:</i>	C50c, Class A
APPLICABLE DOCUMENTS:	RTCA/DO-214 RTCA/DO-143 RTCA/DO-160C RTCA/DO-178B Level D
ENVIRONMENTAL Qualifications:	A1D1/CA(MN)XXXXXXBBBBTBKXX
<i>Temperature Range:</i>	
Operating:	-15° C to 55°C
Storage:	-20° C to 85°C
<i>Altitude:</i>	Up to 50,000 feet in a non-pressurized area of the cockpit.
DIMENSIONS:	Height: 1.3 in. (3.3 cm) Width: 6.25 in. (16.9 cm) Depth: 6.8 in. (17.3 cm)
WEIGHT (With Rack & Connectors):	1.5 lb. (0.54 kg)
POWER REQUIREMENTS (Including Internal Lighting):	
<i>Voltage:</i>	11 to 33 VDC
<i>Maximum Current:</i>	2.5 Amp (Externally protected by a 3 Amp circuit breaker.)
<i>Typical operating current:</i>	350 mA
Speaker off:	750 mA
Speaker on, 28V, full radio volume	2.5 A
Audio Selector Specifications	
<i>Audio selector panel input impedance:</i>	510 Ω
<i>Input Isolation:</i>	-60 dB (min.)
<i>Speaker Muting:</i>	-60 dB (min.)
<i>Speaker Output (into 4 Ω) with no clipping</i>	
14 VDC:	3 Watts (min.)
28 VDC:	10 Watts (min.)
<i>Receiver Inputs:</i>	8 (Com 1, Com 2, Com 3, Nav 1, Nav 2, ADF, DME, MKR)
<i>Unswitched Inputs:</i>	2 (examples: GPS WPT, Autopilot Disconnect, Altimeter DH)
<i>Transmitter Selections:</i>	9 (Com 1, Com 2, Com 3 Com1/Com2, Com 1/3, Com 2/3 and by swap switch, Com2/1, Com 3/1, Com 3/2)
<i>Speaker Impedance:</i>	4 Ω
<i>Headphone Impedance:</i>	150 - 1000 Ω
<i>Headphone Output:</i>	38 mW each headset, no clipping <1% THD 70 mW each headset with < 10% THD
<i>Microphone Impedance:</i>	150 - 600 Ω

PS Engineering
PMA7000M-S Series Audio Selector Panel and Intercom System
Civil Air Patrol Version Installation and Operator's Manual

Intercom Specifications	
<i>Intercom Positions:</i>	6 places (with individual <i>IntelliVox</i> ® circuits)
<i>Music Inputs:</i>	2 (Stereo)
<i>Music Muting:</i>	>-30 dB "Soft Mute" when Com or intercom active.
<i>Distortion:</i>	<1% THD @ 38 mW into 150Ω <10% THD @ 70mW into 150 Ω
<i>Mic Freq. Response, 3 dB:</i>	300 Hz - 6000 Hz
<i>Music Freq. Response, 3 dB:</i>	100 Hz - 18kHz
MARKER BEACON RECEIVER: PMA7000M-S only	
<i>Frequency:</i>	75 MHz Crystal Controlled
<i>Sensitivity:</i> Low: High:	Capable of: (preset at factory for field application) 1000 μVolts (Hard) 200 μVolts (Hard)
<i>Selectivity:</i>	-6 dB at ±10 kHz -40 dB at ±120 kHz
<i>External Lamp Output:</i>	9.0 (±1.5 at maximum brightness, unloaded) VDC positive when active, max. current 125 mA
<i>MM Sense:</i>	Active high (4.7 VDC ± 0.5V) during Middle Marker acquisition, for autopilot use.

1.6 EQUIPMENT SUPPLIED

1 ea. of the following units:

Model	Part Number
PMA7000S Special CAP version	7000S- CAP
PMA7000M-S Special CAP version with Marker Beacon Receiver	7000M-S- CAP

PMA7000M-S Installation Kit: 250-007-002

Part Number	Description	Quantity
120-430-0420	Tray Assembly	1
120-425-4400	Bottom connector, key between 7/8	1
120-425-4402	Top connector (Stereo), key between 5	1
655-000-0001	Gold Plated Crimp Pins	88
200-072-0004	Operator's and Installation Manual (CAP)	1
475-440-0007	#4 x 40 screw w/nylon patch	4

1.7 EQUIPMENT REQUIRED BUT NOT SUPPLIED

- a) Circuit Breaker: 1 ea. 3 amp (28V)
- b) Speaker, 4 Ω
- c) Stereo Headphone Jacks (as required)
- d) Microphone Jacks (as required)
- e) Stereo Headphones, 150 Ω, up to 6 as required
- f) Microphones, up to 6 as required
- g) Marker Antenna (75 MHz, VSWR <1:1.5, and appropriate for the airspeed)
- h) Interconnect Wiring

1.8 LICENSE REQUIREMENTS

None

Section II - Installation

2.1 GENERAL INFORMATION

2.1.1 SCOPE

This section provides detailed installation and interconnect instructions for the PS Engineering PMA7000M-Series Audio Selector Panel/Intercom System with internal Marker Beacon.

Please read this manual carefully before beginning any installation to prevent damage and post-installation problems. Installation of this equipment requires special tools and knowledge.

NOTE: An appropriately rated Certified Aircraft Repair Station **must** install this equipment in accordance with applicable regulations. PS Engineering, Incorporated warranty is not valid unless the equipment installation is supervised by an authorized PS Engineering, Incorporated dealer. Failure to follow any of the installation instructions or installation by a non-certified individual or agency will void the warranty, and may result in an unairworthy installation.

2.2 Unpacking and Preliminary Inspection

Use care when unpacking the equipment. Inspect the units and parts supplied for visible signs of shipping damage. Examine the unit for loose or broken buttons, bent knobs, etc. Verify the correct quantity of components supplied with the list in Section 1.6. If any claim is to be made, save the shipping material and contact the freight carrier. Do NOT return units damaged in shipping to PS Engineering. If the unit or accessories shows any sign of external shipping damage, contact PS Engineering to arrange for a replacement. Under no circumstances attempt to install a damaged unit in an aircraft. Equipment returned to PS Engineering for any other reason should be shipped in the original PS Engineering packaging, or other UPS approved packaging.

2.3 Equipment Installation Procedures

2.3.1 Cooling Requirements

Forced air cooling of the PMA7000M-S is not required. However the unit should be kept away from heat producing sources (i.e. defrost or heater ducts, dropping resistors, heat producing avionics) without adequate cooling air provided.

2.3.2 Mounting Requirements

The PMA7000M-S must be rigidly mounted to the instrument panel of the aircraft structure and within view and reach of the pilot position(s). Installation must comply with FAA Advisory Circular AC 43.13-2A. The unit may be mounted in any area where adequate clearance for the unit and associated wiring bundle exist.

Avoid installing the audio panel close to high current devices or systems with high-voltage pulse type outputs, such as DME or transponders.

2.3.3 Mounting Rack Installation

Remove the unit from the mounting tray by unscrewing the 3/32" hex-head screw that is in the center of the unit. Use caution to avoid hitting the photo-detector lens. Carefully slide the unit free of the tray. Set the unit aside in a safe location until needed. Install the tray using six FHP 6-32 x 1/2 screws. The audio selector panel must be supported at front and rear of the mounting tray.

<p>NOTE: The mounting hole configuration for the PMA7000M-S is identical to the PMA6000 series and KMA-24 Audio Selector Panels.</p>

2.3.4 Connector Assembly

The unit connectors mate directly with the circuit boards in the PMA7000M-S. The connectors are a Molex crimp-type, and require the use of a Molex hand crimp tool, EDP P/N 11-01-0203, CR6115B (or equiv.). The connectors are mounted to the unit tray with #4-40 screws, from the inside of the tray. Ensure that proper strain relief and chafing precautions are made during wiring and installation.

2.4 Tray Assembly

Attach the connectors to the tray from the inside, using the #4x40 screws provided. The bottom connector is keyed at pin 8, and top connector at pin 5. The lettered row of pins faces the top of the unit.

2.5 Cable Harness Wiring

Referring to the appropriate Appendix, assemble a wiring harness as required for the installation. All wires must be MIL-SPEC in accordance with current regulations. Two- and three-conductor with shield wire must be used where indicated, and be MIL-C-27500 or equivalent specification. Proper stripping, shielding and soldering technique must be used at all times. It is imperative that correct wire be used.

Refer to FAA Advisory Circular 43.13-2A for more information. Failure to use correct techniques may result in improper operation, electrical noise or unit failure. Damage caused by improper installation will void the PS Engineering warranty.

2.5.1 Noise

Due to the variety and the high power of radio equipment often found in today's general aviation aircraft, there is a potential for both radiated and conducted noise interference.

The PMA7000M-S power supply is specifically designed to reduce conducted electrical noise on the aircraft power bus by at least 50dB. Although this is a large amount of attenuation, it may

not eliminate all noise, particularly if the amplitude of noise is very high. There must be at least nominal aircraft voltage present at the bottom connector, pin 20, of the PMA7000M-S for the power supply to work in its designed regulation. Otherwise, it cannot adequately attenuate power line noise. Shielding can reduce or prevent radiated noise (i.e., beacon, electric gyros, switching power supplies, etc.) However, installation combinations can occur where interference is possible. The PMA7000M-S was designed in a RFI hardened chassis and has internal Electromagnetic Interference (EMI) filters on all inputs and outputs.

Ground loop noise occurs when there are two or more ground paths for the same signal (i.e., airframe and ground return wire). Large cyclic loads such as strobes, inverters, etc., can inject noise signals onto the airframe that are detected by the audio system. Follow the wiring diagram very carefully to help ensure a minimum of ground loop potential. Use only Mil Spec shielded wires (MIL-C-27500, or better).

Radiated signals can be a factor when low level microphone signals are "bundled" with current carrying power wires. Keep these cables physically separated. It is very important that you use insulated washers to isolate the ground return path from the airframe to **all** headphone and microphone jacks.

Adding a high-performance audio control system, particularly in conjunction with high-performance active noise canceling headsets, cannot improve on older avionics that were designed for cabin-speaker use. PS Engineering makes no claim that the audio panel will provide a noise-free audio quality under all installation conditions, particularly with older avionics.

2.5.2 Existing KMA-24 Installation

If the installation replaces a KMA-24 (part number -01, -02 or -03), the existing 44 pin connector can be used for the bottom connector of the PMA7000M-S tray as is, providing it is properly installed and wired. No other changes are required except for external marker lights (see Section 3.7.2 for details), OR unless additional transceivers must be added. The "key" in the existing connector must be located between pins 7 and 8. This connector will be used in the bottom connector position. (See Appendix C and D for complete wiring harness details.)

The existing ground bus may be reused for radio shield connections, if it was constructed so it can be relocated to the PMA7000M-S tray.

2.5.3 Existing PMA6000 installations

In 28-Volt aircraft, the dropping resistor may be removed; however, the 2 Amp breaker should be changed to 3 Amp. If the old unit is stereo (PMA6000S or PMA6000MS), no rewiring is necessary unless additional features are added.

2.5.3.1 Stereo PMA7000M-S installations into monaural PMA6000, PMA6000M.

Installations replacing PMA6000 or PMA6000M require re-wiring of the top connector to accommodate the stereo configuration. See appendix for detailed interconnect information.

2.5.4 Power

The PMA7000M-S-Series is compatible with both 14-and 28-Volt DC systems. A two- (2) Amp circuit breaker is required for 14 VDC installations, and a three- (3) Amp breaker for 28 VDC aircraft. Power and ground wires must be a twisted #18 AWG pair. Connect airframe power ground to J1 (bottom connector) Pin Z only. No dropping resistors are required.

2.5.5 Radio Push-to-Talk

An important part of the installation is the PTT (Push-To-Talk) switches that allow the use of your aircraft communications radio for transmissions. There are three typical configurations that can be used. Select the case that best fits the installation. Only the person who presses their PTT switch will be heard over the radio. If the pilot and copilot both use the PTT, the only pilot position has access to the radio. The pilot position will have PTT control regardless of the mic selector switch or copilot PTT when the PMA7000M-S is in the FAIL-SAFE mode.

CASE I: PTT is built into both pilot and copilot yokes.

CASE II: PTT is in pilot yoke only. This configuration requires a modified external PTT switch plugged into the copilot's microphone jack. (See Appendix A). When the copilot's PTT is pressed, the intercom switches the microphone audio from pilot to copilot mic.

CASE III: No built in PTT. This requires two built in PTTs to be installed, or modified external PTT switches to be used. Modify external PTT as required (See Appendix A).

Additional capability can be added to the PMA7000MS for observer or additional transmit stations. Contact PS Engineering for information

2.5.6 Transmit Interlock

Some communications transceivers use a transmit-interlock system. To fully utilize the Split Mode feature, this function must be disabled. Consult that equipment manufacturer's installation manual.

2.5.7 Required "Swap" Mode for Civil Air Patrol Versions

NOTE:

A SWAP switch is **REQUIRED** to access ALL of the CAP transceiver combinations

When a momentary, normally open, push-button switch is connected between pin 10 on the top connector and aircraft ground, the user can switch between various transceiver combinations. In the Com 1 or Com 2 position on the mic selector switch, the swap switch will change the selected transceiver to the opposite unit. For instance, if the mic selector is in Com 1, and the swap switch depressed, Com 1 is deselected and Com 2 selected.

In the PMA7000MS –CAP, the swap switch is active in the split mode. In the Com 1/2 mic selector position, depressing the Swap switch will place the pilot on Com 2, and the

copilot/observer on Com 1. Any combination shown on the mic selector switch can be reversed in this manner.

When the swap switch is active, the green "SWAP" LED illuminates on the PMA7000MS. This indicates that the mic selector position is no longer correct. Changing the mic selector will cancel the swap mode.

2.5.8 Backlighting

The PMA7000M-S has an automatic dimming of the pushbutton annunciator LEDs and marker lamps controlled by a photocell. Control of the unit backlighting is through the aircraft avionics dimmer. Connect the dimmer control line to J1 pin D for 14-volt systems, and to J1 pin F for 28-volt systems. Pin E is light ground.

If an external dimmer control is not used, a constant low level back light illumination can be established for nighttime viewing. Pin D or F (depending on system voltage) must be tied to power (J1, pin 20) for the back lighting system to work. The photocell mounted in the unit face will automatically adjust the intensity of the push-button annunciator LEDs.

2.5.9 Unswitched inputs

J1, pin T is the unswitched input number 1 and J1 pin 17 is unswitched input 2. These inputs are presented to the cockpit speaker pilot and copilot regardless of the audio configuration, and will always mute the entertainment inputs. These 510Ω inputs can be used for altimeter DH audio, GPS waypoint audio, autopilot disconnect tones, air-to-ground (Flitefone) telephone ringer or any other critical audio signal. This input is not related to the cellular telephone interface.

2.5.10 Intercom wiring

The top connector (J2) is for the intercom and additional functions. See Appendix for intercom connection configurations. It is critical to the proper operation of this system to have this connector wiring made in accordance with these diagrams. Use 2- and 3-conductor, MIL-spec cable as shown. Connect the shields at the audio panel end only, and tie to the audio low inputs as shown.

NOTE: The top connector harness can be custom made by PS Engineering, Inc. Simply call the factory and obtain a wire harness work-sheet. The harness will be made to your specifications and fully functionally tested. All hardware is included.

2.5.10.1 Entertainment Input

NOTE: Use the low-level output of any entertainment device to connect to the audio panel. Maximum signal level is **2 VAC** p-p.

DO NOT use a speaker-level output, this will cause internal damage in the audio panel.

2.5.10.1.1 Stereo entertainment

Two stereo entertainment devices (CD player, cassette player, etc.) can be connected to the unit. Install two $\frac{1}{8}$ -inch stereo jacks in a convenient location so that the pilot can plug in the entertainment devices into the system. The audio signal at the entertainment input must be a minimum of 500 mV P-P per channel for optimum music performance.

All entertainment devices must be switched **off** for both takeoff and landing.

2.5.10.1.2 Entertainment distribution

Entertainment source #1 provides music for the pilot and copilot positions, while entertainment source #2 provides music for the four passenger positions. The PMA7000M-S-system incorporates a "Soft Mute" system. This will mute the entertainment devices during ICS or radio conversation.

Any signal appearing in the unswitched audio inputs will always mute the entertainment sources, even though the passengers may not hear the audio tone itself.

Entertainment inputs #1 and #2 can be paralleled so a single entertainment source can serve both the passengers and the crew. It is suggested however, that a switch (DPDT) is installed between the single entertainment device and entertainment input #1. This will allow the pilot and copilot to decide if they hear entertainment while in the Crew mode.

Caution: Local oscillators and internal signals from some entertainment equipment can cause undesired interference with other aircraft systems. Before takeoff, operate the entertainment devices to determine if there is any adverse effect within the aircraft systems. If any unusual operation is noted in flight, immediately switch off the entertainment devices.

All entertainment devices must be switched off for both takeoff and landing.

2.5.10.1.3 Entertainment 2 Mute (Pin V)

The ICS button on the PMA7000M-S controls the muting ("Karoake mode") of entertainment source #1.

Connecting J2 pin V to ground through a SPST switch places the entertainment 2 music source into the Karoake Mode. In this mode, incoming music and intercom conversation will not mute the music for the passengers' intercom net. This allows uninterrupted music during casual conversation and at times when radio communications are of lessor importance.

2.5.11 Com 3 Audio

As installed in the standard configuration, the PMA7000M-S Com 3 audio is placed in the output when the mic selector switch is in the Com 3 position (fully CCW). Pushing the receiver selector buttons can monitor Com 1 Com 2 and Com 3 audio.

2.5.12 PA Mute (J1, Pin 18)

Pin 18 of J1 is TTL logic output that is pulled low during PTT operation. This serves as an input to external public address system to prevent feedback during transmissions.

2.5.13 P-T-T Intercom (J2, Pin 18, L and M)

To provide intercom in high noise environments, Pins L, 18 and M of the top connector can be used. Connect pin 18 to ground through a SPST switch to inhibit *IntelliVox*[™]. Connecting Pin M through a momentary switch to airframe ground will activate the pilot's microphone for intercom, grounding pin L will activate the copilot's microphone. For passengers to have PTT intercom, connect a momentary N.O. switch in series with mic audio.

2.6 Marker Installation (PMA7000M-S)

The marker beacon receiver is an option included in the PMA7000M-S.

NOTE:

Non-marker units can NOT provide audio interface with an external marker receiver through an auxiliary input.

2.6.1 Middle Marker Sense (PMA7000M-S)

A Middle Marker sense output signal is available from the 7000M and 7000M-S to flight control systems. This function will not operate during the test mode. This output will go to +4.75 VDC (± 0.25 VDC) when a valid Middle Marker signal is received. This output is J1, pin 2.

2.6.2 External Marker Lights (PMA7000M-S)

For installations that require external marker beacon lights, there are three outputs that can drive 12-Volt lamps only. The external output lamps are driven high (+9 VDC ± 1.5 VDC) when active. Maximum source current per lamp is 125 mA. Voltage varies with photocell dimming.

2.6.3 Marker Antenna Installation

Refer to aircraft and antenna manufacturer's installation instructions, as well as AC43.13-2A (or later revision), Chapter 3, for information on proper antenna installation techniques. The marker beacon antenna must be mounted on the bottom of the aircraft.

2.7 Adjustments

The PMA7000M-S is factory adjusted to accommodate the typical requirements for most aircraft configurations. There are five adjustments however, that will allow the installer to tailor the specific functions.

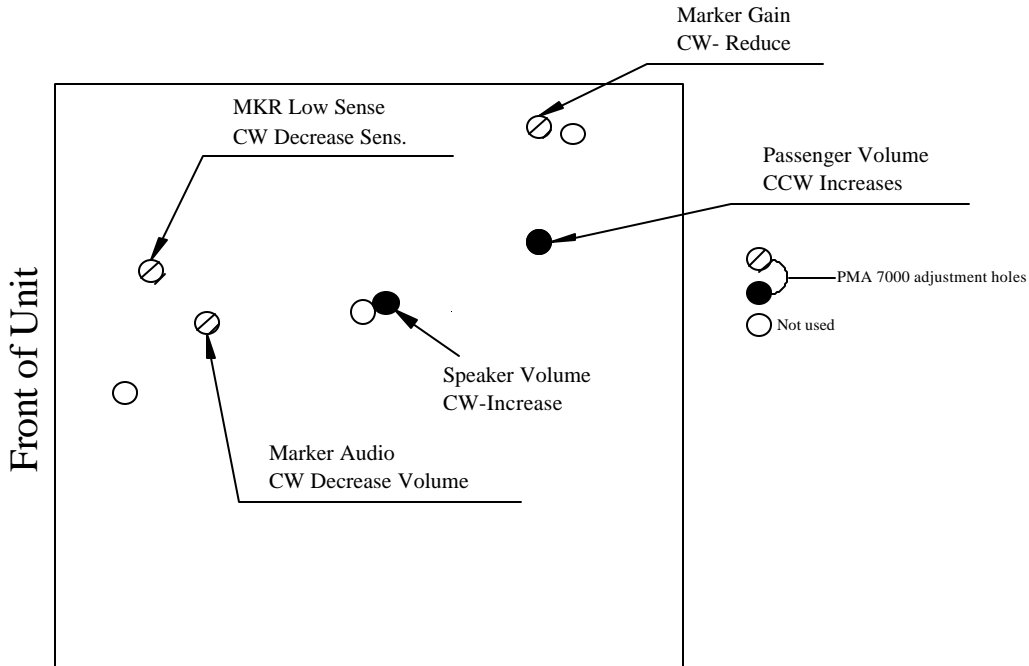

Figure 2-1- PMA7000M-S Adjustments

2.8 Communications Antenna Installation Notes

For best results while in Split Mode, it is suggested that the one VHF communications antenna is located on top of the aircraft while the other communications antenna is installed on the bottom. Any antenna relocation must be accomplished in accordance with AC 43.13-2A, aircraft manufacturers' recommendations and FAA-approved technical data.

Warning:

It is probable that radio interference will occur in the split mode when the frequencies of the two aircraft radios are adjacent, and/or the antennas are physically close together. PS Engineering makes no expressed or implied warranties regarding the suitability of the PMA7000M-S in Split Modes.

2.9 Post Installation Checkout

After wiring is complete, verify power is ONLY on pin 20 of the J1 (bottom connector) (dim power may also be at Pin D and F), and airframe ground on bottom connector pin Z. Failure to do so will cause serious internal damage and void PS Engineering's warranty.

2.10 Unit Installation

To install the PMA7000M-S, gently slide the unit into the mounting rack until the hold-down screw is engaged. While applying gentle pressure to the face of the unit, tighten the 3/32" hex-head in the center of the unit until it is secure. **DO NOT OVER TIGHTEN.**

Warning: Do not over-tighten the lock down screw while installing the unit in tray. **Internal damage will result.**

2.10.1 Operational Checkout

1. Apply power to the aircraft and avionics.
2. Plug headsets into the pilot, copilot, and occupied passenger positions.
3. Rotate the Mic Selector Switch to the **Com 1** position.
4. Verify that the **Com 1** button lights. Verify that the green transmit LED (Light Emitting Diode) near the mic selector is not illuminated. If the LED is on, stop testing and troubleshoot the microphone PTT installation.
5. Verify proper transmit and receive operation from the copilot position, noting that the copilot PTT switch allows proper transmission on the selected transceiver.
6. Verify that pushing the **COM 2** button causes the button to illuminate, and the Com 2 receiver to be heard. Verify operation on Com 1 from the pilot position.
7. Repeat for Com 2 and Com 3, (if installed).
8. Rotate the mic selector switch to the **COM 1/2** position. Verify that the pilot communicates on Com 1 and the copilot on Com 2.
9. Rotate the mic selector switch to the **COM 1/3** position. Verify that the pilot communicates on Com 1 and the copilot on Com 3.
10. Rotate the mic selector switch to the **COM 2/3** position. Verify that the pilot communicates on Com 2 and the copilot on Com 3.
11. Verify that the external swap switch causes the swap LED to illuminate, and reverses the transceiver in use indicated on the mic selector.
12. Verify proper operation of all receiver sources by selecting them using the button. Note that the button for the receiver sources stays in, and the button illuminates to show which source is in use.
13. Push in the S (SPR) button. Verify that all selected audio is heard in the cockpit speaker. Verify that the audio mutes when the mic is keyed.
14. Verify that the LED in the lower right side illuminates when either push to talk is keyed.
15. Verify proper Intercom system operation in the **ALL**, **ISO** and **CREW** modes (see Table 3-1).
16. Verify that the audio selector panel system does not adversely affect any other aircraft system by systematically switching the unit on and off, while monitoring the other avionics and electrical equipment on the aircraft.

2.10.1.1 Marker Checkout (7000M-S only)

1. Connect a ramp generator at the antenna end of the marker coax. With the unit under test in HI sensitivity, verify that a 160 μ V, modulated 95% with 1300 Hz, signal will illuminate the amber (M) marker light, and that marker audio is present in the headphones when the Marker Audio (M) push-button has been depressed. Select "S" for speaker to verify marker audio availability on the cabin speaker. Verify that the white (A) and blue (O) lights

PS Engineering

PMA7000M-S Series Audio Selector Panel and Intercom System
Civil Air Patrol Version Installation and Operator's Manual

will illuminate within ± 3 dB of the amber lamp, with 3000 HZ and 400 Hz applied, respectively.

2. Repeat with the unit in LOW sensitivity, with 430 μ Volts applied.
3. Connect the marker antenna and verify proper operation.

2.10.2 Receiver Sensitivity

Although the PMA7000M-S meets FAA TSO-C35d sensitivity specifications, the sensitivity of the receiver has been adjusted to meet real world requirements (150 μ V and 430 μ V, soft). This will usually eliminate the need for the avionics shop to reduce the sensitivity in the field so as to prevent early detection of the marker beacons. If your particular installation requires more or less sensitivity, see adjustment section 2.6, and figure 2-1.

2.11 Final Inspection

Verify that the wiring is bundled away from all controls and no part of the installation interferes with aircraft control operation. Move all controls through their full range while examining the installation to see that no mechanical interference exists. Verify that the cables are secured to the aircraft structure in accordance with good practices, with adequate strain relief. Ensure that there are no kinks or sharp bends in the cables and coaxial cables. Verify that the cables are not exposed to any sharp edges or rough surfaces, and that all contact points are protected from abrasion.

Complete log book entry, FAA Form 337, weight and balance computation and other documentation as required. Sample text for FAA Form 337, and instructions for continuing airworthiness can be found in Appendix F.

Return completed warranty registration application to PS Engineering.

Section III OPERATION

GENERAL INFORMATION

3.1 SCOPE

This section provides detailed operating instructions for the PS Engineering PMA7000M-S, and PMA7000S Audio Selector Panel/Intercom Systems, CAP versions. Please read it carefully before using the equipment so that you can take full advantage of its capabilities.

This section is divided into four sections covering the basic operating areas of the PMA7000M-S systems. They are Audio Selector, Transceiver Selection, Intercom, and Marker Beacon Receiver (7000M-S only).

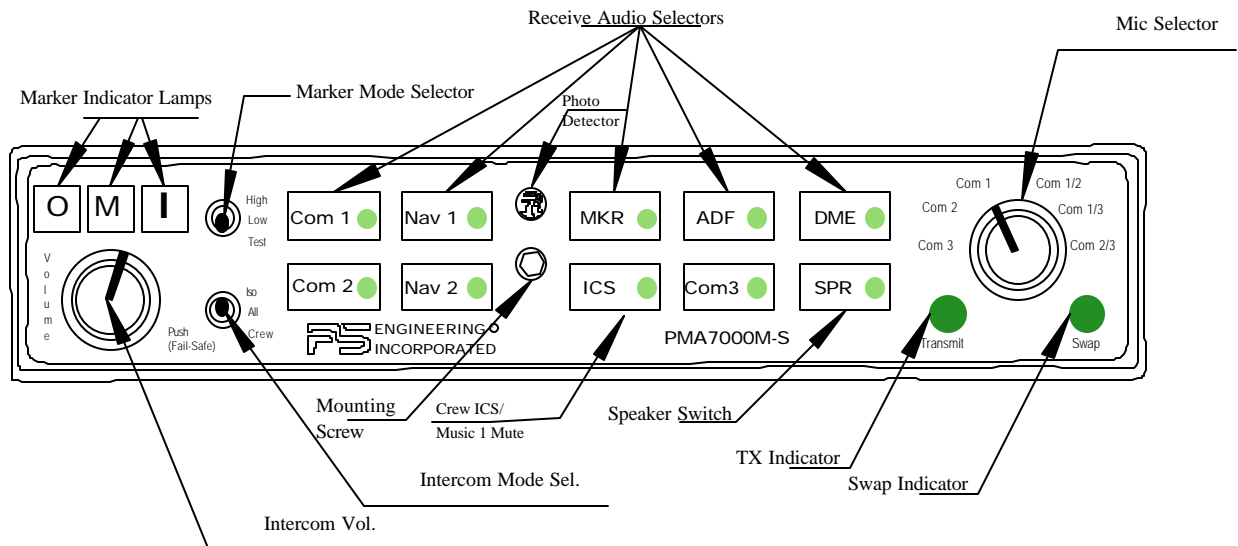

Figure 3-1 PMA7000M-S controls (CAP Version)

3.2 Audio Selector (All models)

Receiver audio is selected through two momentary and six latched, push-button, backlit switches. **Com 1** and **Com 2** are the momentary switches.

Because the rotary microphone selector switch controls what transceiver is being heard, the **Com 1** and **Com 2** push-buttons are of the momentary type and do not remain in when selected. This is also part of the "auto" function. You will always hear the audio from the transceiver that is selected for transmit by the rotary mic selector switch.

The users can identify which receivers are selected by noting which of the switch LEDs are illuminated. Push buttons labeled **Nav 1**, **Nav 2**, **COM 3**, **DME**, **MKR** (Marker), **ADF** and **SPR** (Speaker) are "latched" type switches. When one of these buttons is pressed, it will stay in

the "in" position. Press the switch again and it be in the "out" position and remove that receiver from the audio.

3.2.1 Speaker Amplifier

The "**SPR**" in the push-button section stands for speaker. This switch will place all selected audio on the cockpit speaker when this switch is selected. NOTE: The speaker amplifier is not active in the "Split Mode."

3.3 Power Switch (Fail Safe Operation)

Unit power is turned on and off by pushing the volume knob. In the OFF or "**FAIL-SAFE**" position, the pilot is connected directly to Com 1. This allows communication capability regardless of unit condition. Any time power is removed or turned OFF, the audio selector will be placed in the fail-safe mode.

The power switch also controls the audio selector panel functions, intercom, and marker beacon receiver. Unless the mic selector is in Com 3 mode, at least one of the selected audio LEDs will be on (Com 1 or Com 2).

3.4 Microphone Selector

When the mic selector switch is in the **Com 1** position, both pilot and copilot will be connected to the Com 1 transceiver. Only the person who presses their Push To Talk (PTT), will be heard over the aircraft radio. Turning the rotary switch to the **Com 2** position will place pilot and copilot on the Com 2 transceiver.

The PMA7000M-S gives priority to the pilot's PTT. If the copilot is transmitting, and the pilot presses his PTT, the pilot's microphone will be heard over the selected transmitter.

Turning the mic selector fully counterclockwise places the pilot and copilot on Com 3. Com 3 receive audio is automatically placed in the headset (and speaker if selected). Com 1 and/or Com 2 receiver audio can be selected to monitor those transceivers. The COM 3 button will illuminate, indicating that Com 3 receive audio is present.

The PMA7000M-S-Series has an automatic selector mode. Audio from the selected transceiver is automatically heard in the headsets and speaker. You can check this function by switching from COM 1 to COM 2 and watch the selected audio indicator change from COM 1 to COM 2. This ensures the pilot will *always* hear the audio from the transceiver he is using.

When switching the mic selector rotary switch from COM 1 to COM 2, while COM 2 receive audio had been selected, Com 1 receiver audio will continue to be heard. This eliminates the pilot having to switch Com 1 audio back on with the receive audio button, if desired.

When switching from COM 1 to COM 2 while Com 2 receiver audio has NOT been selected, Com 1 audio will be switched off. In essence, switching the mic selector will not effect the selection of Com audio.

3.5 Split Mode

Turning the rotary switch to COM 1/COM 2 places the PMA7000M-S into "Split Mode." This places the pilot on Com 1 and the copilot on the Com 2 transceiver. An example of this useful feature is when the pilot may want to talk to Air Traffic Control, while the copilot/observer may be speaking to the Flight Watch. Although this mode has limitations (see below) we believe you will find this to be a useful feature.

Switching to Com 1/Com 3, the pilot will be on Com 1 and the copilot will be on Com 3. In Com 2/3, the pilot is on Com 2, and the copilot on Com 3. The split mode is reversed by the swap button (see section 3.5.2).

Note:

Due to the nature of communications signals, and the size constraints in general aviation aircraft, it is probable that there will be some bleed-over in the Split mode, particularly on adjacent frequencies.

PS Engineering makes no warranty about the suitability of Split Mode in all aircraft conditions.

Note: Split Mode does not turn off other (Nav, ADF, etc.) selected audio to pilot. However, the copilot will only hear the selected communications receiver.

3.5.1 Split Mode ICS

In split mode, the pilot and copilot are usually isolated from each other on the intercom, simultaneously using their respective radios. Depressing the **ICS** button in Split Mode will activate VOX intercom between the pilot and copilot positions. This permits intercommunication when desired between the crew. Pressing the ICS button again disables this crew intercom function.

3.5.2 Swap Mode

With a yoke mounted, momentary switch, the pilot can change from the current Com transceiver to the other by depressing this switch. When "Swap Mode" is active, an annunciator in the lower right corner of the unit will illuminate, indicating that the Mic Selector switch position is no longer current. To cancel "Swap Mode," the pilot may either press the yoke mounted switch again, or turn the Mic Selector Switch to the Com that is active.

In the PMA7000MS CAP version the swap mode can be used to reverse transceiver selection in the split mode. If the mic selector is in the Com 1/2 mode, pressing the SWAP button will place the pilot on com 2 and the copilot on com 1.



Figure 3-2 CAP Version Mic Selector

Mic Selector	Normal		Swap	
	Pilot	Copilot	Pilot	Copilot
Com 1	Com 1	Com 1	Com 2	Com 2
Com 2	Com 2	Com 2	Com 1	Com 1
Com 3	Com 3	Com 3	No Swap	No Swap
Com1/2	Com 1	Com 2	Com 2	Com 1
Com 1/3	Com 1	Com 3	Com 3	Com 1
Com 2/3	Com 2	Com 3	Com 3	Com 2

Table 3-1 Transmitter Combinations

3.6 Intercom

3.6.1 IntelliVox®VOX-Squelch

No adjustment of the *IntelliVox*® squelch control is necessary. Through three individual signal processors, the ambient noise appearing in all six microphones is constantly being sampled. Non voice signals are blocked. When someone speaks, only their microphone circuit opens, their voice on the intercom.

The system is designed to block continuous tones, therefore people humming or whistling in monotone may be blocked after a few moments.

For best performance, the headset microphone must be placed within ¼ inch of your lips, preferably against them. It is also a good idea to keep the microphone out of a direct wind path. Moving your head through a vent air stream may cause the *IntelliVox*® to open momentarily. This is normal.

For optimum microphone performance, PS Engineering, Inc. recommends installation of a Microphone Muff Kit from Oregon Aero (1-800-888-6910). This will not only optimize VOX performance, but will improve the overall clarity of all your communications.

Table 3-2 Mic Muff ®Part Numbers

Manufacturer	Model	Mic Muff®Part Number
Bose	Dynamic	90010
	Electret	90015
	M87 Dynamic	90020
David Clark	H10-30	90010
	H10-20, H10-40	90015
	H10-13.4	

PS Engineering
PMA7000M-S Series Audio Selector Panel and Intercom System
Installation and Operator's Manual for Civil Air Patrol

LightSpeed	15K 20K	90015
Peltor	7003 7004	90010 90015
Pilot	11-20 11-90	90015
Sennheiser		90015
Telex	Airman 750 AIR3000	90015 90010

3.6.2 Volume Control

The volume control knob adjusts the loudness of the intercom for the pilot and copilot only. It has no effect on selected radio levels, music input levels or passengers' volume level.

Adjust the radios and intercom volume for a comfortable listening level for the pilot. Most general aviation headsets today have built-in volume controls; therefore, passenger volume can be adjusted at the headset. If desired, passenger volume level can be adjusted by a screwdriver adjustment at the top of the tray (see figure 2-1).

3.6.2.1 Mono headsets in Stereo Installation

All passenger headsets are connected in parallel. Therefore, if a monaural headset is plugged in to a PMA7000M-S Stereo installation, one channel will be shorted. Although no damage to the unit will occur, all passengers will lose one channel. PS Engineering modifies headsets to add stereo capability, using high-fidelity speakers. Contact factory for details.

3.6.3 Intercom Modes

The lower switch on the left side is a 3-position mode switch that allows the pilot to tailor the intercom function to best meet the current cockpit situation. The description of the intercom mode function is valid only when the unit is not in the "Split" mode. Then, the pilot and copilot intercom is controlled with the ICS button.

ISO: (Up Position): The pilot is isolated from the intercom and is connected only to the aircraft radio system. He will hear the aircraft radio reception (and sidetone during radio transmissions). Copilot will hear passengers' intercom and Entertainment 1, while passengers will hear copilot intercom and Entertainment 2. Neither will hear aircraft radio receptions or pilot transmissions.

ALL: (Middle Position): All parties will hear the aircraft radio and intercom. Crew will hear Entertainment 1, passengers will hear Entertainment 2. During any radio or intercom communications, the music volume automatically decreases. The music volume increases gradually back to the original level after communications have been completed.

CREW (Down Position): Pilot and copilot are connected on one intercom channel and have exclusive access to the aircraft radios. They may also listen to Entertainment 1. Passengers can continue to communicate with themselves without interrupting the Crew and also may listen to Entertainment 2.

PS Engineering

PMA7000M-S Series Audio Selector Panel and Intercom System
Installation and Operator's Manual for Civil Air Patrol

Anytime the PMA7000M-S is in either the COM 1/COM 2, COM 1/COM 3, or COM 2/3 ("Split Mode"), the pilot and copilot intercom is controlled with the ICS button. The passengers will maintain intercommunications, but never hear aircraft radios.

3.6.3.1 Entertainment Input

The audio selector panel has provisions for two separate entertainment input devices. They operate independently in the PMA7000M-S. The volume control does not affect music level.

While in the ISO (Isolate) mode, the copilot will hear Entertainment 1 while the four passengers will hear Entertainment #2. The pilot will hear Entertainment 1, at a muted level. In normal operation, whenever a person speaks, or if the aircraft radio becomes active, the music will automatically mute and then will gradually return to the original listening level when the intercom or radio conversation ceases.

When in the ALL mode, pilot and copilot will hear Entertainment 1 input while all passengers will hear the Entertainment 2 source. While in the CREW mode, pilot and copilot will hear entertainment input #1 while the passengers may listen to entertainment input #2.

It is also possible to use only one entertainment input device for both entertainment inputs. It is suggested however, that a switch (DPDT) is installed between the single entertainment device and entertainment input #1. This will allow the pilot and copilot decide if they hear entertainment while in the Crew mode.

3.6.3.2 Soft Mute and Soft Mute inhibit

The Soft Mute feature assures that the aircraft radio transmissions will not be missed due to entertainment playing. When there is radio reception or intercom conversation, the music level is dropped to a low, or background level. When the radio or intercom traffic ceases, the level gradually returns to normal.

The front panel ICS switch controls muting of entertainment source #1. Pushing this button places the ICS in "Karoake" or sing along) mode, which inhibits the soft mute feature. This allows the music to continue uninterrupted by intercom or radio traffic when cockpit workload is appropriate. Pushing the button again will release the mute inhibit function.

The passenger music, source #2, can be placed in the Karoake mode if a remote switch is installed in the aircraft. See wiring information for details.

Table 3-3 Intercom Modes

Mode	Pilot Hears	Copilot Hears	Passengers Hear	Comments
Isolate	A/C Radios Pilot Sidetone (during radio transmission) Entertainment 1 is Muted	Copilot and passenger intercom Entertainment #1	Passenger and Copilot intercom Entertainment #2	This mode allows the pilot to communicate without the others bothered by the conversations. Copilot and passengers can continue to communicate and listen to music
All	Pilot Copilot A/C Radio Passengers Entertainment #1	Copilot Pilot A/C Radio Passengers Entertainment #1	Passengers Pilot Copilot A/C Radio Entertainment #2	This mode allows all on board to hear radio reception as well as communicate on the intercom. Music and intercom is muted during intercom and radio communications
Crew	Pilot Copilot A/C Radio Entertainment #1	Copilot Pilot A/C Radio Entertainment #1	Passengers Entertainment #2	This mode allows the pilot and copilot to concentrate on flying, while the passengers can communicate amongst themselves.

3.7 P-T-T Intercom Mode

In high noise environments the PMA7000MS can be set to a push to talk intercom. A PTT enable switch and individual PTT buttons must be installed. See section 2.4.13.

3.8 Marker Beacon (PMA7000M-S)

The optional Marker Beacon Receiver uses visual and audio indicators to alert you when the aircraft passes over a 75 MHz transmitter.

The Blue lamp, labeled "O," is the Outer Marker lamp and has an associated 400 Hertz 'dash' tone. The lamp and tone will be keyed at a rate of two tones/flushes per second when the aircraft is in the range of the Outer Marker Beacon.

The Amber lamp, labeled "M," is the Middle Marker lamp and is coupled with a 1300 Hertz tone. It is keyed alternately with short 'dot' and long 'dash' bursts at 95 combinations per minute.

The White lamp, labeled "I," is the Inner marker and has a 3000 Hertz 'dot' tone. The lamp and tone will be keyed at a rate of six times per second.

The audio from the Marker Beacon Receiver can be heard by selecting the "M" push-button switch. To adjust the volume level, there is a service adjustment located on the top of the unit. See Section 2.5

PS Engineering

PMA7000M-S Series Audio Selector Panel and Intercom System
Installation and Operator's Manual for Civil Air Patrol

A three position switch is used to set the receiver sensitivity and to test the indicator lamps. Use "HIGH" sensitivity initially. This allows you to hear the outer marker beacon about a mile out. Then select the "LOW" sensitivity to give you a more accurate location of the Outer Marker. The momentary down switch position is labeled "TEST" and illuminates all three lamps simultaneously to assure the lamps are in working order.

Section IV- Warranty and Service

4.1 Warranty

In order for the factory warranty to be valid, the installations in a certified aircraft must be accomplished by an FAA- certified avionics shop and authorized PS Engineering dealer. An FAA Form 337 must also be accompanied by the warranty card for this warranty to be in effect. If the unit is being installed by in an experimental aircraft, a factory- or dealer made harness must be installed for the warranty to be valid.

PS Engineering, Inc. warrants this product to be free from defect in material and workmanship for a period of one year from the date of installation. During this one-year warranty period, PS Engineering, Inc., at its option, will send a replacement unit at our expense if the unit should be determined to be defective after consultation with a factory technician. Shipping charges to return the defective unit are the responsibility of the customer.

This warranty is not transferable. Any implied warranties expire at the expiration date of this warranty. PS Engineering SHALL NOT BE LIABLE FOR INCIDENTAL OR CONSEQUENTIAL DAMAGES. This warranty does not cover a defect that has resulted from improper or unreasonable use or maintenance as determined by us. This warranty is void if there is any attempt to disassemble this product without factory authorization. This warranty gives you specific legal rights, and you may also have other rights which may vary from state to state. Some states do not allow the exclusion of limitation of incidental or consequential damages, so the above limitation or exclusions may not apply to you.

4.2 Factory Service

The unit is covered by a one-year limited warranty. See warranty information. Call PS Engineering, Inc. at (865) 998-9900 before you return the unit. This will allow the service technician to provide any other suggestions for identifying the problem and recommend possible solutions.

After discussing the problem with the technician and you obtain a Return Authorization Number, ship product to:

PS Engineering, Inc.
Attn: Service Department
9900 Martel Rd
Lenoir City, TN 37772
Phone (865) 988-9800 FAX (865) 988-6619

Please include a detailed description of the problem and a telephone or fax number where we can contact you during business hours.

Appendix A External PTT Hook Up

Part of the installation includes the installation of PTT (Push To Talk) switches that allow the use of your aircraft radio for communications transmissions.

There are three configurations that can be used, you must select the case that best fits your installation. NOTE: Only the person who presses their PTT switch will be heard over the radio.

CASE I

The PTT is built into the pilot and copilot yokes

Simply install the plugs from the headset into the aircraft headphone jacks. Then use the yoke mounted PTT to transmit. No other action is required.

CASE II

Built in PTT only on the pilot side only

This configuration requires a modified external PTT switch plugged into the copilot's mic jack. (See Details Below) When the copilot's PTT is depressed, this activates an internal relay that switches the mic audio to the aircraft radio from the pilot to the copilot.

Case III

No built in PTT switch at all.

Two built-in PTT must be installed, or two external, modified PTT switches will be required for both the pilot and copilot. Modifications to the PTT are required. (See details below)

Push To Talk Modifications

When received from the manufacturer, an after-market PTT switch opens the mic audio path to the "ring" connection of the PTT mic plug until the button is pressed. When the PTT is between the intercom and the headset, the intercom function will not work unless the PTT switch is depressed. A simple modification can be performed to allow proper intercom operation. NOTE: This mod does not alter normal operation.

Below are some examples of typical modifications. Contact PS Engineering or the PTT manufacturer for more details if necessary.

Procedures For David Clark PTT

Unscrew the round black plastic cover from the jack.
Connect the joined black wires to the red wire.
Replace the round black plastic cover.

Procedures for Telex PT-200

Unscrew the round black plastic cover from the jack.
Cut the red wire in the middle of the wire.
Strip both ends of the insulation.
Solder the two ends to the ground lug to the PTT jack.
Replace the round black plastic cover.

Procedures for Telex PT-300

Unscrew the round black plastic cover from the plug jack.
Remove the heat shrink material from the joined black wires.
Solder these two wires to the lug that has a white wire already soldered to it.
Replace the round black plastic cover

Appendix B Installation Drawing

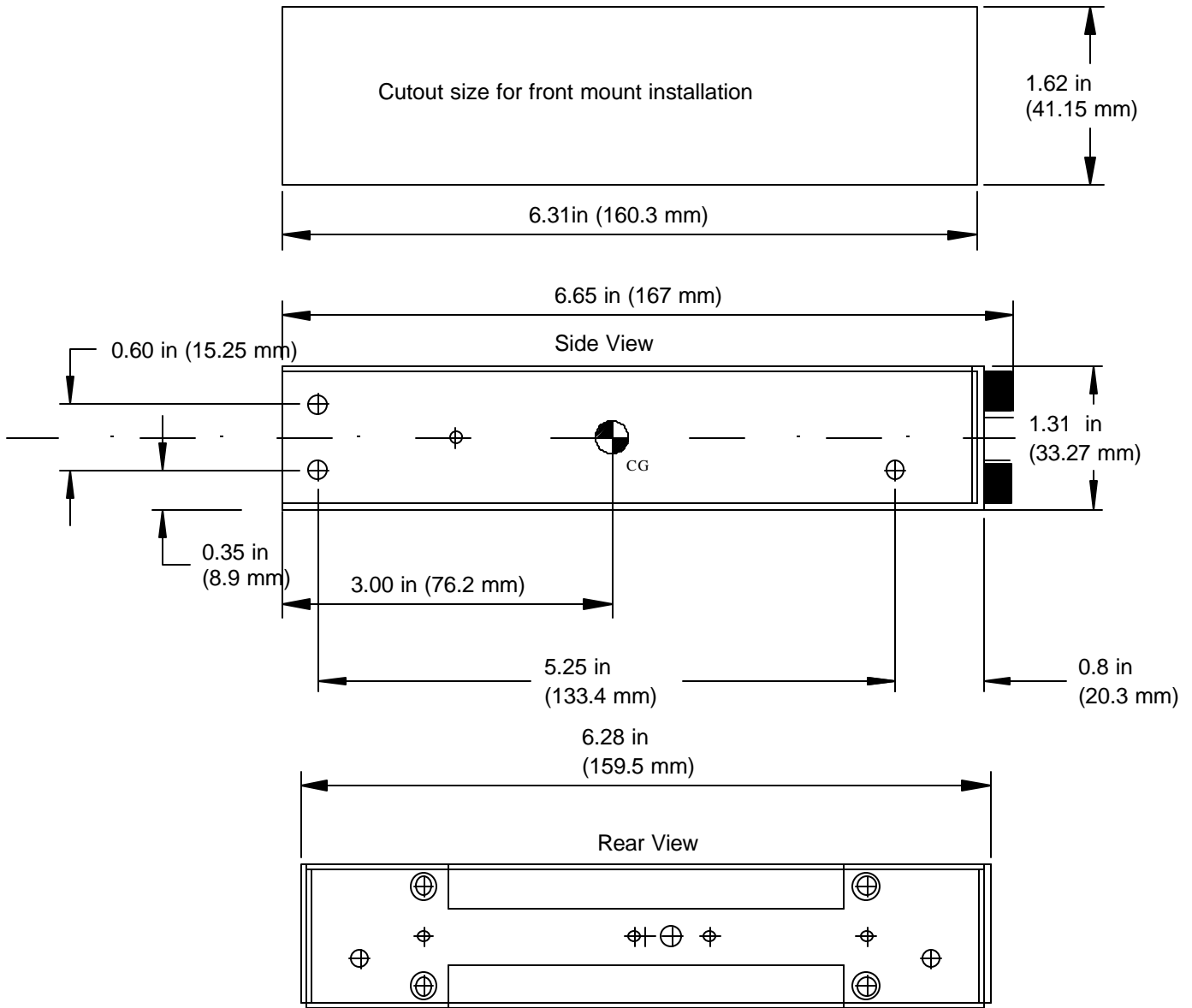

Weight: 1.5 lb with tray and connectors (.68 kg)

Connector viewed from the rear

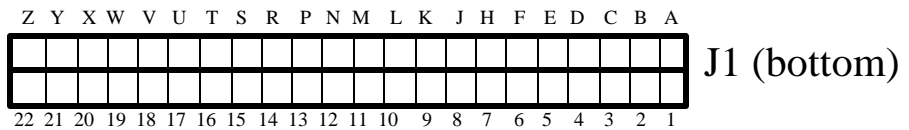
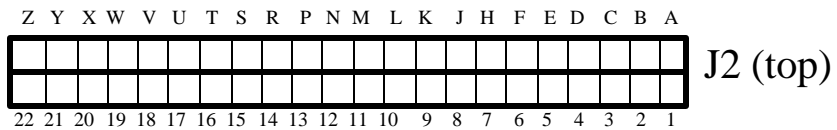

Appendix C Bottom Connector Interconnect

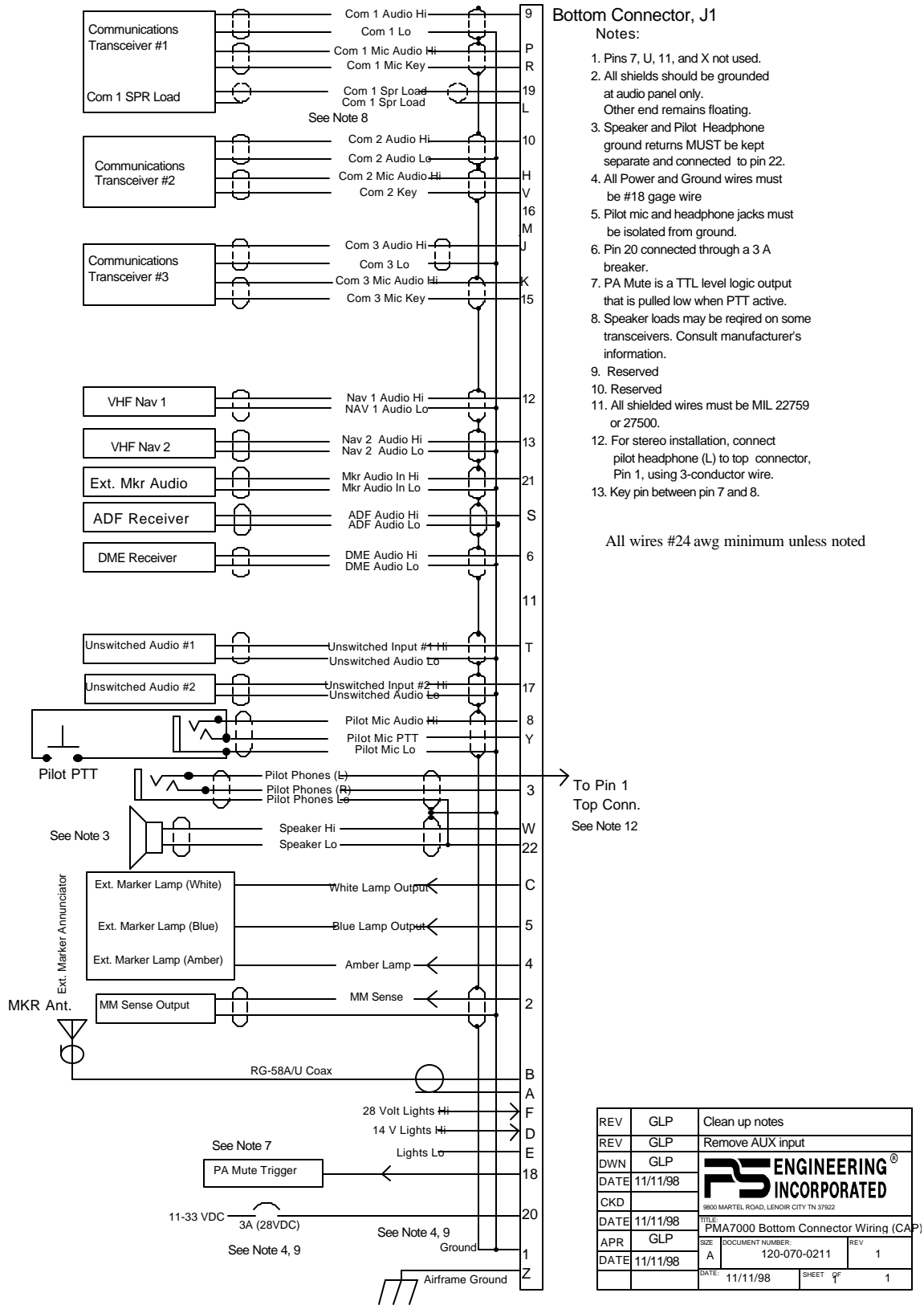

REV	GLP	Clean up notes
REV	GLP	Remove AUX input
DWN	GLP	
DATE	11/11/98	
CKD		
DATE	11/11/98	
APR	GLP	
DATE	11/11/98	
TITLE		PMA7000 Bottom Connector Wiring (CAP)
SIZE	DOCUMENT NUMBER	REV
A	120-070-0211	1
DATE	11/11/98	SHEET 9F 1

Appendix D Top Connector Interconnect

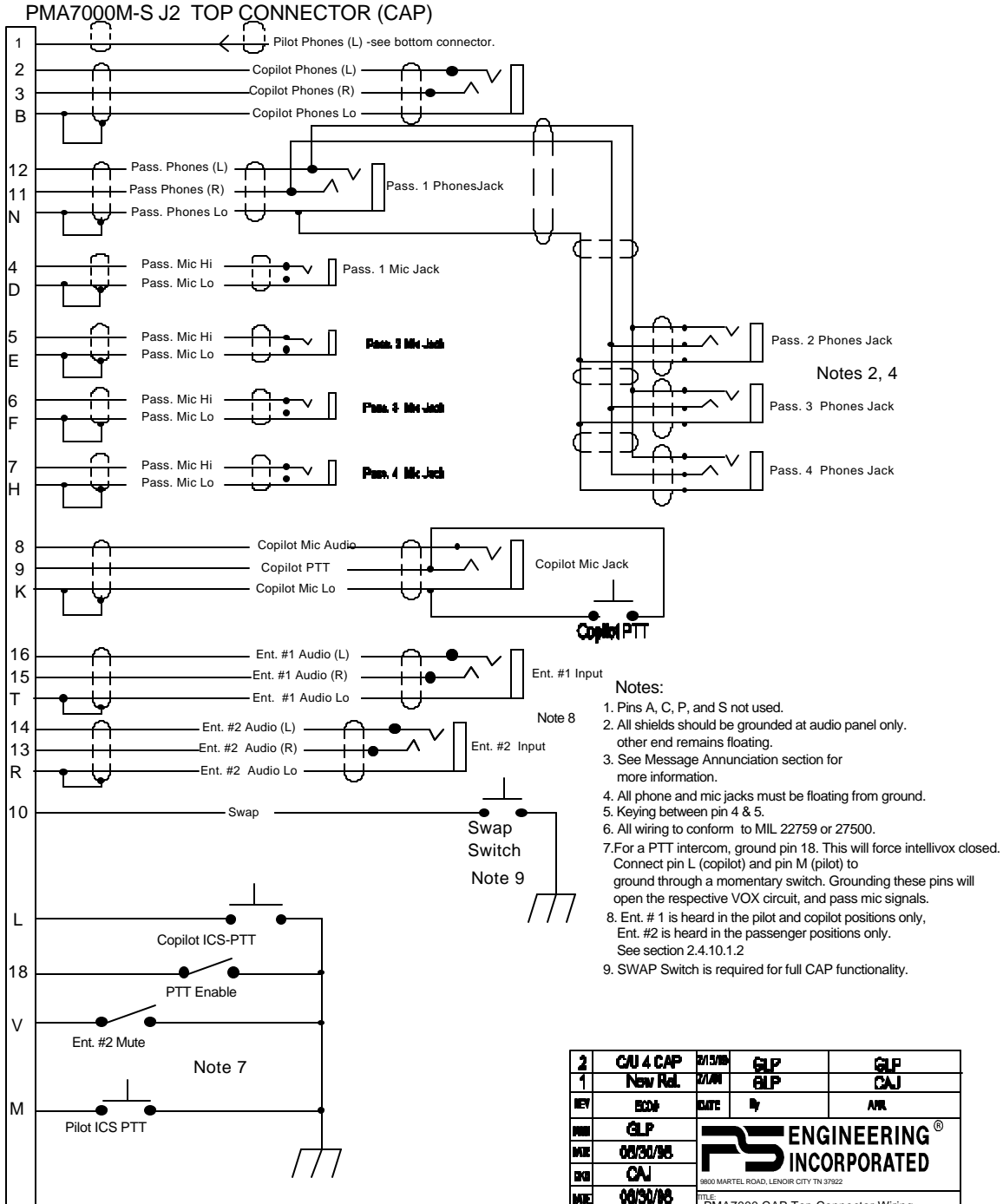

2	CAU 4 CAP	Z/13/98	GLP	GLP
1	New Rel.	Z/13/98	GLP	CAJ
REV	ED#	DATE	BY	APP
REV	GLP			
REV	08/30/98			
REV	CAJ			
REV	08/30/98			
APP	GLP	DOCUMENT NUMBER:	120-070-0402	REV 2
REV	07/01/98	DATE:	07/01/98	SHEET of 1

PS ENGINEERING INCORPORATED
9800 MARTEL ROAD, LENOIR CITY TN 37922

TITLE: PMA7000 CAP Top Connector Wiring

Appendix E Supplemental Wiring per Civil Air Patrol Headquarters.

Purpose:

The purpose of this document is to provide interconnect information to add a transmit position (observer) to share the COM 3 transceiver if necessary.

Applicability

This applies only to PMA7000MS-CAP versions.

Components required

K1 and K2- Potter & Brumfield KHS-14D11-24
Diodes- 1N4004 (or Equiv.) (3 ea.)
Switch- SPDT Momentary, Center off
Mil-Spec = 11TW1-7
Industrial = 11TS15-7
Standard = 7105SYZQE

Limitations

All wires must be Mil-Spec. Use 2-, 3- and 4- conductor wire with shield as indicated. Use insulating washers on all jacks to prevent ground loops. Connect shields at unit only.

This drawing is for reference only. PS Engineering, Inc. makes no guarantee that this interconnect will work in all cases.

Operational notes

1. Pass 1 can only transmit on CAP radio.
2. Pilot and copilot can still hear CAP radio
3. Pilot and copilot can hear passenger transmit.
4. Pilot and copilot positions still have use of all 3 radios except when the Pass 1 is in ICS PTT.
5. Pass 1 push to talk puts him on CAP com only.
6. The crew can hear, but cannot transmit on COM 3 while the PASS 1 has radio keyed.
7. When the Pass 1 uses the ICS PTT, he overrides the copilot on the intercom.
 - a. When the PTT ICS is activated,
 - b. the copilot cannot transmit

PS Engineering

PMA7000M-S Series Audio Selector Panel and Intercom System
 Installation and Operator's Manual for Civil Air Patrol

- c. This prevents the passenger's voice from going out instead of the copilot's.
- d. If pass 1 does not push the ICS PTT switch, he will be heard on the passenger intercom, but NOT in crew intercom in CREW or Split modes.

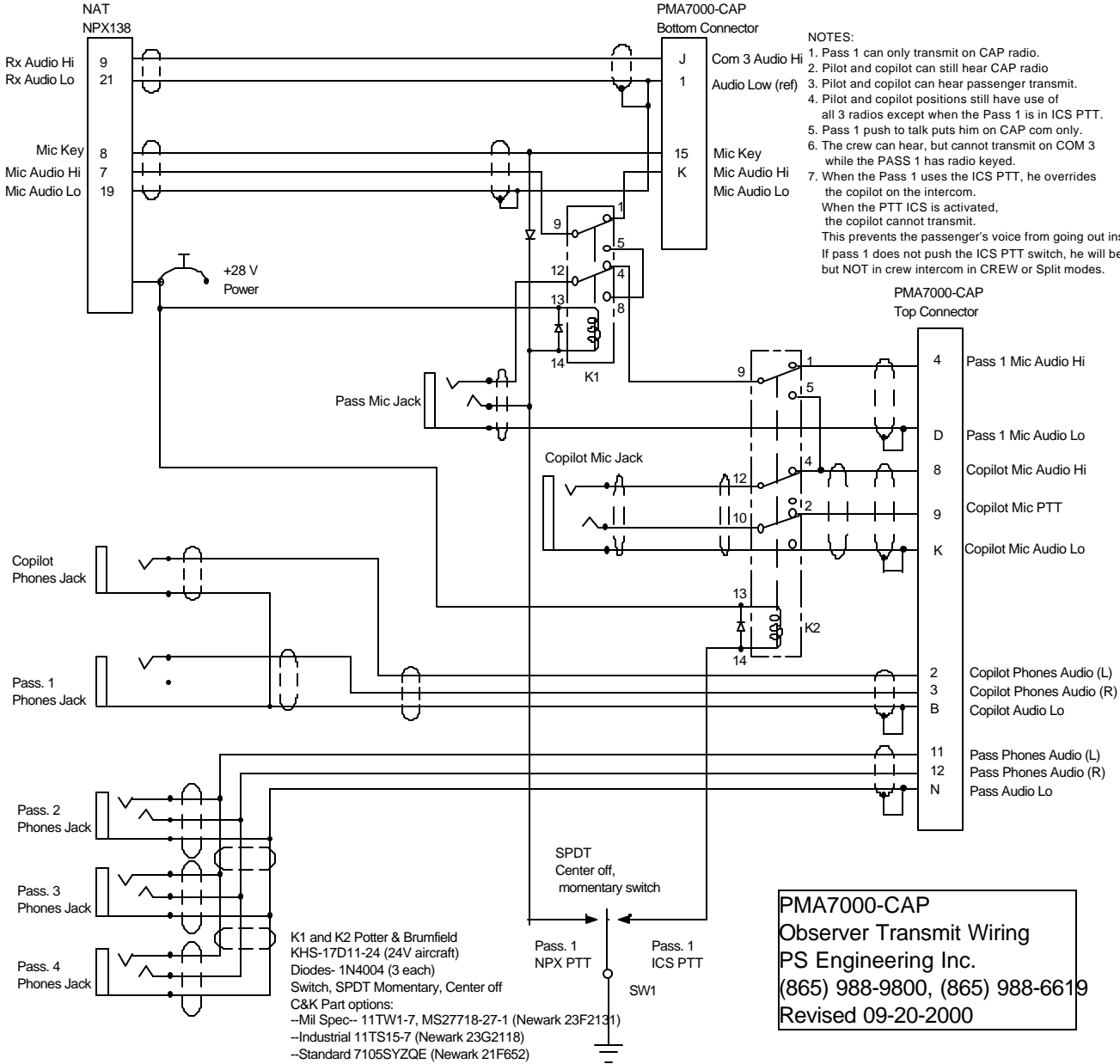

Appendix F - Instructions for FAA Form 337 and continuing airworthiness Instructions for FAA Form 337, Audio Panels

One method of airworthiness approval is through an FAA Form 337, *Major Repair and Alteration (Airframe, Powerplant, Propeller, or Appliance)* In the case of the PMA7000M-S, you may use the following text as a guide.

Installed audio selector and 6-place intercom, PS Engineering PMA7000M-S, part number 7000 (X) in (location) at station _____. Installed per AC43.13-2, Chapter 2, paragraph 23 (Instrument Panel Mounting). Installed per PS Engineering *Installation Operators Manual* p/n 200-072-(XXXX), revision (), dated ().

This unit is FAA-Approved under TSO C50c for audio amplifiers, TSO C35d for Marker Beacon Receivers, and meets appropriate environmental qualifications outlined in RTCA DO-160C as appropriate or this aircraft.

Interface to existing aircraft radios in accordance with installation manual and in compliance with practices listed in AC43.13-2, Chapter 2. All wires are Mil-Spec 22759 or 27500. Connection to aircraft dimmer bus is _____. Power is supplied to the unit through a 3A circuit breaker (type and part number), and total electrical load does not exceed _____% of the electrical system capacity with the PMA7000M-S added.

Aircraft equipment list, weights and balance amended. Compass compensation checked. A copy of the operation instructions, contained in PS Engineering document 200-072-(), revision (), dated (), is placed in the aircraft records. All work accomplished listed on Work Order _____.

Instructions for Continuing Airworthiness, Audio Panels

Sample ICA Checklist for PS Engineering Audio Panels:

Section	Item	Information
1	Introduction	Installation of audio control panel with integrated marker beacon receiver and intercommunications system.
2	Description	Installation as described in manufacturer's installation manual referenced on FAA Form 337, including interface with other avionics audio as required.
3	Controls	See installation and operator's guide referenced on FAA Form 337.
4	Servicing	None Required
5	Maintenance Instructions	On Condition, no special instructions
6	Troubleshooting	In the event of a unit problem, place the unit into "off," "fail-safe" and/or "emergency" mode. This allows pilot communications using COM 1. Follow checkout instructions in the installation manual referenced on the FAA Form 337. For a specific unit fault, contact the manufacturer at (865) 988-9800 for special instructions.
7	Removal and replacement information	<u>Removal:</u> Using a 3/32" Allen-head wrench, carefully unscrew the locking screw located in the center of the unit. While turning the wrench CCW, gently pull on the EDGES of the bezel until the unit is free from the mounting tray. <u>Installation:</u> Engage the locking screw at the back. Turn the locking screw CW, while applying slight pressure to the edges of the bezel. Do not over tighten!
8	Diagrams	Not applicable
9	Special Inspection Requirements	Not Applicable
10	Protective Treatments	Not Applicable
11	Structural Data	Not Applicable
12	Special Tools	None
13	Not Applicable	Not Applicable
14	Recommended Overhaul Periods	None
15	Airworthiness Limitations	Not Applicable
16	Revision	To be determined by installer

Appendix G RTCA DO160C Environmental Qualification Form

Audio Selector Panel/Intercom/Maker Beacon Receiver

Part Number: 7000; 7000M; 7000S; 7000M-S

FAA TSO Number: C50c, C35b Class A

Manufacturer: PS Engineering Incorporated 9900 Martel Road Lenoir City TN 37772

Conditions	Section	Conducted Tests
Temperature and Altitude	4.0	Equipment tested to CAT A1 & D1
Low Temperature	4.5.1	-20° C Storage, -15°C Low Operating
High Temperature	4.5.2	+85°C Storage, +70°C High Operating
In-flight Loss of Cooling	4.5.4	Not Applicable, no cooling required
Altitude	4.6.1	50,000' unpressurized
Decompression	4.6.2	Not Applicable
Overpressure	4.6.3	Not Applicable
Temperature variation	5.2	Equipment tested to Category C
Humidity	6.0	Equipment tested to Category A
Shock	7.0	Equipment tested to Operational test only
Operational	7.2	Equipment tested to Operational test only
Crash Safety	7.3	Equipment tested to Operational test only
Vibration	8.0	Equipment tested to Category M & N
Explosion	9.0	Category X, not tested
Waterproofness	10.0	Category X, not tested
Fluids Susceptibility	11.0	Category X, not tested
Sand and Dust	12.0	Category X, not tested
Fungus	13.0	Category X, not tested
Salt Spray	14.0	Category X, not tested
Magnetic Effect	15.0	Equipment tested to Category Z
Power input	16.0	Equipment tested to Category B
Voltage Spike	17.0	Equipment tested to Category B
Audio Frequency Susceptibility	18.0	Equipment tested to Category B
Induced Frequency Susceptibility	19.0	Equipment tested to Category B
Radio Frequency Susceptibility	20.0	Equipment tested to Category T
Radio Frequency Emission	21.0	Equipment tested to Category B
Lightning Induced Transient Susceptibility	22.0	Equipment tested to Category K
Lightning Direct Effects	23.0	Category X, not tested
Icing	24.0	Category X, not tested