

Aircrew & Flightline Tasks



11 April 2005

Developed as part of the
National Emergency Services Curriculum Project

NATIONAL EMERGENCY SERVICES CURRICULUM
AIRCREW & FLIGHTLINE TASKS

The following tasks are included in this task guide.

Task # Task Title

Command Tasks

None

Operations Tasks

- O-0204 LOCATE A POINT ON A MAP USING LATITUDE AND LONGITUDE
- O-0205 LOCATE A POINT ON A MAP USING THE CAP GRID SYSTEM
- O-2000 OPERATE THE AIRCRAFT FM RADIO
- O-2001 OPERATE THE AIRCRAFT AUDIO PANEL
- O-2002 DEMONSTRATE OPERATION OF THE AIRCRAFT RADIOS
- O-2003 GRID SECTIONAL CHARTS
- O-2004 USE A POD TABLE
- O-2005 OPERATE THE AIRCRAFT DIRECTION FINDER
- O-2006 PERFORM ELT SEARCHES
- O-2007 LOCATE AND SILENCE AN ELT ON THE GROUND
- O-2008 COMPLETE A MISSION SORTIE
- O-2009 DEMONSTRATE AIR/GROUND TEAM COORDINATION TECHNIQUES
- O-2010 USE IN-FLIGHT SERVICES
- O-2011 OPERATE THE VOR AND DME
- O-2012 OPERATE THE GLOBAL POSITIONING SYSTEM
- O-2013 PLOT A ROUTE ON A SECTIONAL CHART
- O-2015 DEMONSTRATE GROUND OPERATIONS AND SAFETY
- O-2016 DEMONSTRATE SAFETY WHILE TAXIING
- O-2017 DISCUSS POST-CRASH ACTIONS
- O-2018 OPERATE THE AIRCRAFT COMMUNICATIONS EQUIPMENT
- O-2019 USE PROPER NUMBER AND CHARACTER PRONUNCIATION
- O-2020 USE PROWORDS
- O-2021 INTERPRET EMERGENCY SIGNALS AND DEMONSTRATE AIR/GROUND TEAM COORDINATION
- O-2022 DEMONSTRATE SCANNING PATTERNS AND LOCATE TARGETS
- O-2023 DEMONSTRATE TECHNIQUES TO REDUCE FATIGUE
- O-2024 USE SECTIONAL CHARTS
- O-2025 TRACK AND RECORD POSITION ON SECTIONALS AND MAPS
- O-2101 DESCRIBE HOW ELTS ARE DETECTED
- O-2102 DEMONSTRATE PLANNING AND FLYING A ROUTE SEARCH
- O-2103 DEMONSTRATE PLANNING AND FLYING A PARALLEL TRACK SEARCH
- O-2104 DEMONSTRATE PLANNING AND FLYING A CREEPING LINE SEARCH
- O-2105 DEMONSTRATE PLANNING AND FLYING A POINT BASED SEARCH
- O-2106 PLAN AND COMMAND A CAP FLIGHT
- O-2107 PREPARE FOR A TRIP TO A REMOTE MISSION BASE
- O-2108 ASSIST IN ELT SEARCHES
- O-2109 ASSIST IN PLANNING AND PERFORMING A ROUTE SEARCH
- O-2110 ASSIST IN PLANNING AND PERFORMING A PARALLEL TRACK SEARCH
- O-2112 ASSIST IN PLANNING AND PERFORMING A POINT-BASED SEARCH
- O-2115 ASSIST IN PLANNING AND PERFORMING A CREEPING LINE SEARCH

Task #	Task Title
O-3001	DISCUSS FLIGHT LINE MARSHALLER'S RESPONSIBILITIES
O-3002	STATE THE FIVE FLIGHT LINE SAFETY PRECAUTIONS
O-3003	IDENTIFY REQUIREMENTS FOR VEHICLES ON THE FLIGHT LINE
O-3004	DISCUSS FLIGHT LINE SECURITY
O-3005	DISCUSS FLIGHT LINE HAZARDS
O-3006	MARSHALL AN AIRCRAFT
O-3007	BE A WING WALKER
O-3008	PERFORM AIRCRAFT STARTUP PROCEDURES
O-3009	PERFORM AIRCRAFT TAXI PROCEDURES
O-3010	PERFORM AIRCRAFT SHUTDOWN AND CHOCKING PROCEDURES
O-3011	TIE DOWN AN AIRCRAFT
O-3012	DEMONSTRATE PROPER GROUND SAFETY OBSERVER TECHNIQUES
O-3013	DEMONSTRATE THE ABILITY TO FUEL AN AIRCRAFT
O-3014	DEMONSTRATE KNOWLEDGE OF FLIGHTLINE SECURITY
O-3101	DISCUSS FLIGHTLINE SUPERVISOR RESPONSIBILITIES
O-3102	DISCUSS HOW TO SET UP A FLIGHTLINE
O-3103	DISCUSS FLIGHTLINE ORGANIZATION
O-3104	COORDINATE ACTIVITIES WITH LOCAL FBO
O-3105	COORDINATE ACTIVITIES WITH AIRPORT ADMINISTRATION AND SECURITY
O-3106	COORDINATE ACTIVITIES WITH LOCAL FIRE DEPARTMENT
O-3107	COORDINATE ACTIVITIES WITH LOCAL HOSPITAL AND OR EMT OPERATORS
O-3108	SURVEY AIRPORT FOR THE BEST PARKING AREAS AND TAXI ROUTES
O-3109	SURVEY AIRPORT FOR HAZARDS AND EMERGENCY EQUIPMENT
O-3110	SUPERVISE FLIGHTLINE MARSHALLERS
O-3111	BRIEF FLIGHTLINE MARSHALLERS AND TRAINEES
O-3112	TOW AND PARK AIRCRAFT
O-3113	REFUEL AN AIRCRAFT
O-3114	KEEP TRACK OF AIRCRAFT REFUELING
O-3115	DISCUSS HELICOPTER OPERATIONS

Planning Tasks

P-0101	KEEP A LOG
P-2001	DISCUSS MISSION PILOT DUTIES AND RESPONSIBILITIES
P-2002	DISCUSS GENERAL CAP-RELATED SAFETY REQUIREMENTS AND ISSUES
P-2003	DISCUSS TYPES OF FLIGHTS PERFORMED BY CAP AIRCREWS
P-2004	DISCUSS SECURITY CONCERNS AND PROCEDURES
P-2005	DISCUSS MISSION PILOT RESPONSIBILITIES DURING A MISSION
P-2007	DISCUSS MISSION OBSERVER DUTIES AND RESPONSIBILITIES
P-2008	DISCUSS THE DANGERS OF ICING
P-2009	DISCUSS THE DANGERS OF REDUCED VISIBILITY CONDITIONS
P-2010	DISCUSS THE DANGERS OF WIND AND THUNDERSTORMS
P-2011	DISCUSS THE EFFECTS OF DENSITY ALTITUDE ON AIRCRAFT PERFORMANCE
P-2012	IDENTIFY CONTROLLED AND SPECIAL USE AIRSPACES ON A SECTIONAL
P-2013	DISCUSS MISSION SCANNER DUTIES AND RESPONSIBILITIES
P-2014	DISCUSS CAP LIABILITY COVERAGE AND MISHAP REPORTING
P-2015	ENTER DATA INTO CAP FORMS
P-2016	IDENTIFY AND DISCUSS MAJOR AIRCRAFT CONTROLS
P-2017	IDENTIFY AND DISCUSS MAJOR AIRCRAFT INSTRUMENTS
P-2018	DISCUSS AIRCRAFT WEIGHT AND BALANCE

Task # Task Title

- P-2019 IDENTIFY ITEMS CHECKED DURING AN AIRCRAFT PRE-FLIGHT INSPECTION
- P-2020 DISCUSS THE DANGER OF WAKE TURBULENCE
- P-2021 DISCUSS HOW ATMOSPHERIC AND LIGHTING CONDITIONS AFFECT SCANNING EFFECTIVENESS
- P-2022 IDENTIFY VISUAL CLUES AND WRECKAGE PATTERNS
- P-2023 DISCUSS HOW REDUCED VISIBILITY AND TURBULENCE AFFECT SEARCH OPERATIONS
- P-2024 DISCUSS STRATEGIES TO COMBAT HIGH ALTITUDE EFFECTS
- P-2025 DISCUSS COMMON SEARCH TERMS
- P-2026 IDENTIFY WHAT TO LOOK FOR AND RECORD DURING DAMAGE ASSESSMENT MISSIONS
- P-2027 DESCRIBE CAP SEARCH PATTERNS
- P-2028 DISCUSS CREW RESOURCE MANAGEMENT
- P-2119 DEMONSTRATE HOW TO COMPLETE A CAP AIRCRAFT INSPECTION

Logistics Tasks

- L-0001 BASIC COMMUNICATIONS PROCEDURES FOR ES OPERATIONS

Finance/Administrative Tasks

None

LOCATE A POINT ON A MAP USING LATITUDE AND LONGITUDE

CONDITIONS

Given an aeronautical chart, road map, or topographical map with latitude and longitude lines. You are away from mission base, mounted or dismounted, and must locate your location on map in order to report your location to mission base, an aircraft or another ground element using latitude and longitude. Or, you are coordinating with another search element (ground or air) who has told you his location using the latitude and longitude. You want to plot this point on your map.

OBJECTIVES

Within 1 minute, the team member announces the correct latitude and longitude of the marked point (using the smallest gradations of latitude and longitude printed on the map), using correct terminology, and, within 1 minute, can plot a point on the map given the latitude and longitude orally.

TRAINING AND EVALUATION

Training Outline

1. Latitude and longitude are the objective position measurements used on aeronautical charts. Many road maps and topographical maps also are gridded using this system.
 - a. Lines of longitude run north-south on the map. Lines of latitude run east-west.
 - b. Both latitude and longitude are measured in degrees, minutes and seconds. One minute is 1/60th of a degree, and one second is 1/60th of a minute. In the continental US, latitude numbers are read from south to north (bottom to top), and longitude numbers are read from east to west (right to left)
 - c. Each line of latitude is labeled as either North (if it is above the equator) or South (if it is below the equator). Each line of longitude is labeled as East (if it is east of a longitude line called the Prime Meridian) or West (if it is west of the Prime Meridian)
 - d. To read a lat-long coordinates the symbol “°” means degrees, an apostrophe (“ ‘ ”) means minutes, and a double apostrophe (“ “ ”) means seconds. Always read the latitude before the longitude.
 - e. Example: 32° 33’ 44” N, 45° 12’ 52” E means “32 degrees, 33 minutes, and 44 seconds North Latitude, 45 degrees 12 minutes and 52 seconds East Longitude”
 - f. On larger scale maps, or when pinpoint accuracy is not required, seconds are not used. For example, 45° 12’ N, 22° 36 W is read as “45 degrees, 12 minutes North Latitude, 22 degrees 36 minutes West Longitude.”
2. To find the lat-long designation of a known point on the map
 - a. Find the latitude:
 - 1) Find the numbers of the latitude degree lines to the immediate north and south of the point. Write down the lower of the two. (For example, if the point is between 45° and 46° North latitude, write down

“45°“. Also write down if that latitude line is labeled as “North” or “South” (above the equator it will always be “North”).

2) From latitude line chosen above, count up the number of minutes that the point is from the line using the tick marks on the edge of the map (or in the grids if the map is gridded) until you reach the last minute marking before your point. Write down the number of minutes.

3) From the last minute mark, count up the number of seconds to your point (if the map is of a large scale, such as an aviation chart, it will not have marks for seconds. Either stop with the minute measurement, or estimate seconds). Write down the number of seconds.

b. Find the longitude.

1) Find the numbers of the longitude degree lines to the immediate east and west of the point. Write down the lower of the two. (For example, if the point is between 22° and 23° West longitude, write down “22° “). Also write down if that longitude line is labeled as “East” or “West” (in the western hemisphere it will always be “West”).

2) From longitude line chosen above, count left the number of minutes that the point is from the line using the tick marks on the edge of the map (or in the grids if the map is gridded) until you reach the last minute marking before your point. Write down the number of minutes.

3) From the last minute mark, count left the number of seconds to your point (if the map is of a large scale, such as an aviation chart, it will not have marks for seconds. Either stop with the minute measurement, or estimate seconds). Write down the number of seconds.

c. NOTE: If the map is not marked with minutes or seconds, you will have to estimate. Remember, there are 60 minutes in a degree and 60 seconds in a minute. So, if the point is halfway between two degrees, it is at the 30 minute point. If it is one quarter the distance from one degree to another, it is at the 15 minute point. Use the same logic to determine seconds if the map is only graduated in degrees and minutes.

c. Make sure the lat-long coordinate you have written down is in the format Degrees°, Minutes’, Seconds” (North or South) Latitude, Degrees°, Minutes’, Seconds” (East or West) Longitude,

3. To plot a point given the lat-long coordinate:

a. Find the correct latitude line and count up the correct number of minutes and seconds (below the equator you would count down, not up).

b. Find the correct longitude line and count left the correct number of minutes and seconds (in the eastern hemisphere you would count right, not left).

c. Mark the point.

Additional Information

More detailed information on this topic is available in the Ground Team Member and Leader Reference Text and Mission Aircrew Reference Text.

Evaluation Preparation

Setup: Mark a point on a map or chart gridded with latitude and longitude, and give the map to the student. . Tell him whether or not he must report seconds, or just degrees and minutes (depends on the scale of the map). Pick a different grid location from the point and write down the latitude and longitude coordinates. Ensure you have a timer. Because this task is timed, it is necessary to make sure that the student and work area is prepared for testing. The map should be open and complete. If copies of maps are used, they should include all references normally available on the full map to take the exam.

Brief Student: Ask the student if he is prepared. Tell the student to tell you the latitude and longitude of the point. Then orally give him the latitude and longitude you wrote down and tell him to show you where that point is on the map.

Evaluation

Performance Measures

Results

Determining the grid of a known point. The student:

- | | | |
|--|---|---|
| 1. Announces the correct latitude degrees, minutes and seconds within tolerance (see below) | P | F |
| 2. Announces the correct latitude designation “North” or South” | P | F |
| 3. Announces the correct longitude degrees, minutes and seconds within tolerance (see below) | P | F |
| 4. Announces the correct longitude designation “East” or “West” | P | F |
| 5. Performs the above steps within 1 minute of time | P | F |

NOTE: The minimum accuracy for this task is to be within 30 seconds of the correct answer for a map graduated in minutes. If the map is large enough scale to be graduated in seconds, then the needed accuracy should be increased. For dismounted work, a ground team with proper maps should be able to plot positions within 10 seconds.

The individual determines the location of a designated grid:

- | | | |
|---|---|---|
| 6. Plots a point on the map within 1 minute using the correct latitude and longitude degrees, minutes and seconds within tolerance (see accuracy note above). | P | F |
|---|---|---|

Student must receive a pass on all performance measures to qualify in this task. If the individual fails any measure, show what was done wrong and how to do it correctly.

LOCATE A POINT ON A MAP USING THE CAP GRID SYSTEM**CONDITIONS**

Given an aeronautical chart, road map, or topographical map gridded with the CAP grid system. You are away from mission base, mounted or dismounted, and must plot your location on a CAP gridded map in order to report it, an aircraft or another ground element. Or, you are coordinating with another search element (ground or air) who has told you his location using the CAP grid system. You want to plot this point on your map.

OBJECTIVES

Within 1 minute, the team member announces the CAP grid and sub-grid that the point is located in, using correct terminology, and can plot a point on the map given the CAP grid coordinates orally.

TRAINING AND EVALUATION**Training Outline**

1. The CAP grid system is designed for use on aeronautical charts, but can be adapted to any map with latitude/longitude markings around the edge.
2. A grid is a 15 minute latitude by 15 minute longitude box. This is done by dividing the 30 minute by 30 minute boxes already on the aeronautical chart into fourths. Each grid is identified with a number. (For example "I am located in Grid 54").
3. To locate a position more precisely, mentally divide each grid into four quadrants. The Northwest quadrant is "A", the Northeast is "B", the Southwest is "C", and the Southeast is "D". Say the quadrant letter after the grid number (for example, "I am in grid 54 B").

54	55
82	<div style="display: flex; flex-direction: column; align-items: center;"> <div style="display: flex; justify-content: space-around; width: 100%;"> 83 </div> <div style="display: flex; justify-content: space-around; width: 100%;"> A B </div> <div style="display: flex; justify-content: space-around; width: 100%;"> C D </div> </div>

Example of CAP grids (54,55,82 and 83) and lettered quadrants (83A, 83B, 83C, and 83D)

4. To find the grid designation of a known point on the map
 - a. Find the grid number the point is in.

b. Determine which quadrant of the grid the point is in (A, B, C, or D)

5. To plot a point given a grid number and quadrant letter:

a. Find the appropriate grid on the map (the grid numbers increase as you look left to right and top to bottom on the map).

b. Mark the point in the appropriate lettered quadrant of that grid.

Additional Information

More detailed information on this topic is available in the Ground Team Member and Leader Reference Text and the Mission Aircrew Reference Text.

Evaluation Preparation

Setup: Mark a point on a CAP gridded map or chart and give the map to the student. Pick a different grid location from the point and write down the grid and quadrant. Ensure you have a timer.

Brief Student: Tell the student to tell you the CAP grid and quadrant designation of the point. Then orally give him the grid and quadrant of the point you wrote down and tell him to show you where that point is on the map.

Evaluation

Performance Measures

Results

The individual determines the grid of a known point:

1. Announces the correct grid number and quadrant within 1 minute

P F

The individual determines the location of a designated grid:

2. Finds the correct numbered grid and quadrant within 1 minute

P F

Student must receive a pass on all performance measures to qualify in this task. If the individual fails any measure, show what was done wrong and how to do it correctly.

O-2000
OPERATE THE AIRCRAFT FM RADIO

CONDITIONS

You are a Mission Pilot trainee and must demonstrate how to operate the CAP VHF FM radio.

OBJECTIVES

Demonstrate and discuss the use of the CAP VHF FM radio, and discuss CAP-specific communications.

TRAINING AND EVALUATION

Training Outline

1. As a Mission Pilot trainee, knowing how to set up and use the VHF FM radio is essential. This radio enables you to communicate effectively with mission base and ground units. Observers and scanners will normally operate the FM radio.

2. *Aviation communications radios.* Some aviation frequencies are designed for air-to-air communications and may be used by CAP aircraft (or any other general aviation aircraft). 123.1 MHz is the official SAR frequency. 122.75 and 122.85 MHz are air-to-air communications frequencies (and for use by private airports not open to the general public). 122.90 MHz is the Multicom frequency; it *can* be used for search and rescue, *but* is also used for other activities of a temporary, seasonal or emergency nature (note, however, that it is also used by airports without a tower, FSS or UNICOM). Follow your communications plan, if applicable, and don't abuse these frequencies. Look at the sectional to see if 122.90 MHz is used by nearby airports, and always listen before you transmit.

3. *Callsigns.* CAP aircraft have been authorized to use FAA callsigns, just like the major airlines and commuter air carriers. This helps differentiate us from civil aircraft, air taxis, and many other commercial aircraft. Our FAA authorized callsign is "Cap Flight XX XX," where the numbers are those assigned to each Wing's aircraft. *The numbers are stated in 'group' form.* For example, the C172 assigned to Amarillo, Texas is numbered 4239, where 42 is the prefix identifying it as a Texas Wing aircraft. The callsign is thus pronounced "Cap Flight Forty-Two Thirty-Nine." It is important to use the group form of pronunciation because FAA air traffic controllers expect it of us. [NOTE: There are a few exceptions to this rule, such as when you perform certain counter drug operations. In these rare cases you may be directed to use the aircraft 'N' number as your callsign.]

[NOTE: CAP aircraft should use the word "Rescue" in their callsign when priority handling is *critical*. From the example above, this would be "Cap Flight Forty-Two Thirty-Nine Rescue." DO NOT abuse the use of this code; it should only be used when you are on a critical mission *and* you need priority handling. NEVER use the word "rescue" during training or drills.]

4. *CAP VHF FM radio.* CAP has authorization to use special frequencies in order to communicate with government agencies and our own ground forces. For this purpose CAP aircraft have a VHF FM radio that is separate from the aviation comm radios. This radio is primarily dedicated to air-to-ground communications and is normally operated by the observer or scanner. Several of the frequencies programmed into the radio are frequencies assigned to CAP by the U.S. Air Force, and are used to communicate with CAP bases and ground teams. Others are programmed at the direction of the Wing Communications Officer (e.g., mutual aid, fire, police, park service, forest service, and department of public service); these frequencies almost always require prior permission from the controlling agency before use. [CAP is replacing the older Yaesu and NAT NPX138 radios with the TDFM-136. NPX138 operation is outlined in Attachment 2 of the MART.]



The TDFM-136 is a P25-compliant airborne transceiver capable of operating in the 136 MHz to 174 MHz range (digital or analog) in 2.5 KHz increments. It can have up to 200 operator-accessible memory positions, each capable of storing a receive frequency, a transmit frequency, a separate tone for each receive and transmit frequency, an alphanumeric identifier for each channel, and coded squelch information for each channel. Data can be entered via the 12-button keypad but is normally downloaded from a PC. Operating frequencies, alphanumeric identifiers and other related data are presented on a 96-character, four-line LED matrix display. It is capable of feedback encryption.

National will enter the first four main frequencies (Primary, Secondary, Ground Tactical and Air-to-Ground) and the wing communications officers will enter the rest. Guard 1 will be preset to the Air-to-Ground and Guard 2 to the Primary frequency. Therefore, all you will just have to know is how to *use* the radio. The radio also has a scan function that can scan any or all of the main channels stored in the preset scan lists; scan lists, if enabled, are set by the wing communications officer.

As shown in the figure, the radio simultaneously displays two frequencies. The upper line is the Main (MN) frequency and the lower is the Guard (GD) frequency. Normally, you will be set up to transmit and receive on the Main and be able to receive the Guard frequency. This feature allows mission base to contact you at any time (via Guard), no matter what frequency you are using (Main).

Controls and normal settings:

- The knob above the MN/GD switch is the power switch and controls volume for Main. The knob above the G1/G2 switch is the volume control for Guard.
- The "Squelch" pushbutton is not used (automatic squelch). *Don't push it.*
- The MN/GD toggle switch selects the frequency on which you will transmit *and* receive. It is normally set to MN.
- The G1/G2 toggle switch selects the Guard frequency you are *monitoring* (G1 = Air-to Ground and G2 = Primary). It is normally set to G1.
- The HI/LO toggle switch selects transmitter power (10 watts or 1 watt). It is normally set to HI.

Keypad operation:

- Pressing and holding "4" (Scroll Memory Down) will let you scroll down through the programmed memories (it wraps around). Upon reaching the desired entry, release the button. "6" (Scroll Memory Up) lets you scroll up. [Note: scroll speed increases the longer you hold the buttons.]
- Pressing "5" (Scan) lets you select a scan list to scan, and to start or stop the scan. Once the scan list you want is displayed press # ENTER to start the scan or press * ESC to stop the scan. [Note: this function must be enabled by the wing communications officer for it to work.]
- Pressing and holding "2" (Display - Brighter) will increase display brightness; "8" (Display - Dimmer) decreases brightness.

When you get in the aircraft and power up the radio it should be set to MN, G1 and HI. Use pushbutton 4 or 6 to select the assigned Main frequency (normally Air-to-Ground), and "004 Air/Grd 149.5375" will be displayed on the upper line. The second line should display the Guard 1 frequency (in this case, the same as Main).

As another example, let's say you are working with the U.S. Forest Service and have their frequency on Main. Mission base, noting that you have not called in your "Operations Normal" report, calls you using the G1 frequency. You will hear mission base over Guard (its set to G1), regardless of what is coming over the Main frequency. You simply take the MN/GD switch to GD and answer "Ops Normal," and then return the switch to MN and carry on with the mission.

5. *Required FM radio reports.* As a minimum, the aircrew must report the following to mission base:

- a. Radio check (initial flight of the day)
- b. Take off time ("wheels up")
- c. Time entering a search area
- d. Time exiting a search area
- e. Landing time ("wheels down")
- f. Operations normal ("Ops Normal"), at intervals briefed by mission staff

Additional Information

This task may be performed in conjunction with Task O-2001 (audio panel). More detailed information on this topic is available in Chapter 4 and Attachment 2 of the MART.

Evaluation Preparation

Setup: Provide the student access to aircraft radios.

Brief Student: You are a Mission Pilot trainee asked to set up and use the CAP VHF FM radio, and discuss other CAP-specific communications.

NOTE: The performance measures are designed for the TDFM-136; adjust as necessary for your aircraft.

Evaluation

<u>Performance measures</u>	<u>Results</u>
1. Concerning the aircraft communications radio, discuss:	
a. Frequencies available for SAR/DR use.	P F
b. Proper use of CAP callsigns, including when to use "rescue".	P F
2. Set up and use the CAP VHF FM radio:	
a. Power, volume and squelch controls.	P F
b. Select assigned frequencies (main and guard channels).	P F
c. Keypad controls (scroll and scan).	P F
d. Give required mission FM radio reports (may be simulated).	P F

Student must receive a pass on all performance measures to qualify in this task. If the individual fails any measure, show what was done wrong and how to do it correctly.

O-2001
OPERATE THE AIRCRAFT AUDIO PANEL

CONDITIONS

You are a Mission Observer trainee and must demonstrate how to operate the aircraft audio panel.

OBJECTIVES

Demonstrate and discuss the use of the aircraft audio panel.

TRAINING AND EVALUATION

Training Outline

1. As a Mission Observer trainee, knowing how to set up and use the aircraft audio panel is essential.
2. An audio panel serves as the "hub" for the aircraft's communication and navaid equipment. Whatever type of audio panel is installed in the aircraft, it serves two basic functions:
 - a. Selecting the 'active' radio (COM 1, COM 2, etc.). This is the radio over which you will transmit when you use the push-to-talk switch or the hand mike.
 - b. Allows communication and navigational instruments to be directed to the aircraft's overhead speaker or to the headphones.
3. The position of the switch and the pushbuttons on the audio panel should be checked as part of each preflight. There is no set rules on how they should be set, and settings may vary according to the mission and the airspace you will be flying in. *The important thing is to realize how the panel is set up so that your equipment will function as you need and expect them to function.*
4. KMA 24. One of the most common older audio panels, the KMA 24 is still found in many CAP aircraft. The switch on the right-hand portion of the panel determines which radio you will transmit on; also, if none of the pushbuttons are depressed, the switch setting (e.g., COM 1) determines which radio you are listening to. The pushbuttons are arranged in two rows: the upper row is associated with the aircraft's overhead speaker, and depressing these pushbuttons will direct their associated equipment to the speaker (e.g., press the ADF pushbutton and the ADF will be heard on the speaker); the bottom row is associated with the headphones and serves the same function.



Depressing a pushbutton routes the signal from the associated instrument (e.g., a com radio or the ADF) to the speaker or your headphones, *regardless* of the setting on the COM switch. This comes in handy when you want to monitor two frequencies at the same time. For example, you have Center on the #1 radio and the COM switch in the COM 1 position. You will be flying near a local airport and want to listen to its CTAF. Set the CTAF in the #2 radio and depress the COM 2 PHONE pushbutton. You will now be able to hear both frequencies, but still will only be able to transmit on Center frequency. The CAP FM radio is usually routed through the TEL pushbuttons, and the DF unit is often routed through the ADF pushbuttons.

The two most common mistakes made with this type of audio panel include: transmitting on the wrong frequency because you set the desired frequency in one radio but failed to select the corresponding COM channel; and failing to hear a message over the FM radio because you failed to depress the appropriate pushbutton (usually the TEL pushbutton) to direct the call to the overhead speaker or headphones.

5. PMA7000MS. The PMA7000MS is CAP's newest audio panel, and is installed in conjunction with the new FM radio (TDFM-136). This audio panel was custom-designed to meet CAP SAR operational requirements. In addition to normal audio panel functions, this unit contains an automatic voice-activated (VOX) stereo intercom system with automatic squelch control.

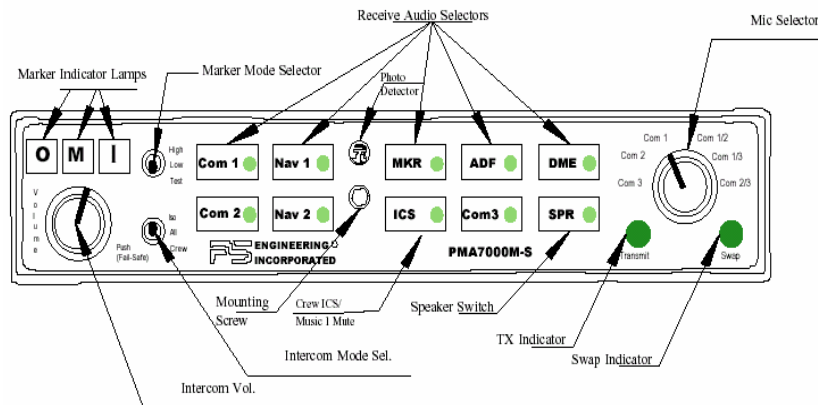

Unit power is turned on and off by pushing the Volume knob. In the Off (or Fail-Safe) position the pilot is connected directly to Com 1 to allow communication capability regardless of unit condition (any time power is removed or turned off the audio selector will be placed in the fail-safe mode). The power switch also controls the audio selector panel functions, intercom, and marker beacon receiver. Unless the Mic Selector is in Com 3 mode, at least one of the selected audio LEDs will be on (Com 1 or Com 2).

The Volume control knob adjusts the loudness of the intercom for the pilot and observer only; it has no effect on selected radio levels or crewmembers' volume level. Adjust the radios and intercom volume for a comfortable listening level for the pilot. [Most general aviation headsets today have built-in volume controls; therefore, crewmember volume can be adjusted on the headset. For best performance your headset microphone must be placed within ¼ inch of your lips, preferably against them. It is also a good idea to keep the microphone out of a direct wind path.]

Mic Selector switch and receiver switches. Receiver audio is selected through two momentary and six latched, push-button, backlit switches. Because the rotary Mic (microphone) Selector switch controls what transceiver is being heard, the Com 1 and Com 2 push-buttons are of the momentary type and do not remain in when selected. Because of this, you will always hear the audio from the transceiver that is selected for transmit by the rotary Mic Selector switch (in other words, you can't transmit without listening to the receiver). You can identify which receivers are selected by noting which of the switch LEDs are illuminated. Push buttons labeled Nav 1, Nav 2, COM 3, DME, MKR (Marker), ADF and SPR (Speaker) are "latched" type switches. When one of these buttons is pressed, it will stay in the "in" position; press the switch again and it will be in the "out" position and remove that receiver from the audio. When selected, the SPR button will place all selected audio on the aircraft's overhead speaker (Note: the speaker amplifier is not active in the split mode).

When the Mic Selector switch is in the Com 1 position, both pilot and observer will be connected to the Com 1 transceiver. Only the person that presses their Push-to-Talk (PTT) will be heard over the aircraft radio. Turning the rotary switch to the Com 2 position will place pilot and observer on the Com 2 transceiver. The PMA7000MS gives priority to the pilot's PTT; if the observer is transmitting and the pilot presses her PTT, the pilot's microphone will be heard over the selected transmitter.

Split Mode. Turning the rotary switch to Com 1/2 places the PMA7000MS into "Split Mode." This places the pilot on Com 1 and the observer on the Com 2 transceiver. An example of this useful feature is when the pilot may want to talk to Air Traffic Control while the observer is checking weather with Flight Watch. Switching to Com 1/3, the pilot will be on Com 1 and the observer will be on Com 3 (the FM radio). In Com 2/3, the pilot is on Com 2 and the observer on Com 3. [Note: In split mode the pilot and observer are usually isolated from

each other on the intercom, simultaneously using their respective radios. Depressing the ICS button in split mode will activate VOX intercom between the pilot and observer positions; this permits intercommunication when desired between the crew. Pressing the ICS button again disables this crew intercom function.]

The table below summarizes the transmitter combinations (substitute Observer for Copilot):

Mic Selector	Normal		Swap	
	Pilot	Copilot	Pilot	Copilot
Com 1	Com 1	Com 1	Com 2	Com 2
Com 2	Com 2	Com 2	Com 1	Com 1
Com 3	Com 3	Com 3	No Swap	No Swap
Com 1/2	Com 1	Com 2	Com 2	Com 1
Com 1/3	Com 1	Com 3	Com 3	Com 1
Com 2/3	Com 2	Com 3	Com 3	Com 2

Intercom Mode. A 3-position toggle switch ("Intercom Mode Sel." in the figure) allows the pilot to tailor the intercom function to best meet the current cockpit situation. The following description of the intercom mode function is valid only when the unit is not in the "Split" mode (as mentioned before, the pilot and observer intercom is controlled with the ICS button when in the split mode).

ISO (up position): The pilot is isolated from the intercom and is connected only to the aircraft radio system. She will hear the aircraft radio reception (and side tone during radio transmissions). The observer will hear the crewmembers' intercom and the back seat scanners will hear the observer's intercom; neither will hear aircraft radio receptions or pilot transmissions.

ALL (middle position): All crewmembers will hear the aircraft radio and intercom.

CREW (down position): The pilot and observer are connected on one intercom channel and have exclusive access to the aircraft radios. Back seat scanners can continue to communicate with themselves without interrupting the pilot or observer.

The following table summarizes the intercom modes (substitute Observer for Copilot):

Mode	Pilot Hears	Copilot Hears	Passengers Hear	Comments
Isolate	A/C Radios Pilot Sidetone (during radio transmission) Entertainment 1 is Muted	Copilot and passenger intercom Entertainment #1	Passenger and Copilot intercom Entertainment #2	This mode allows the pilot to communicate without the others bothered by the conversations. Copilot and passengers can continue to communicate and listen to music
All	Pilot Copilot A/C Radio Passengers Entertainment #1	Copilot Pilot A/C Radio Passengers Entertainment #1	Passengers Pilot Copilot A/C Radio Entertainment #2	This mode allows all on board to hear radio reception as well as communicate on the intercom. Music and intercom is muted during intercom and radio communications
Crew	Pilot Copilot A/C Radio Entertainment #1	Copilot Pilot A/C Radio Entertainment #1	Passengers Entertainment #2	This mode allows the pilot and copilot to concentrate on flying, while the passengers can communicate amongst themselves.

Because improper setup of the audio panel can lead to confusion and missed radio calls, *do not reposition the switch or any of the pushbuttons without consulting with the Pilot-in-Command!*

Additional Information

More detailed information on this topic is available in Chapter 4 and Attachment 2 of the MART.

Evaluation Preparation

Setup: Provide the student access to the aircraft audio panel.

Brief Student: You are a Mission Observer trainee asked about setting up and using the aircraft audio panel.

NOTE: The performance measures are designed for the PMA7000MS; adjust as necessary for your aircraft.

Evaluation

Performance measures

Results

- | | | |
|---|---|---|
| 1. Set up and use the audio panel: | | |
| a. Power and volume controls. | P | F |
| b. Microphone selector switch and receiver switches (describe all positions). | P | F |
| c. Split mode (describe all transmitter combinations). | P | F |
| d. Intercom modes (describe all modes). | P | F |

Student must receive a pass on all performance measures to qualify in this task. If the individual fails any measure, show what was done wrong and how to do it correctly.

DEMONSTRATE OPERATION OF THE AIRCRAFT RADIOS

CONDITIONS

You are a Mission Observer trainee and must demonstrate how to operate the aircraft communications radios and the CAP VHF FM radio.

OBJECTIVES

Demonstrate and discuss the use of the aircraft communications radios and the CAP VHF FM radio.

TRAINING AND EVALUATION

Training Outline

1. As a Mission Observer trainee, knowing how to set up and use the aircraft radios is essential. This enables the observer to assist the pilot during times of heavy workloads, and to communicate effectively with mission base and ground units.

The aircraft radio is the primary means of communication in aviation. To effectively use the radio, mission pilots and observers must be knowledgeable not only of *how* to communicate, but *when* communication is required during CAP missions. Observers may operate the aircraft communications radios in order to reduce pilot workload, and they use the FM radio to communicate with ground units.

Some aviation frequencies are designed for air-to-air communications and may be used by CAP aircraft (or any other general aviation aircraft). 123.1 MHz is the official SAR frequency. 122.75 and 122.85 MHz are air-to-air communications frequencies (and for use by private airports not open to the general public). 122.90 MHz is the Multicom frequency; it *can* be used for search and rescue, *but* is also used for other activities of a temporary, seasonal or emergency nature (note, however, that it is also used by airports without a tower, FSS or UNICOM). Follow your communications plan, if applicable, and don't abuse these frequencies. Look at the sectional to see if 122.90 MHz is used by nearby airports, and always listen before you transmit.

2. *Aviation communications radios.* To establish radio communications (a KX 155 is shown), first tune the communications radio to the frequency used by the clearance or ground station. Almost all general-aviation aircraft transmitters and receivers operate in the VHF frequency range 118.0 MHz to 136.975 MHz. Civil Air Patrol aircraft normally have 720-channel radios, and the desired frequency is selected by rotating the frequency select knobs until that frequency appears in the light-emitting diode display, liquid crystal display, or other digital frequency readout or window.



The 720-channel radios are normally tuned in increments of 50 kilocycles (e.g., 119.75 or 120.00). They can be tuned in increments of 25 kilocycles (e.g., 119.775) pulling out on the tuning knob, but the last digit of the frequency will not be shown in the display (e.g., 119.775 will be displayed as 119.77). [Sometimes, for brevity, air traffic controllers assign such frequencies as "one-one nine point seven seven," meaning 119.775, not 119.770. The operator cannot physically tune the radio to 119.770, and this may be confusing.]

Before transmitting, first *listen* to the selected frequency. An untimely transmission can "step on" another transmission from either another airplane or ground facility, so that *all* the transmissions are garbled. Many pilots have been violated for not complying with instructions that, it was later determined, had been blocked or "stepped on" by another transmission. Next, mentally prepare your message so that the transmission flows naturally without unnecessary pauses and breaks (remember "Who, Where and What"). You may even find it helpful to jot down what you want to say before beginning the transmission. When you first begin using the radio, you may find abbreviated notes to be a convenient means of collecting thoughts with the proper terminology. As your experience level grows, you may find it no longer necessary to prepare using written notes.

Stuck mike

Occasionally, the transmit button on aircraft radio microphones gets stuck in the transmit position, resulting in a condition commonly referred to as a "stuck mike." This allows comments and conversation to be unintentionally broadcast. Worse yet, it also has the effect of blocking all other transmissions on that frequency, effectively making the frequency useless for communication by anyone within range of the offending radio. You may suspect a stuck mike when, for no apparent reason, you do not receive replies to your transmissions, especially when more than one frequency has been involved. You may notice that the 'T' (transmit symbol) is constantly displayed on your communications radio and, in the case of the PMA7000MS audio panel, the transmit (TX) light in the lower right-hand corner is on continuously. You may notice a different sound quality to the background silence of the intercom versus the noise heard when the microphone is keyed but no one is talking. Often the problem can be corrected by momentarily re-keying the microphone. If receiver operation is restored, a sticking microphone button is quite likely the problem.

3. *Callsigns.* CAP aircraft have been authorized to use FAA callsigns, just like the major airlines and commuter air carriers. This helps differentiate us from civil aircraft, air taxis, and many other commercial aircraft. Our FAA authorized callsign is "Cap Flight XX XX," where the numbers are those assigned to each Wing's aircraft. *The numbers are stated in 'group' form.* For example, the C172 assigned to Amarillo, Texas is numbered 4239, where 42 is the prefix identifying it as a Texas Wing aircraft. The callsign is thus pronounced "Cap Flight Forty-Two Thirty-Nine." It is important to use the group form of pronunciation because FAA air traffic controllers expect it of us. [NOTE: There are a few exceptions to this rule, such as when you perform certain counter drug operations. In these rare cases you may be directed to use the aircraft 'N' number as your callsign.]

The initial transmission to a station starts with the name of the station you're calling (e.g., Amarillo Ground), followed by your aircraft callsign. You almost always identify yourself using your aircraft's CAP flight designation. Once you've identified the facility and yourself, state your position (e.g., "at the ramp") and then make your request.

[NOTE: CAP aircraft should use the word "Rescue" in their callsign when priority handling is *critical*. From the example above, this would be "Cap Flight Forty-Two Thirty-Nine Rescue." DO NOT abuse the use of this code; it should only be used when you are on a critical mission *and* you need priority handling. NEVER use the word "rescue" during training or drills.]

4. *CAP VHF FM radio.* CAP has authorization to use special frequencies in order to communicate with government agencies and to our own ground forces. For this purpose CAP aircraft have a VHF FM radio that is separate from the aviation comm radios. This radio is dedicated to air-to-ground communications, and is normally operated by the observer or scanner. Several of the frequencies programmed into the radio are frequencies assigned to CAP by the U.S. Air Force, and are used to communicate with CAP bases and ground teams. Others are programmed at the direction of the Wing Communications Officer (e.g., mutual aid, fire, police, park service, forest service, and department of public service); these frequencies almost always require

prior permission from the controlling agency before use. [CAP is replacing the older Yaesu and NAT NPX radios with the TDFM-136 (below), which will be discussed here.]



The TDFM-136 is a P25-compliant airborne transceiver capable of operating in the 136 MHz to 174 MHz range (digital or analog) in 2.5 KHz increments. It can have up to 200 operator-accessible memory positions, each capable of storing a receive frequency, a transmit frequency, a separate tone for each receive and transmit frequency, an alphanumeric identifier for each channel, and coded squelch information for each channel. Data can be entered via the 12-button keypad but is normally downloaded from a PC. Operating frequencies, alphanumeric identifiers and other related data are presented on a 96-character, four-line LED matrix display. It is capable of feedback encryption.

National will enter the first four main frequencies (Primary, Secondary, Ground Tactical and Air-to-Ground) and the wing communications officers will enter the rest. Guard 1 will be preset to the Air-to-Ground and Guard 2 to the Primary frequency. Therefore, all you will just have to know is how to *use* the radio. The radio also has a scan function that can scan any or all of the main channels stored in the preset scan lists; scan lists, if enabled, are set by the wing communications officer.

As shown in the figure, the radio simultaneously displays two frequencies. The upper line is the Main (MN) frequency and the lower is the Guard (GD) frequency. Normally, you will be set up to transmit and receive on the Main and be able to receive the Guard frequency. This feature allows mission base to contact you at any time (via Guard), no matter what frequency you are using (Main).

Controls and normal settings:

- The knob above the MN/GD switch is the power switch and controls volume for Main. The knob above the G1/G2 switch is the volume control for Guard.
- The "Squelch" pushbutton is not used (automatic squelch). Don't push it.
- The MN/GD toggle switch selects the frequency on which you will transmit *and* receive. It is normally set to MN.
- The G1/G2 toggle switch selects the Guard frequency you are *monitoring* (G1 = Air-to Ground and G2 = Primary). It is normally set to G1.
- The HI/LO toggle switch selects transmitter power (10 watts or 1 watt). It is normally set to HI.

Keypad operation:

- Pressing and holding "4" (Scroll Memory Down) will let you scroll down through the programmed memories (it wraps around). Upon reaching the desired entry, release the button. "6" (Scroll Memory Up) lets you scroll up. [Note: scroll speed increases the longer you hold the buttons.]
- Pressing "5" (Scan) lets you select a scan list to scan, and to start or stop the scan. Once the scan list you want is displayed press # ENTER to start the scan or press * ESC to stop the scan. [Note: this function must be enabled by the wing communications officer for it to work.]

- c. Pressing and holding "2" (Display - Brighter) will increase display brightness; "8" (Display - Dimmer) decreases brightness.

When you get in the aircraft and power up the radio it should be set to MN, G1 and HI. Use pushbutton 4 or 6 to select the assigned Main frequency (normally Air-to-Ground), and "004 Air/Grd 149.5375" will be displayed on the upper line. The second line should display the Guard 1 frequency (in this case, the same as Main).

As another example, lets say you are working with the U.S. Forest Service and have their frequency on Main. Mission base, noting that you have not called in your "Operations Normal" report, calls you using the G1 frequency. You will hear mission base over Guard (its set to G1), regardless of what is coming over the Main frequency. You simply take the MN/GD switch to GD and answer "Ops Normal," and then return the switch to MN and carry on with the mission.

- 5. *Required FM radio reports.* As a minimum, the aircrew must report the following to mission base:
 - a. Radio check (initial flight of the day)
 - b. Take off time ("wheels up")
 - c. Time entering a search area
 - d. Time exiting a search area
 - e. Landing time ("wheels down")
 - f. Operations normal ("Ops Normal"), at intervals briefed by mission staff

Additional Information

More detailed information on this topic is available in Chapter 4 and Attachment 2 of the MART.

Evaluation Preparation

Setup: Provide the student access to aircraft radios.

Brief Student: You are a Mission Observer trainee asked to set up and use the aircraft radios.

NOTE: The performance measures are designed for the KX 155 and the TDFM-136; adjust as necessary for your aircraft.

Evaluation

<u>Performance measures</u>	<u>Results</u>
1. Set up and use the aircraft communications radio:	
a. Power, volume and squelch controls.	P F
b. 50 and 25 kilocycles frequency adjustments.	P F
c. Set in primary and standby frequencies, and switch between them (flip-flop).	P F
d. Discuss proper use of CAP callsigns, including when to use "rescue".	P F
e. Discuss stuck mike indications and strategies.	P F
2. Set up and use the CAP VHF FM radio:	
a. Power, volume and squelch controls.	P F

- | | | |
|---|---|---|
| b. Select assigned frequencies (main and guard channels). | P | F |
| c. Keypad controls (scroll and scan). | P | F |
| d. Give required mission FM radio reports (may be simulated). | P | F |

Student must receive a pass on all performance measures to qualify in this task. If the individual fails any measure, show what was done wrong and how to do it correctly.

O-2003
GRID SECTIONAL CHARTS

CONDITIONS

You are a Mission Observer trainee and must grid and use gridded sectional charts.

OBJECTIVES

Grid a sectional chart using the CAP and the Standardized Lat/Long Grid systems.

TRAINING AND EVALUATION

Training Outline

1. As a Mission Observer trainee, knowing how to grid a sectional chart and use grids is essential in order to assist the mission pilot in planning a search, and to maintain situational awareness during a search.

2. CAP grid system. The sectional grid system used by Civil Air Patrol divides each sectional's area into 448 smaller squares. The latitude and longitude boundaries of each sectional chart are shown below. The St. Louis chart, for example, covers an area that is bounded by the following latitudes and longitudes: North 40° 00' (north boundary), North 36° 00' (south boundary), West 91°-00' (west boundary), and West 84°-00' (east boundary).

Chart	Identifier	North Grid Limit	South Grid Limit	West Grid Limit	East Grid Limit	Total Grids
Seattle	SEA	49-00N	44-30N	125-00W	117-00W	576
Great Falls	GTF	49-00N	44-30N	117-00W	109-00W	576
Billings	BIL	49-00N	44-30N	109-00W	101-00W	576
Twin Cities	MSP	49-00N	44-30N	101-00W	93-00W	576
Green Bay	GRB	48-15N	44-00N	93-00W	85-00W	544
Lake Huron	LHN	48-00N	44-00N	85-00W	77-00W	512
Montreal	MON	48-00N	44-00N	77-00W	69-00W	512
Halifax	HFX	48-00N	44-00N	69-00W	61-00W	512
Klamath Falls	LMT	44-30N	40-00N	125-00W	117-00W	576
Salt Lake City	SLC	44-30N	40-00N	117-00W	109-00W	576
Cheyenne	CYS	44-30N	40-00N	109-00W	101-00W	576
Omaha	OMA	44-30N	40-00N	101-00W	93-00W	576
Chicago	ORD	44-00N	40-00N	93-00W	85-00W	512
Detroit	DET	44-00N	40-00N	85-00W	77-00W	512
New York	NYC	44-00N	40-00N	77-00W	69-00W	512
San Francisco	SFO	40-00N	36-00N	125-00W	118-00W	448
Las Vegas	LAS	40-00N	35-45N	118-00W	111-00W	476
Denver	DEN	40-00N	35-45N	111-00W	104-00W	476
Wichita	ICT	40-00N	36-00N	104-00W	97-00W	448
Kansas City	MKC	40-00N	36-00N	97-00W	90-00W	448
St. Louis	STL	40-00N	36-00N	91-00W	84-00W	448
Cincinnati	CVG	40-00N	36-00N	85-00W	78-00W	448
Washington	DCA	40-00N	36-00N	79-00W	72-00W	448
Las Angeles	LAX	36-00N	32-00N	121-30W	115-00W	416
Phoenix	PHX	35-45N	31-15N	116-00W	109-00W	504
Albuquerque	ABQ	36-00N	32-00N	109-00W	102-00W	448
Dallas-Ft. Worth	DFW	36-00N	32-00N	102-00W	95-00W	448
Memphis	MEM	36-00N	32-00N	95-00W	88-00W	448
Atlanta	ATL	36-00N	32-00N	88-00W	81-00W	448
Charlotte	CLT	36-00N	32-00N	81-00W	75-00W	384
El Paso	ELP	32-00N	28-00N	109-00W	103-00W	384
San Antonio	SAT	32-00N	28-00N	103-00W	97-00W	384
Houston	HOU	32-00N	28-00N	97-00W	91-00W	384
New Orleans	MSY	32-00N	28-00N	91-00W	85-00W	384
Jacksonville	JAX	32-00N	28-00N	85-00W	79-00W	384
Brownsville	BRO	28-00N	24-00N	103-00W	97-00W	384
Miami	MIA	28-00N	24-00N	83-00W	77-00W	384

The process begins by dividing the whole area into twenty-eight *1-degree* grids, using whole degrees of latitude and longitude. Then each 1-degree grid is divided into four *30-minute* grids, using the 30-minute latitude and longitude lines as shown in Figure 8-22. Finally, each of the 30-minute grids is divided into four *15-minute* grids, using the 15- and 45-minute latitude and longitude lines.

Next, the grid squares are numbered 1 through 448 beginning usually with the most northwest square on the entire sectional, and continuing straight east through number 28. The numbering resumes in the second row, with number 29 placed beneath number 1, 30 beneath 2, and so on through 56. The third row begins with number 57 beneath numbers 1 and 29, and continues through 84. Numbering continues through successive rows until all 448 squares have a number.

In cases where two sectionals overlap one another, the Civil Air Patrol always uses the numbering system for the western-most chart of the two in question. You can see this where the overlap area between 90° 00' and 91° 00', shown in the first 4 vertical columns, is identified with Kansas City (MKC) grid numbering, not St. Louis. Note too that, since the Kansas City grid numbering is used in this overlap area, the first 4 columns of the St. Louis grid numbering system are omitted. Several other such overlaps exist within the grid system.

When circumstances require, a 15-minute grid can be divided into 4 more quadrants using 7 1/2 minute increments of latitude and longitude, creating 4 equal size grids that are approximately 7 1/2 miles square. The quadrants are then identified alphabetically - A through D - starting with the northwest quadrant as A, northeast as B, southwest as C and southeast as D, as shown below. A search area assignment in the southeast quadrant may be given as "Search STL 5D."

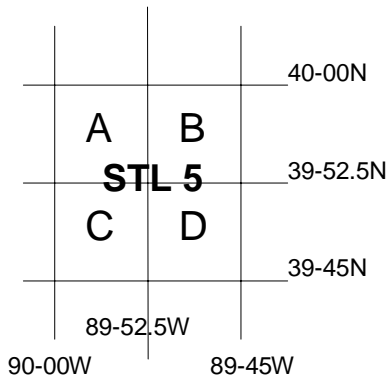

Pinpointing an area within the grid system becomes easy once you gain familiarity with the grids' many uses. You soon will be able to quickly plot any area on a map and then fly to it using the basic navigation techniques already discussed.

3. Another means of designating a grid system is the Standardized Latitude and Longitude Grid System. It has an advantage over the sectional standardized grid in that it can be used on any kind of chart that has lines of latitude and longitude already marked. In this system, 1-degree blocks are identified by the intersection of whole numbers of latitude and longitude, such as 36-00N and 102-00W. These points are always designated with the latitude first, such as 36/102, and they identify the area north and west of the intersection of these two lines. In the figure below, the gray shading identifies section 36/102.

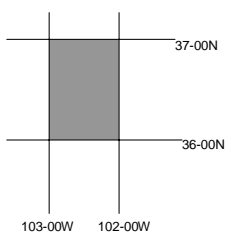

Next, the 1-degree grid is divided into 4 quadrants using the 30-minute lines of latitude and longitude. Label each quadrant A through D; the northwest quadrant being 36/102A, the northeast 36/102B, the southwest 36/102C, and the southeast 36/102D as shown in the figure below (left). Each quadrant can also be divided into four sub-quadrants, labeled AA, AB, AC, and AD, again starting with the most northwest and proceeding clockwise, as shown the figure below (right). This grid system works on any chart that has latitudes and longitudes printed on it.

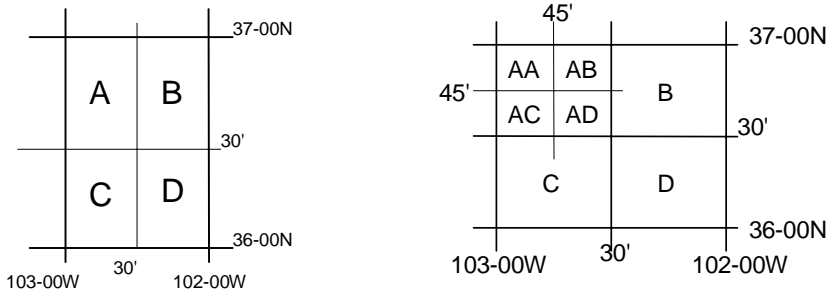

Additional Information

More detailed information and figures on this topic are available in Chapter 8 of the MART. Attachment 1 of the MART is a reproduction of Attachment E of the *U.S. National SAR Supplement to the International Aeronautical and Maritime SAR Manual*.

Evaluation Preparation

Setup: Provide the student with Appendix E of the *U.S. National SAR Supplement to the International Aeronautical and Maritime SAR Manual* (Attachment 1 of MART), a sectional chart and a plotter. Give the student a sectional (may be out-of-date) and a gridding assignment.

Brief Student: You are an Observer trainee asked grid a sectional chart, using both the CAP and the Standardized Latitude and Longitude Grid systems.

Evaluation

<u>Performance measures</u>	<u>Results</u>
Given Appendix E of the <i>U.S. National SAR Supplement to the International Aeronautical and Maritime SAR Manual</i> (Attachment 1 of MART), a sectional chart, and a plotter:	
1. Grid a sectional using the CAP grid system.	P F
2. Given coordinates, draw a grid on the sectional using the Standardized Latitude and Longitude Grid System.	P F

Student must receive a pass on all performance measures to qualify in this task. If the individual fails any measure, show what was done wrong and how to do it correctly.

O-2004
USE A POD TABLE

CONDITIONS

You are a Mission Observer trainee and must demonstrate basic knowledge of search planning and the use of the POD table.

OBJECTIVES

Demonstrate basic knowledge of how search planners determine the Maximum Area of Possibility and Probability Area. Use a POD table to discuss the advantages and disadvantages of various search altitudes and speeds over various types of terrain.

TRAINING AND EVALUATION

Training Outline

1. As a Mission Observer trainee, basic knowledge of search planning and being able to use the POD table is helpful.
2. The first task in planning a search and rescue mission is to establish the most probable position of the crash site or survivors. If witnesses or other sources provide reliable information concerning an accident, the location may be established without difficulty. If there is little or no information, the planning section chief faces a more difficult task. Regardless of the information available, the planning section chief always prepares a chart to assist in focusing the search and locating the crash site or survivors as quickly as possible.
3. When defining search area limits, the planning section chief first sketches the maximum possibility area. This can focus the initial search in the most likely area and allows use of the charted area to help screen sightings and other reports. Again, the area is roughly circular, centered on the last known position of the missing aircraft. The radius approximates the distance the objective aircraft might have traveled, given the amount of fuel believed aboard at its last known position, and the wind direction and speed. The area is circular because it's always possible the missing pilot may have changed directions following his last known position and flown until his fuel was exhausted.
4. To chart the Maximum Area of Possibility, the planning section chief requires the missing aircraft's last known position, wind direction and velocity, and an estimate of the missing aircraft's fuel endurance and airspeed. If none of this information is available the task is much more difficult, and the search plan is usually based on an assumption that the missing aircraft is located along or near its intended course.
5. Plotting the probability area, the area in the possibility circle where the searchers are most likely to find the aircraft, is the second major factor in search planning. The probability area is determined by the accuracy of the last known position (LKP) in the possibility circle. When this information is not available, the planning section chief must rely on less specific secondary sources of information.

Based on experience and the accuracy of available information, the planning section chief defines an area of highest priority to initiate the search. The first search area may be called probability area one: this area begins around the last known position, extends along the intended route, and ends around the intended destination. If a search of probability area one produces negative results, the search may be expanded to cover probability area two, an extension of area one. If this search is unsuccessful, the search area is adjusted once more.

6. Organization is an important element in search planning. The time it takes to locate downed aircraft or survivors could depend on the definition and charting of the search area. As an observer, you should become familiar with each designated search area before the mission is launched. You should use current charts and maps which will enable you to provide additional navigational assistance in accurately positioning the search aircraft over the properly designated area.

7. The size of the search objective, weather, visibility, and ground cover in the search area must be considered when determining the altitude and airspeed for a visual search. Over non-mountainous terrain, a search altitude between 800 and 2000 feet above the terrain is normally used for a visual search. The search visibility and the terrain conditions may affect this selection. As altitude decreases below 500 feet, search effectiveness may actually decrease, due to the "rush effect" of objects on the ground passing through the scanner's field of view more rapidly.

Depending upon the number of search aircraft available, planners may also consider the desired probability of detection when selecting an altitude for the search pattern. Although a probability of detection chart is normally used to estimate POD *after* a search, its use here allows planners to predetermine a mission's chance of success. The POD table shows data for: open, flat terrain; hilly terrain and/or moderate ground cover; and very hilly and/or heavily covered terrain. To the right in the columns beneath "Search Visibility" you see what are, in this case, the desired probabilities of detection. Looking at the open/flat terrain and using 1-mile track spacing, you can see that all three altitudes give at least 50% POD, but a search at 1000 feet above the terrain gives 60%, or 10% *more* POD, than does a search at 500 feet. Over open terrain, where flight and search visibility are not limiting factors, the table demonstrates that a higher altitude is more likely to yield positive results on a single sortie. Notice that the highest POD, 85%, is obtained when flying at 1,000 feet above the ground using a track spacing of 0.5 nm.

OPEN, FLAT TERRAIN					MODERATE TREE COVER AND/OR HILLY					HEAVY TREE COVER AND OR VERY HILLY				
SEARCH ALTITUDE (AGL)	SEARCH VISIBILITY				SEARCH ALTITUDE (AGL)	SEARCH VISIBILITY				SEARCH ALTITUDE (AGL)	SEARCH VISIBILITY			
Track Spacing	1 mi	2 mi	3 mi	4 mi	Track Spacing	1 mi	2 mi	3 mi	4 mi	Track Spacing	1 mi	2 mi	3 mi	4 mi
500 Ft					500 Ft					500 Ft				
.5 mi	35%	60%	75%	75%	.5 mi	20%	35%	50%	50%	.5 mi	10%	20%	30%	30%
1.0	20	35	50	50	1.0	10	20	30	30	1.0	5	10	15	15
1.5	15	25	35	40	1.5	5	15	20	20	1.5	5	5	10	15
2.0	10	20	30	30	2.0	5	10	15	15	2.0	5	5	10	10
700 Ft					700 Ft					700 Ft				
.5 mi	40%	60%	75%	80%	.5 mi	20%	35%	50%	55%	.5 mi	10%	30%	30%	35%
1.0	20	35	50	55	1.0	10	20	30	35	1.0	5	10	15	20
1.5	15	25	40	40	1.5	5	15	20	25	1.5	5	5	10	15
2.0	10	20	30	35	2.0	5	10	15	20	2.0	5	5	10	10
1000 Ft					1000 Ft					1000 Ft				
.5 mi	40%	65%	80%	85%	.5 mi	25%	40%	55%	60%	.5 mi	15%	20%	30%	35%
1.0	25	40	55	60	1.0	15	20	30	35	1.0	5	10	15	20
1.5	15	30	40	45	1.5	10	15	20	25	1.5	5	10	10	15
2.0	15	20	30	35	2.0	5	10	15	20	2.0	5	5	10	10

If weather or visibility are not limiting factor, why then don't you just always elect to fly *that* track spacing at 1,000 feet, and always try to obtain that highest of probabilities of detection? You should recall, from the earlier maximum probability area, that you start with a very large area and then try to focus your efforts on smaller probability areas within that larger area. If the incident commander has received a number of leads that have reduced the probable area to a small size, he might task you to fly exactly that track spacing and altitude. If the area is not so small, and you try to fly 1/2- rather than 1-mile track spacing, you will obviously take *twice* as long to cover the whole area.

8. Execution of search patterns. The incident commander and his staff take into consideration many variables including weather, visibility, aircraft speed, and availability of aircraft and crew resources, experience, and urgency of the situation when developing the search plan. Similarly, the planning section chief considers many variables when selecting the search pattern or patterns to be used. Individual search patterns are covered in

chapters that follow. All questions about how the search is to be conducted must be resolved at the mission briefing. When airborne, crews must focus on executing the briefed plan instead of second-guessing the general staff and improvising. If, for whatever reason, you deviate from the planned search patterns it is imperative that you inform the staff of this during your debriefing.

Additional Information

More detailed information and figures on this topic are available in Chapter 9 of the MART.

Evaluation Preparation

Setup: Provide the student with search planning figures (e.g., Chapter 9 of the MART) and a POD table.

Brief Student: You are an Observer trainee asked to discuss basic search planning and use a POD table.

Evaluation

<u>Performance measures</u>	<u>Results</u>
1. Discuss how search planners determine the Maximum Area of Possibility and the Probability Area.	P F
2. Using a POD table, discuss the advantages and disadvantages of various search altitudes and speeds over the three major types of terrain.	P F
3. Discuss the importance of proper execution of search patterns.	P F

Student must receive a pass on all performance measures to qualify in this task. If the individual fails any measure, show what was done wrong and how to do it correctly.

O-2005
OPERATE THE AIRCRAFT DIRECTION FINDER

CONDITIONS

You are a Mission Observer trainee and must operate the aircraft Direction Finder.

OBJECTIVES

Operate the aircraft Direction Finder (DF) in both the Alarm and DF modes, and discuss how the DF should respond during a typical mission.

TRAINING AND EVALUATION

Training Outline

1. As a Mission Observer trainee, knowing how the aircraft DF works and how to operate it is essential.
2. L-Tronics DF. The L-Tronics LA series Aircraft Direction Finder, the most common DR unit found in CAP aircraft, consists of VHF and UHF receivers, two- or three-element yagi antennas (normally mounted on the bottom of the aircraft) and circuitry. The controls consist of a frequency selector switch, an alarm toggle switch (works like a light switch), and a dual-knob control switch for volume (inner knob) and sensitivity (outer knob). There are two indications: a DF meter and a signal Strength meter. [Note: Some have only the DF meter, but the operation is the same.]



The DF unit is normally connected to the aircraft audio system. This connection allows an audible as well as a visual alarm when an ELT signal is detected in ALARM mode.

The Alarm mode is the normal mode for routine conditions. It enables the pilot to monitor the emergency frequency (121.5 MHz) without dedicating a communications radio to the task. **DO NOT USE THIS MODE DURING A DF SEARCH** because the DF function is disabled in the Alarm mode.

a. Normal setup. To select the Alarm mode, place the Alarm toggle switch on (up). Set the SENSitivity so that the needle just comes on-scale and the VOLume to a comfortable level (the ear will detect a weak signal far sooner than the alarm). [Note: The Alarm mode is designed to work with weak signals; if an ELT is transmitting nearby and the unit is set to full sensitivity, the receiver may overload.]

b. DF setup. If an ELT activates the Alarm, turn the Alarm toggle switch off (down) and verify or select 121.5 on the frequency switch. This activates the DF function and allows you to track the signal. Set the SENSitivity to maximum and the VOLume to a comfortable level. **The Alarm mode must not be used during a DF search because the DF function is not operable in the Alarm mode (toggle switch up).**

c. Searching for an ELT signal. The pilot should climb to an altitude of *at least* 3000 to 4000 feet AGL, if possible, and fly to the area of the reported ELT signal (but remember, an ELT search begins the minute you take off). If the ELT cannot be heard in the expected area, climb to a higher altitude. If this fails to acquire the signal, start a methodical search (e.g., area or expanding square). Unless the beacon is known to be a 406 MHz

EPIRB or a military beacon (which uses 243 MHz), switch between 121.5 and 243 MHz at least once each minute until a signal is heard. All civil beacons and some military beacons transmit on both frequencies.

d. Phases of a typical ELT search:

Initial heading. When first heard, the ELT signal will probably be faint and will build slowly in strength over a period of several minutes. Continue flying until a reasonable level of signal is acquired. The DF needle should deflect to one side and the Strength needle should come on-scale. Resist the urge to turn immediately and follow the needle; instead, make a 360° turn at no more than a 30° bank to ensure you get two needle centerings (approximately 180° apart) to verify the heading. When the turn is complete, center the DF needle and fly toward the ELT. Note your heading (write it down) for reference.

If the ELT is heard on both 121.5 and 243.0 MHz, compare the headings. If they differ by more than 45° or if the turn produces multiple crossovers, try a new location or climb to a higher altitude to escape from the reflections.

While flying toward the ELT the DF needle may wander back and forth around center at 10- to 30-second intervals. This is caused by flying through weak reflections and should be ignored. Fly the heading that keeps needle swings about equal in number, left and right.

Signal fade. Don't become concerned if the signal slowly fades out as you fly towards the ELT. If this happens, continue on your heading for at least six minutes. If you are still headed toward the ELT the signal should slowly build in strength in three or four minutes and be somewhat stronger than before the fade. If the signal does not reappear, return to where the signal was last heard and try a different altitude.

Getting close. As you get close to the ELT the signal will get stronger, and you will have to periodically adjust the SENSitivity control to keep the signal strength needle centered (*do not* decrease the VOLume control as this could overload the receiver). You also need to do this if the DF needle gets too sensitive. Periodically yaw the aircraft and observe the DF needle respond (left and right).

Passing over the ELT. A "station passage" is often seen as a rapid fluctuation in signal strength and confused DF readings. Yaw the aircraft to see if the course has reversed (needle goes in the direction of the aircraft turn). If the course has reversed, continue on your heading for a few minutes. Then turn and make several confirmation passages from different angles while continuing your visual search.

3. Becker SAR DF 517. The SAR DF 517 is a precision direction finder was developed for professional SAR (search and rescue) purposes. It has the ability to bear and analyse traditional 121.5 MHz and 243.0 MHz emergency frequencies in the VHF and UHF bands, maritime radio channel 16, and the new digitally encoded 406.025 MHz COSPAS/SARSAT emergency signal. This system incorporates a newly developed and patented antenna (small, rugged and wideband), as well as sophisticated bearing analysis algorithms, allowing delivery of a quick and steady indication for both the 121.5 and 406.025 MHz signals. It also has the ability to track a wide range of training frequencies for training exercises. The direction finder was developed for working under stressful mission conditions such as in an aircraft, helicopter or vehicle. The SAR DF 517 has two modes of operation:

a. Emergency Mode. This mode is used for actual SAR missions. In this mode the unit will search for 121.5 MHz, 406.025 MHz, Marine Channel 16 and COSPAS/SARSAT Emergency Signal Transmissions. Depending on selection, the unit will either SCAN all of these frequencies or search on a single selected frequency. To operate the unit in the emergency mode, follow the checklist below:

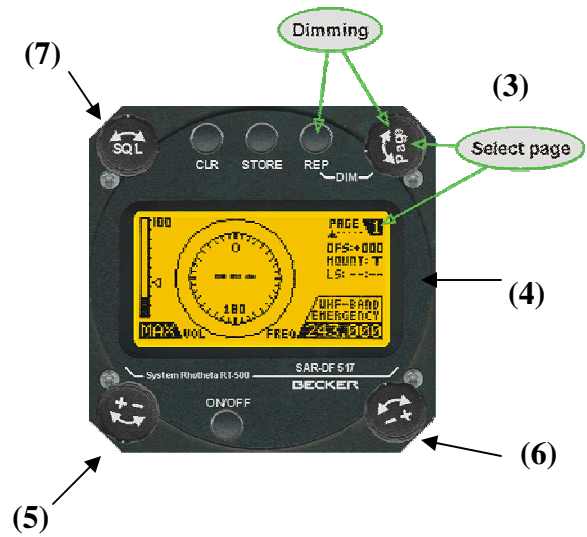
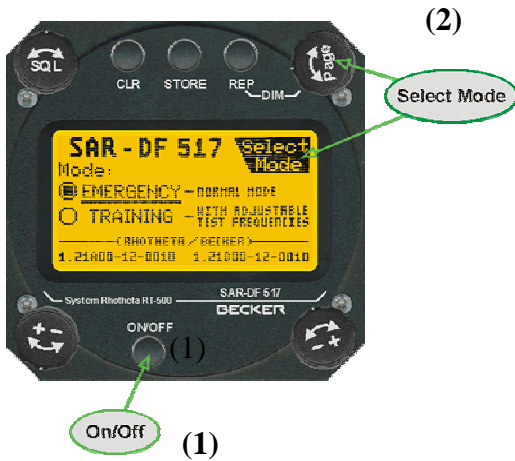

- 1) Turn ON
- 2) Select EMERGENCY
- 3) Select PAGE 1
- 4) Verify Correct Antenna Mounting
- 5) Turn Volume ON
- 6) Select EMERGENCY Frequency or SCAN mode.
- 7) SET SQUELCH LEVEL! (Set just above noise level.)

b. Training Mode. This mode is used for practice exercises. In this mode the unit will search for specific training frequencies entered by the operator, can also SCAN a group of training frequencies, but **EMERGENCY frequencies are ignored when in the training mode.** To operate the unit in the training mode, follow the checklist below:

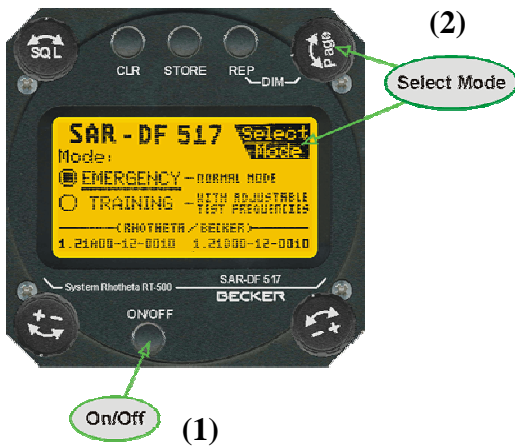

- 1) Turn ON
- 2) Select TRAINING

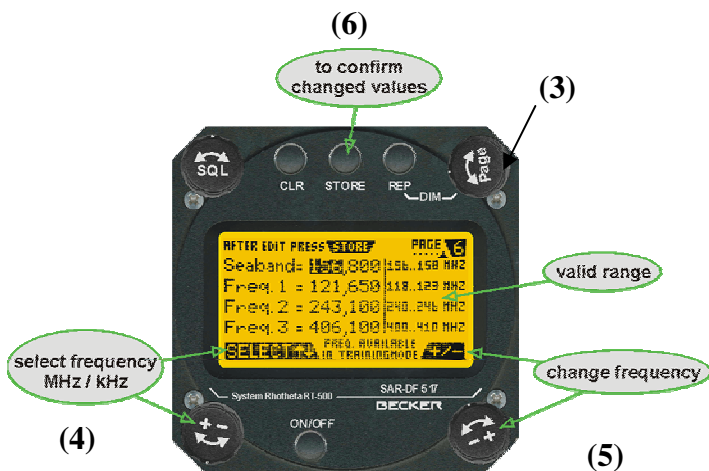

3) Select PAGE 6

4) Select Training Frequency Band

5) Set/Verify Training Frequency. Change only if needed.

6) Press STORE button to save any changes made to training frequency. Not necessary if no changes made.

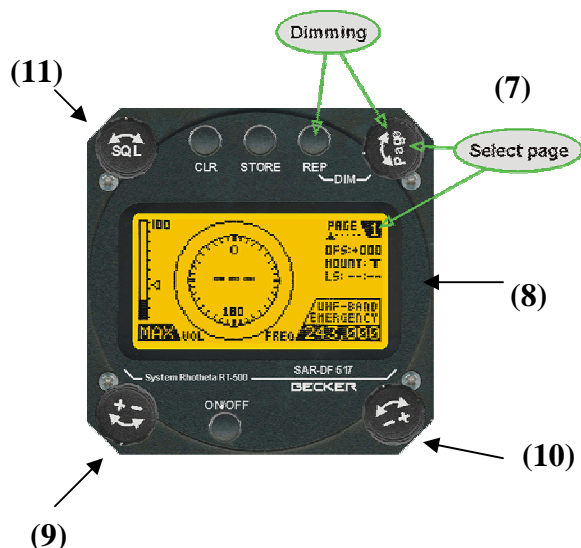

7) Select PAGE 1

8) Verify Antenna Mounting

9) Turn Volume ON

10) Select Training Frequency or SCAN mode.

11) SET SQUELCH LEVEL! (Set just above noise level.)

c. Becker SAR DF 517 Highlights:

1) SQUELCH Adjustment. It takes some practice to learn the correct setting of the squelch control. If the squelch is set to high, you may not be able to receive the ELT signal. If the squelch is set to low (in the noise level) you will receive erroneous ELT signals that may tend to “bounce” around the screen.

2) Don't be afraid to play with the squelch adjustment while in flight. You will quickly learn how to tell the difference between a valid ELT signal and an erroneous signal cause by noise.

3) Be sure to monitor your COMM radio also. Listen for the characteristic ELT “whooping” signal on the correct frequency (usually 121.5 MHz for EMERGENCIES or 121.775 for TRAINING). If you can hear the ELT on your COMM radio, but it is not being indicated on the DF-517, your squelch setting is probably too high.

4) The PILOT should not be watching the DF-517 display. The OBSERVER should be watching the display and giving bearing directions to the pilot. The pilot's job is to provide the crew a safe flight environment. FLY SAFE!

Additional Information

DF is covered in Task O-2108, *Assist in ELT Searches*, and may be performed concurrently with this task. More detailed information and figures on this topic are available in Chapter 10 and Attachment 2 of the MART as well as the User Manual for the Becker SAR-DF 517.

Evaluation Preparation

Setup: Provide the student with an aircraft and pilot, and a practice beacon.

Brief Student: You are a Mission Observer trainee asked to set up the aircraft DF unit and assist in locating a practice beacon.

Evaluation

<u>Performance measures</u>	<u>Results</u>
1. Describe how the aircraft DF works.	P F
2. Set up the DF.	P F
2. Use the DF during a typical ELT search. Discuss how the DF should respond during the initial phase (include signal fade), when you are getting close, and when you pass over the practice beacon.	P F

Student must receive a pass on all performance measures to qualify in this task. If the individual fails any measure, show what was done wrong and how to do it correctly.

O-2006
PERFORM ELT SEARCHES

CONDITIONS

You are a Mission Pilot trainee and must perform ELT searches.

OBJECTIVES

Locate an Emergency Locator Transmitter (practice beacon) using the homing and wing null ELT search methods. Discuss the aural and metered search methods, and reflection and interference.

TRAINING AND EVALUATION

Training Outline

1. As a Mission Pilot trainee, knowing how to plan for and locate an Emergency Locator Transmitter (ELT) is essential. There are several methods that can be used, the most common of which are the homing and wing null methods. You should also be familiar the aural and metered search method, and how reflections and signal interference can affect the search.

2. *Homing* is an electronic search method that uses the Direction Finder (DF) to track the ELT signal to its source. Tune the direction finder (DF) to the ELT operating frequency; the pilot will fly the aircraft to the transmitter. ELT's may transmit on either 121.5 MHz VHF, 243.0 MHz UHF, or both frequencies simultaneously. These emergency frequencies are *usually* the ones monitored during a search, but homing procedures can be used on any radio frequency to which *both* a transmitter and DF receiver can be tuned.

a. L-Tronics DF Unit. First you have to determine the direction to the ELT. When you fly directly toward a signal, the left/right DF needle remains centered. However, when you head directly *away* from the signal, the needle also centers. A simple, quick maneuver is used to determine if you are going toward or away from the signal. Starting with the left/right needle centered, the pilot turns the aircraft in either direction so that the needle moves away from center. If he turns left, and the needle deflects to the right, the ELT is in front. If the pilot turns back to the right to center the needle, and then maintains the needle in the center, you will eventually fly to the ELT. If, in the verification turn, the pilot turns left and the needle swings to the extreme left, then the ELT is behind you. Continue the left turn until the needle returns to the center. You are now heading toward the ELT, and as long as the pilot maintains the needle in the center, you will fly to the ELT.

Flying toward the ELT, maintaining the needle in the center of the indicator *is* the actual homing process. If the needle starts to drift left of center, steer slightly left to bring the needle back to the center. If it starts to drift right, turn slightly back to the right. Once you have completed the direction-verification turn, you will not need large steering corrections to keep the needle in the center.

When passing over the ELT or transmission source, the left/right needle will indicate a *strong* crossover pattern. The needle will make a distinct left-to-right or right-to-left movement and then return to the center. This crossover movement is *not* a mere fluctuation; the needle swings fully, from one side of the indicator to the other and then returns to the center.

During homing you may encounter situations where the needle *suddenly* drifts to one side then returns to center. If the heading has been steady, and the needle previously centered, such a fluctuation may have been caused by a signal from a second transmitter. Another aircraft nearby can also cause momentary needle fluctuations that you might not hear, but the needle in the DF will react to it. Signal reflections from objects or high terrain can also cause needle fluctuations at low altitudes in mountainous terrain or near metropolitan areas.

b. Becker SAR-DF 517. Just like when using the L-Tronics DF, you will need to determine the bearing to the target. With the Becker DF, you will essentially follow the directions on pages of the display.



Page 1: 360° bearing

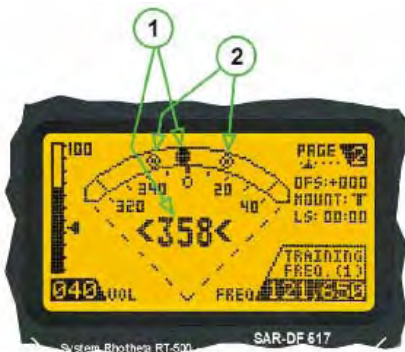

Page 2: expanded $\pm 45^\circ$



Page 3: bearing text

1) Relative Bearing value. It is very important to realize that this is a relative bearing that is relative to the nose of the aircraft, NOT the heading to be flown.

2) Spread Maximum deviation of un-averaged bearing. Good bearing results even with a spread of 45° as a result of the averaging procedure. Note: as you approach near the ELT and the signal becomes very strong, the spread will narrow.

3) Receive level Field strength. Page 1 shows approximately 50%, Page 2 shows approx. 75%

4) Squelch level Squelch level must be above the noise level without a received signal.

5) Offset Corrects for antenna alignment (adjusted in the edit-menu).

6) Mounting Page 1 shows a BOTTOM mounted antenna. Page 3 shows TOP mounted.

7) LS: ---:--- Internal timer (LS meaning last signal) indicating the time since the last signal was received, displayed in min /sec

How do I read the above displays?

- Page 1 indicates that the target is 2 degrees to the right, so the observer would tell the pilot to turn 2 degrees right to center the ball at the top of the display.
- Page 2 indicates that the target is 2 degrees to the left, so the observer tells the pilot to turn two degrees to the left to center the ball at the top of the display.
- Page 3 indicates that the target is 6 degrees to the right, so the observer tells the pilot to turn 6 degrees to right (there is no ball displayed on this page).

How do you know when you are over the target?

- The “ball” will swing to the 180 degree position on PAGE 1 just after you pass over the target.

- When you are exactly over the target you may notice a “cone of influence” similar to passing over a VOR during which the signal may be lost momentarily before it swings to 180 degrees.

3. *Wing null*. The wing null (or wing shadow) method is based on the assumption that the metal skin of the search aircraft’s wing and fuselage will block incoming ELT signals from the receiving antenna during steep-banked turns.

Due to the length of the description of this search method and the number of figures, refer to the "Wing Shadow method (wing null)" section of the Mission Aircrew Reference Text (MART) for details.

4. The *aural* (or hearing) search technique is based on an assumption that an ELT's area of apparent equal signal strength is circular.

Please refer to the "Aural (or hearing) search" section of the MART for details.

5. To employ the *metered* search method, the observer uses a signal strength meter to monitor the ELT signal. Once the aircraft enters the search area, the observer plots two positions of equal meter strength.

Please refer to the "Metered search" section of the MART for details.

6. Signal reflection and interference. Radio signals reflect off terrain and manmade objects, and this can be a problem for search and rescue teams. In an electronic search, it is vitally important to know if the equipment is reacting to reflected signals and what you can do to overcome the problem.

Please refer to the "Signal Reflection and Interference" section of the MART.

Additional Information

Using the DF is covered in Task O-2005 (Operate the Aircraft DF), and may be performed concurrently with this task. More detailed information and figures on this topic are available in Chapter 10 and Attachment 2 of the MART and the user’s manual for the Becker SAR-DF 517..

Practice

Setup: The student needs access to an aircraft with an operable DF, a sectional and or a map of the practice area. Place a practice beacon in a suitable location for each type (method) of DF search. [Note: If you normally operate in or near congested airspace, you should conduct some of these practice sorties under ATC control inside the congested airspace.]

For the first lesson it is best if the trainer flies the aircraft and let the student concentrate on the DF unit. Where possible, have the student direct the pilot (particularly for headings) by interpreting DF signals. Thereafter the trainer should let the student perform as much of the search duties as is practical.

As a minimum, the student should practice the homing and wing null search methods. Demonstration of the aural and metered search methods is desirable, but they may be simulated. [Note: It is highly desirable to have a ground crew available during practice. The observer can then lead the ground crew to the area where the practice beacon is located and let the ground crew find the beacon.]

The student should start out searching for a practice beacon located in an open area where the signal will not be reflected. At first, the practice beacon's location should be clearly marked (e.g., using an adjacent signal panel or wreckage simulations) so the student can see the results of his efforts.

After the student has successfully demonstrated basic proficiency, place the practice beacon in an open area but do not mark its location. Have the student locate the beacon and tell you its approximate location. This provides a good simulation of a night search. After the student has demonstrated proficiency, practice at least one DF (using the homing and wing null methods) at night.

After the student has mastered the basic ELT search methods, place a practice beacon in locations where the signal is weakened or reflected (e.g., inside a hanger, along a metal fence, or near a power transmission line).

Evaluation Preparation

Setup: Provide the student with an aircraft and pilot, a sectional and/or map of the local area. Place a practice beacon in a suitable location for each type of ELT search.

Brief Student: You are a Mission Pilot trainee asked to perform ELT searches.

NOTE: The performance measures are designed for the L-Tronics DF; adjust as necessary for your aircraft.

Evaluation

<u>Performance measures</u>	<u>Results</u>	
1. Locate a practice beacon using the following search methods:		
a. Homing to a non-reflected signal.	P	F
b. Homing to a non-reflected signal at night (combine with 1.d, if possible).	P	F
c. Homing to a reflected signal.	P	F
d. Wing null to a non-reflected signal (one during the day and one at night).	P	F
2. Locate a practice beacon using the following search methods (may be simulated):		
a. Aural.	P	F
b. Signal.	P	F
3. Discuss night and IFR searches, with particular emphasis on the hazards and precautions.	P	F
4. Discuss signal reflection and interference.	P	F

Student must receive a pass on all performance measures to qualify in this task. If the individual fails any measure, show what was done wrong and how to do it correctly.

LOCATE AND SILENCE AN ELT ON THE GROUND

CONDITIONS

You are a Mission Observer trainee and must locate and silence an ELT on the ground.

OBJECTIVES

Locate and silence an ELT on the ground, and discuss the legal issues involved.

TRAINING AND EVALUATION

Training Outline

1. As a Mission Observer trainee, knowing how to locate and silence an Emergency Locator Transmitter (ELT) on the ground is essential. If you don't have a ground crew and you have determined the ELT signal is coming from an airfield, you can land and find the offending aircraft. You can use a hand-held DF unit (Little L-Per or Tracker) and/or a hand-held radio to locate the aircraft.

NOTE: Aircrews will not conduct searches off the main airport property as they are not normally equipped to do so. If aircrews conducting an airport search suspect an aircraft crash off the field, they should request additional assistance from local authorities and support from a CAP ground or urban direction finding team to locate the crashsite.

2. Sometimes you locate the hanger where the signal is coming from and find it is full of aircraft. Two methods are very useful in locating the ELT under these circumstances:

Signal-offset method

You can take advantage of the fact that reflected signals are generally weaker by tuning a hand-held radio further away from the primary frequency (signal-offset). Assuming the ELT is transmitting on 121.5, tune the radio to 121.55. Toggle back and forth between the two frequencies as you approach the suspected location until you hear a signal on 121.55. As you home in make 121.55 the primary and set 121.6 on the radio and repeat the process (you may even work up to 121.7). As you get further away from the initial frequency the area where the signal will break through the squelch becomes smaller and smaller (you can even turn up the squelch to get further isolation).

Use a hand-held radio without its antenna

Hold the radio by one of the suspect aircraft (its ELT antenna, if mounted on the exterior) and turn the volume down until you can just hear the signal, then move to the next suspect aircraft and hold the radio next to its antenna. If the signal is stronger you probably have it; if it is weaker or cannot be heard it's probably the other aircraft. If needed, repeat with the radio's antenna removed (*Warning: Do not key the radio's transmitter while it's antenna is removed!*). [Note: You may also incorporate portions of the signal-offset method with this method.] Another technique is to slip an aluminum foil "sleeve" over the suspect ELT antenna while holding the radio by the antenna; if the signal fades significantly, you have found the signal.

3. Once you have determined which aircraft the signal is coming from, you have to find the (physical) ELT. Most are located in the rear of the aircraft; also look for remote switches. The following gives some general locations:

- a. Single-engine Cessna: right side of the upper baggage area immediately aft of the baggage door.
- b. Multi-engine Cessna: left side of the fuselage just forward of the horizontal stabilizer. Accessed through a small push-plate on the side of the fuselage.

- c. Single- and multi-engine Piper: in the aft fuselage. Accessed through a small access plate on the right side of the fuselage (need a screwdriver).
 - d. Single- and multi-engine Bonanza: in the aft fuselage. Accessed through a small access plate on the right side of the fuselage (need a screwdriver).
 - e. Large piston twins (e.g., King Air) or small jets: if installed its probably in the rear section. No visible antenna. May have a small round push-plate that gives you access to the switch with your finger.
4. The preferred method of silencing a transmitting ELT is to have the owner (or a person designated by the owner) turn it off and disconnect the battery; second best is just turning it off. Some owners will take the switch to OFF and then back to ARMED; monitor the emergency frequency for several minutes afterwards to ensure the ELT doesn't resume alarming. If you cannot find the owner (or designee), you may have to install an aluminum foil 'tent' to limit the ELT signal range.

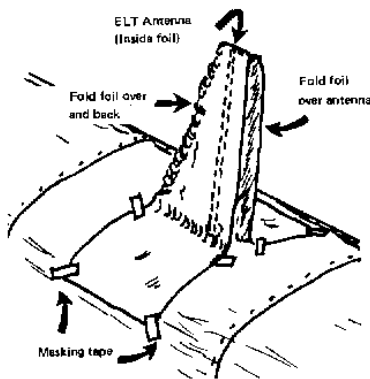

Take a piece of foil about one foot wide by about five feet long. Place the tip of the ELT antenna in the center of the foil and fold the foil down on both sides of the antenna. Let the ends lay flat against the fuselage; the flaps *must* extend at least 18" beyond the antenna. Fold the two sides of the 'tent' together to completely enclose the antenna and *securely* tape the foil to the fuselage (use a tape that won't damage the paint, such as masking tape).

5. Whatever you do, *do not leave an ELT/EPRIB in the alarm state unless ordered to do so by the IC/AFRCC*. You will have to consult your IC, AFRCC, and/or law enforcement to silence the ELT if the above methods are not practical. Last but not least, ensure the aircraft owner is notified that the ELT was disabled. If you can't obtain a phone number, you can put a sticker on the aircraft (not a window) stating that the ELT has been disabled.
6. AFRCC information. You need to keep a log of the ELT search in order to provide certain information to AFRCC. This information will be given to the Incident Commander, and is required before AFRCC will close out the mission:
- a. Date and time (Zulu) you left on the sortie.
 - b. Date and time the ELT was first heard.
 - c. Time in the search area and time enroute (hours and minutes; Hobbs).
 - d. Area(s) searched.
 - e. Actual location of the ELT, including latitude and longitude.
 - f. Date and time the ELT was located and silenced.
 - g. ELT model, manufacturer, serial number and battery expiration date.
 - h. Position in which you left the ELT switch: On, Off, or Armed.
 - i. Other (not required): 'N' or vessel number, make and model, owner information, and how the ELT was actuated.

7. *Legal issues.* Per CAPR 60-3 Chapter 1, CAP members will not enter private property and should not do anything that could cause harm or damage to the distress beacon or aircraft/boat. If entry is required the owner/operator or local law enforcement officials will make it.

A transmitting ELT is under the legal authority of the FCC, and federal law requires that it be deactivated ASAP. However, CAP members *do not have the authority to trespass onto private property*, either to gain access to the aircraft or to enter the aircraft to gain access to the ELT. You must gain permission from the owner before you enter a private hanger or an aircraft. In some cases, especially at an airport, FBO personnel have permission to enter aircraft on the premises and can assist you.

Normally, local law enforcement officials are happy to assist you. If they are not familiar with CAP and your responsibilities, a simple explanation often suffices. If this doesn't work, try calling AFRCC and have them explain the situation.

That said, when searching under the tasking of the AFRCC, CAP forces are "assisting" the FCC and no one else. If a local law enforcement officer prevents a CAP ground team from going on to an accident scene to deactivate the ELT, the deputy is in the wrong. Now, that does not mean you just shove your way past the deputy. You call your IC, who calls the AFRCC, who calls the Sheriff at home at 3:00 a.m. and explains that the Sheriff really doesn't want to get crosswise with the FCC. The Sheriff is usually only too happy to call the deputy and allow the ground team to enter the scene to deactivate the ELT.

NOTE: A *crashed* aircraft is under the authority of the National Transportation Safety Board (NTSB) *and no one else*. Federal law permits the NTSB to request assistance from federal, state and local agencies (including CAP) to secure a crash site.

Practice

Setup: The student needs a hand-held DF unit, a hand-held radio, and aluminum foil and tape.

First, place a practice beacon in an open location where it is visible to the student. Have the student use the hand-held DF unit and the hand-held radio to locate the beacon.

After the student is comfortable with the DF and radio indications, place the practice beacon in an open location but not visible to the student. Have the student DF to the beacon using both the DF unit and the radio.

Next, place the practice beacon in an area where the signal will be reflected, preferably in an aircraft that is inside a hanger. Have the student locate the beacon using the DF and/or the radio.

Have the student install an aluminum foil 'tent' over an ELT antenna on an aircraft.

Additional Information

More detailed information and figures on this topic are available in Chapter 10 of the MART.

Evaluation Preparation

Setup: Provide the student with a hand-held DF unit, a hand-held radio, a practice beacon, and aluminum foil and tape.

Brief Student: You are a Mission Observer trainee asked to locate and silence an ELT (practice beacon), and discuss the legal issues involved.

Evaluation

<u>Performance measures</u>	<u>Results</u>	
1. Locate a practice beacon in an open area on the ground.	P	F
2. Locate a practice beacon in an aircraft inside a hanger.	P	F
3. Discuss the typical physical location of ELTs in various types of aircraft.	P	F
4. Demonstrate (may simulate) how gain access to and silence an aircraft ELT.	P	F
5. Install an aluminum foil 'tent' over an aircraft's ELT antenna.	P	F
6. List information (required by AFRCC) that you should record during an ELT search.	P	F
7. Discuss the legal issues involved in silencing an ELT.	P	F

Student must receive a pass on all performance measures to qualify in this task. If the individual fails any measure, show what was done wrong and how to do it correctly.

O-2008
COMPLETE A MISSION SORTIE

CONDITIONS

You are a crew member trainee and must demonstrate how to complete a mission sortie.

OBJECTIVES

Obtain general and aircrew briefings with the mission pilot, assist in filling out the front page of a CAPF104, ensure releases are obtained, inventory sortie supplies, and give the scanners their sortie assignments.

Perform or describe mission duties during a sortie, actions upon return to mission base, fill out the remainder of the CAPF104, and perform a sortie debriefing.

TRAINING AND EVALUATION

Training Outline

1. The ability to complete a mission sortie is essential. A well prepared and thorough aircrew will help ensure the success of the mission.

2. *General briefing.* Soon after sufficient data have been assembled, and the mission base is functioning, there will be an initial general mission briefing that everyone must attend. The incident commander (or designee) introduces the staff and covers mission base and safety procedures. The IC then summarizes the situation, including a description of the search objective. A map may be displayed, and the areas to be searched (or the object or area to be assessed) will be outlined on the map. Usually, someone provides a time hack.

Other items covered include current and forecast weather conditions, the communications, flightline, taxi, and safety plans, status boards (for updates), logistics, and supply. You may be handed a sortie packet at this time, or the Briefing Officer may make assignments individually.

Thereafter, the general briefing is normally given each morning (or at the beginning of each operational period). Updates are posted regularly or after a significant development.

3. *Aircrew briefing.* A detailed briefing will be given to each aircrew (and ground team) prior to each sortie. Depending on the circumstances, the mission pilot may receive the briefing or the entire aircrew may be briefed together. It is important that you pay attention and ask questions. In this briefing, there are no stupid questions.

A. During the briefing, ensure you get enough information to fill out the left front of the CAPF 104:

- 1) Objectives and Search Area/Route
- 2) Terrain/Ground cover
- 3) Direction of tracks, track spacing, search altitude and airspeed
- 4) Hazards to flight and military routes (local and search area)
- 5) Aircraft separation
- 6) Weather (local and search area)
- 7) Communications call signs, frequencies and procedures
- 8) Actions to be taken if target sighted
- 9) Estimated time of departure and time enroute
- 10) Inbound and Outbound headings and altitudes
- 11) Whether using Local (preferred) or Zulu time

B. CAPF 104. A CAP flight plan and a sortie briefing form are required for each sortie flown by your aircrew. The front of the CAPF 104 serves both purposes.

MISSION FLIGHT PLAN/BRIEFING FORM		MISSION NO. MAS01-001	DATE 20-Jul-01	SORTIE NO. 1
INSTRUCTIONS: Pilot completes section pertaining to aircraft and crew (items above double line), and then gives form to Briefing Officer. Remaining items will be completed as required prior to flight. Complete reverse side after mission.				
CREW QUALIFICATION		Aircraft Equipment		FLIGHT PLAN INFO
PILOT: Act Type <input checked="" type="checkbox"/> Night <input checked="" type="checkbox"/> Instrument <input checked="" type="checkbox"/> Mountain <input checked="" type="checkbox"/> CO-PILOT: Mission _____ Trainee _____ OBSERVER: Mission <input checked="" type="checkbox"/> Trainee _____ OBSERVER: Mission _____ Trainee <input checked="" type="checkbox"/>		<input checked="" type="checkbox"/> CAP RADIO FREQ <input type="checkbox"/> SIGNAL FLARES <input checked="" type="checkbox"/> POLICE RADIO FREQ <input type="checkbox"/> FLARES <input checked="" type="checkbox"/> VOR <input checked="" type="checkbox"/> MESSAGE DROPS <input checked="" type="checkbox"/> ADF <input checked="" type="checkbox"/> SURVIVAL KIT <input checked="" type="checkbox"/> ELT <input checked="" type="checkbox"/> TRANSPONDER <input checked="" type="checkbox"/> NIGHT FLIGHT <input checked="" type="checkbox"/> DIRECTION FINDER <input checked="" type="checkbox"/> INSTRUMENT FLT <input checked="" type="checkbox"/> GPS <input checked="" type="checkbox"/> FIRE EXTINGUISHER <input type="checkbox"/> <input checked="" type="checkbox"/> FIRST AID KIT		CAP <input checked="" type="checkbox"/> FILED FAA <input type="checkbox"/> IFR <input type="checkbox"/> VFR <input checked="" type="checkbox"/> AIRCRAFT NUMBER <u>N99545</u> AIRCRAFT TYPE <u>C172P</u>
MISSION OBJECTIVES: Details here, such as route, grid, creeping line or expanding square search area.		TRUE AIRSPEED <u>110 KIA</u>		
SEARCH AREA/ROUTE (DESCRIPTION) Describe in sufficient detail that mission base knows exactly where you are going and in what sequence.		POINT OF DEPARTURE <u>BAK</u>		
TERRAIN/GROUND COVER Describe. Use descriptors from reverse		ETD/ATD <u>1300 Z/1310 Z</u>		
TYPE OF SEARCH PATTERN(S) Route, creeping line, etc.		OUTBOUND/INBOUND ALTITUDE <u>2,000 F 2,500 F</u>		
DIRECTION OF TRACKS N/S or E/W		ROUTE OF FLIGHT Flight plan detail of route		
TRACK SPACING 1 nm, 1/2 nm, etc.		SEARCH AIRSPEED 90		
HAZARDS TO FLIGHT Towers, water fowl, parachuting, etc.		DESTINATION AIRPORT <u>BAK</u>		
MILITARY LOW ALTITUDE TRAINING ROUTES VR 1617		CITY <u>Columbus, IN</u>		
AIRCRAFT SEPARATION (ADJOINING AREAS) As applicable		ESTIMATED TIME ENROUTE HRS. <u>1</u> MIN. <u>30</u>		
EMERGENCY FIELDS OVO, SER		FUEL ON BOARD HRS. <u>4</u> MIN. <u>10</u>		
WEATHER CURRENT LOCAL Describe		ALTERNATE AIRPORT <u>SER</u>		
FORECAST LOCAL Describe		PILOT'S NAME <u>Lance Largewatch</u>		
WEATHER CURRENT SEARCH AREA Describe		PILOT'S ADDRESS <u>Roswell New Mexico</u>		
MISSION BASE CALL SIGN Columbus base		FREQUENCIES FM - VHF - HF Channel <u>4</u>		
MOBILE CALL SIGN Ground Team 1		FREQUENCIES FM - VHF Channel <u>1</u>		
MOBILE LOCATIONS North side of Seymour		PILOT'S PHONE NO. <u>Classified</u>		
WHO TO CONTACT AND WHEN Mission base every 30 minutes for Ops Normal		NO. OF PERSONS ABOARD <u>3</u>		
ACTIONS TO BE TAKEN IF SAR OBJECTIVE IS LOCATED Call Ground Team 1 and direct to site		COLOR OF AIRCRAFT <u>W/B/R</u>		
CODE WORDS RECALL <u>ET Phone Home</u> FIND <u>Here it is!</u>		PROPOSED LDG TIME <u>14:30 Z</u>		
PILOT'S SIGNATURE		ACTUAL LDG TIME <u>14:40 Z</u>		
BRIEFING OFFICER'S SIGNATURE		FAA FLT PLAN CLOSED <input type="checkbox"/>		
OPS/CLEARANCE/DISPATCH SIGNATURE				

CAP Form 104 May 84 PREVIOUS EDITION IS OBSOLETE.

CAP Flight Plan

The right side of the front of the CAPF 104 serves as the CAP flight plan. It lists details of your aircraft, your intended route of flight, anticipated flight time, fuel available versus fuel you intend to use (plus reserve), and souls on board -- all meant to let the mission staff know where you are going and when you should return and to facilitate rescue efforts in case of an emergency.

The mission pilot must consider many things as she fills out the flight plan. Since the primary purpose of the plan is to let mission staff know where your aircraft is going and when it will return, the "Route of Flight" is one of the most important blocks on the flight plan: ensure it clearly describes your intentions, including any fuel or rest stops. The "Estimated Time Enroute" is also very important: if a sortie isn't back within a reasonable time past this estimated time of return, mission base will attempt to contact you and a search may be started.

As you plan the sortie, the pilot should consider Inbound/Outbound headings and altitudes; if no altitudes are assigned and you will be flying below 3000' AGL use 'odd' altitudes, such as 1300' or 2300' if the terrain and obstacles allow, in order to avoid normal traffic during your transits.

Once you have planned the route and have a time estimate, add some time to drop down and verify sightings (normally 15 minutes to descend to 500' AGL, circle, and return to 1000' AGL).

Now the pilot should double-check "Estimated Time Enroute" against "Fuel Onboard." If the time enroute exceeds fuel load *minus reserve* (e.g., a "round robin" sortie or extended sortie where you plan to refuel), ensure the "Route of Flight" thoroughly explains your intentions and lists your fuel stop.

CAP Briefing Form

The left side of the front of the CAPF 104 serves as the sortie briefing form. It lists mission objectives, describes the search area or route, defines terrain and ground cover (try to use the terminology from the POD chart on the bottom of the reverse side), gives details of the search pattern to be used, lists hazards to flight, defines current and forecast weather in the search area, and lists other mission details. Be thorough and thoughtful as you fill out this form. It is very important. [If possible, the aircrew should hold an informal group briefing as you complete this form. Crew resource management demands prior agreement on details of the search.]

Your briefing kit should contain:

- 1) CAPF 104 and CAPR 60-1
- 2) Airport diagram, taxi plan/procedures, emergency-landing areas
- 3) Current and Gridded sectionals (if gridded sectionals are not current, mark "Not for Navigation")
- 4) Maps (road atlas, county maps, topo maps)
- 5) Checklists

If flying grids and no aircraft will be in the adjacent grids, plan your turns outside the grid for breaks.

Finally, review your planning aids (marked-up charts and notes) for accuracy and legibility. Also, you should write in your Cap Flight number on the form, in the "Flight Plan Info" section. This helps the communications personnel. Ensure you have the (operable) equipment to accomplish the objective.

After reviewing the plan with the crew, the mission pilot signs the form.

4. *Operational Risk Management (ORM)*. Operational Risk Management (ORM) is a practical way to accomplish the mission with the least possible risk. It is more than just common sense (although plain common sense is very important) and more than just a safety program. It can be used to identify and assess anything that might have a negative impact on a mission. ORM is a method of getting the job done by identifying the areas that present the highest risk, then taking action to eliminate, reduce or control the risks. It can be very flexible and can take from a few seconds to a few hours or days.

The Air Force uses a six-step "building block" approach:

Identify the hazards
Assess the risks
Analyze risk control measures
Make control decisions
Implement risk controls
Supervise and review

Accept no unnecessary risks. Unnecessary risk comes without a commensurate return in terms of real benefits or available opportunities. All CAP missions and our daily routines involve risk. The most logical choices for accomplishing a mission are those that meet all mission requirements with the minimum acceptable risk.

Make risk decisions at the appropriate level. Making risk decisions at the appropriate level establishes clear accountability. Those accountable for the success or failure of the mission *must* be included in the risk decision process. The appropriate level for risk decisions is the one that can allocate the resources to reduce the risk or eliminate the hazard and implement controls. Levels include the incident commander, aircraft or mission commander, ground team leader, or individual responsible for executing the mission or task.

Accept risk when the benefits outweigh the costs. All identified benefits should be compared to all identified costs. The process of weighing risks against opportunities and benefits helps to maximize unit capability. Even high-risk endeavors may be undertaken when there is clear knowledge that the sum of the benefits exceeds the sum of the costs. Balancing costs and benefits may be a subjective process and open to interpretation. Ultimately, the balance may have to be determined by the appropriate decision authority.

Integrate ORM into CAP practices, procedures and planning at all levels. Risks are more easily assessed and managed in the planning stages of an operation (this includes planning for a sortie). Integrating risk management into planning as early as possible provides the decision maker the greatest opportunity to apply ORM principles. Additionally, feedback (lessons learned) must be provided to benefit future missions/activities.

5. *Preparing to leave.* Once you have been briefed and the front of the CAPF 104 is complete and signed, the briefing officer will sign the CAPF 104 and direct the pilot to air operations. Here, the chief or director will inform the crew of any changes and release the flight by signing the CAPF 104.

Now is the time for final preparations for the flight. Check the crew equipment and supplies (e.g., headset, charts, maps, plotter, log, checklists, camera, drinking fluids and snacks) and review flightline rules. The final visit to the restroom is made.

The pilot presents the CAPF 104 to the flightline supervisor for final release, and then begins the aircraft pre-flight. Check the aircraft's mission-related equipment and supplies such as binoculars, charts and maps, flashlights, survival equipment, and airsick bags. All windows should be cleaned, if necessary.

[NOTE: If you are assigned an unfamiliar aircraft (not the one you usually fly), the pilot should perform a *very* thorough preflight. Look at (and touch) all antennas, check the struts carefully, check the tires and brakes carefully, and note any significant scratches and dents. You don't want to be blamed for someone else's mistakes.]

Prior to each flight, the pilot will brief the crew. This briefing will include specific information concerning the aircraft such as how to use the seat belts and shoulder harnesses (both must be used at or below 1000' AGL), emergency exit/egress procedures including the order of emergency egress, the no smoking policy, the fuel management plan, and startup and taxi emergency procedures. Duties for each crewmember during the start up, taxi, takeoff, and transit phases of the flight will be assigned. The pilot should inform you when the "sterile cockpit" rules will be in effect. [When more than one flight is accomplished by the same crew during the day,

subsequent briefings are not required to be so detailed but must, at a minimum, highlight differences and changes from the original briefing.]

During the actual search or assessment, the aircrew must be completely honest with each other concerning their own condition and other factors affecting search effectiveness. If you missed something, or think you saw something, say so. If you have a question, ask. If you spot the target, the most important thing to do is *notify mission base immediately*. The recovery must be started as soon as possible.

The mission pilot must take current flight conditions into consideration (e.g., gross weight, turbulence, and terrain) and perhaps add a margin of safety to the assigned search altitude and airspeed. Log these deviations from the assigned search parameters; when you get back from your sortie you can debrief what you did and why.

A. Transit to the Search Area

- 1) Relax sterile cockpit rules
- 2) Maintain situational awareness
- 3) Double-check navigational settings to be used in the search area
- 4) Review search area terrain and obstacles
- 5) Update in-flight weather and file PIREP
- 6) Review methods to reduce fatigue or combat high altitude effects during the search

B. Approaching the Search Area

- 1) Exterior lights on (maximize your visibility so others can "see and avoid")
- 2) Review search objectives
- 3) Double-check radio, audio panel and navigational settings
- 4) Check navigational equipment against each other (detect abnormalities or failures)
- 5) Pilot stabilizes at search heading, altitude and airspeed (not < V_y) at least two miles out

C. In the Search Area

- 1) Log (time and Hobbs) and report "In the Search Area"
- 2) Enter deviations from assigned search parameters in Observer Log
- 3) Hourly Updates - Altimeter setting (closest source) and fuel assumptions
- 4) Report "Operations Normal" at assigned intervals
- 5) Pilot limits time spent below 800' AGL (no lower than 500' AGL) during daylight
- 6) Pilot maintains at least 2000' AGL during nighttime
- 7) Monitor for crew fatigue and high altitude effects
- 8) If you sight the objective, notify mission base at once
- 9) Log all "negative result" sightings

D. Departing the Search Area

- 1) Log (time and Hobbs) and report "Out of the Search Area"
- 2) Pilot double-checks heading and altitude assigned for transit to next search area or return to base

6. *Return from the sortie.* After a short break you will assemble the crew to complete the CAPF 104 and prepare for debriefing. Any drawings or markings made on charts or maps should be transferred onto the CAPF 104 or attached to it. Make sure everything is clear and legible. [NOTE: *The two most common entries overlooked* when completing the CAP flight plan (front side of the CAPF 104) are "ATD" and "Actual LDG Time."]

MISSION DEBRIEFING FORM									
TYPE OF SEARCH: Visual: <input checked="" type="checkbox"/> Electronic: <input type="checkbox"/>			SEARCH PATTERNS USED: Track Crawl (route)						
SEARCH VISIBILITY: (Distance you can see an auto clearly) 1 NM			SEARCH ALTITUDE: (Above ground) 1000 AGL		SEARCH SPEED: 90 Kts		TRACK SPACING: 0.0 NM		
SECTIONAL GRID: N		N		N		N		N	
SEARCHED: (Lat/Long) W		A B C D		W		A B C D		W	
SEARCHED: Route/ Electronically BAK to SER to to									
TIME OF DAY: 13:10 Z to 14:40 Z			Crew Comments about Effectiveness Exec Good Fair <input checked="" type="checkbox"/> Poor						
OBSERVERS/ SCANNERS: Number 2			Crew Remarks of SAR Effectiveness Route was easy to follow, but haze reduced contrast and washed out colors						
TERRAIN: Flat <input checked="" type="checkbox"/>		Rolling Hills		Rugged Hills		Mtns		TURBULENCE: Light: ___ Mod ___ Heavy ___	
COVER: Open <input checked="" type="checkbox"/>		Moderate ___		Heavy ___		Light Snow ___		Deep Snow ___	
COORDINATES OF SIGHTINGS: (Lat/Long) W		W		W		W		VOR Radials	
FLYING TIME: Enroute. (To/From Grid) 0.4 Hrs			Search Time (In Grid) 1.1 Hrs			Total 1.5 Hrs			
NOTE: If part of a grid was searched, draw area covered below in relation to landmarks. Indicate sightings. No sightings.									
Also use for drawings or sketches, and to list attachments.									

OPEN, FLAT TERRAIN					MODERATE TREE COVER AND/OR HILLY					HEAVY TREE COVER AND OR VERY HILLY					
SEARCH ALTITUDE (AGL)	SEARCH VISIBILITY				SEARCH ALTITUDE (AGL)	SEARCH VISIBILITY				SEARCH ALTITUDE (AGL)	SEARCH VISIBILITY				
Track Spacing	1 mi	2 mi	3 mi	4 mi	Track Spacing	1 mi	2 mi	3 mi	4 mi	Track Spacing	1 mi	2 mi	3 mi	4 mi	
500 Ft	5 mi	35%	60%	75%	75%	5 mi	20%	35%	50%	50%	5 mi	10%	20%	30%	30%
	1.0	20	35	50	50	1.0	10	20	30	30	1.0	5	10	15	15
	1.5	15	25	35	40	1.5	5	15	20	20	1.5	5	5	10	15
	2.0	10	20	30	30	2.0	5	10	15	15	2.0	5	5	10	10
700 Ft	5 mi	40%	60%	75%	80%	5 mi	20%	35%	50%	55%	5 mi	10%	30%	30%	35%
	1.0	20	35	50	55	1.0	10	20	30	35	1.0	5	10	15	20
	1.5	15	25	40	40	1.5	10	15	20	25	1.5	5	5	10	15
	2.0	10	20	30	35	2.0	5	10	15	20	2.0	5	5	10	10
1000 Ft	5 mi	40%	65%	80%	58%	5 mi	25%	40%	55%	60%	5 mi	15%	20%	30%	35%
	1.0	25	40	55	60	1.0	15	20	30	35	1.0	5	10	15	20
	1.5	15	30	40	45	1.5	10	15	20	25	1.5	5	10	10	15
	2.0	15	20	30	35	2.0	5	10	15	20	2.0	5	5	10	10

CAP 104 Reverse

Most of the information required on the reverse of the debriefing form is self-explanatory and serves to emphasize the need to take good notes during the sortie (e.g., the observer log).

The "Time of Day" section requires you to enter the time you were in the search area; this helps debriefers and planners to determine if the weather or the sun's position affected search effectiveness.

The "Flying Time" section requires you to insert transit time [(Enroute (to/from grid))], the time you spent actually searching or assessing [Search Time (in grid)], and the "Total" time. These times are easily determined if you noted your takeoff, in search area, out of search area, and landing times and Hobbs readings in your log.

The total time should correspond to the Hobbs time that is recorded in your aircraft flight log (e.g., a Hobbs time of 2.4 corresponds to 2 hours and 24 minutes).

Two items are of utmost importance -- "Crew Comments about Effectiveness" and "Crew Remarks of SAR Effectiveness":

- a. The first involves a quantitative assessment (excellent, good, fair or poor) of how well you accomplished your mission. Factors affecting search visibility (e.g., visibility, lighting, and sun position) and the crew (e.g., turbulence, fatigue, and how well the pilot covered the area) must be considered. Planners take these comments into consideration when determining POD, so *it is vital that you give the mission staff your honest input!*
- b. The second gives the crew a chance to comment on the effectiveness of the sortie in general. Were north/south tracks appropriate, or would east/west be better? Was one-mile track spacing adequate, or was the terrain so broken that half-mile spacing would be better? Were you at the optimal search altitude? Did the terrain you were briefed to expect match what you saw? Was the sortie too long or too short, and should a rest break have been included in the flight planning? These are just a few of the things that aircrews can comment upon. Planners use this feedback to improve POD, so *it is vital that you give the mission staff your honest input.*

There is a large blank section labeled "NOTE" for you to insert drawings, sketches and other supporting information. If necessary, you can also use this space for additional comments. If you are attaching a drawing or other information to the CAPF 104, state something like "drawing attached" in this space. Be sure to label the attachment so it can be related to the CAPF 104 if it accidentally becomes separated (e.g., mission and sortie number). Rather than leave this section blank, enter "No Sightings."

Finally, make sure all entries and sketches/drawings are clear and legible (doing the form on a computer is preferred).

7. *Aircrew debriefing.* During the briefing everything that is known about the mission was passed along to the air and ground teams. In the debriefing, the reverse is true. Each search team (air and ground) tells how it did its job and what it saw. This type of information is given in detail and is in the form of answers to specific questions asked by the debriefer. The information is then passed on the planning section for analysis, and the information may then be passed on, in turn, to departing search crews. [Note: An aircrew or ground team cannot search and have "negative results". Even if the objective is not located, important information can be obtained, such as weather, turbulence, ground cover, and false clues.]

The debriefer uses the information you filled in on the reverse side of the CAPF 104 as a starting point for the debriefing. For example, more information on search area and weather conditions may be needed, and you should be ready to volunteer your observations. Perhaps you noticed an increase in cloud shadows. Perhaps visibility seemed to deteriorate because of the haze that developed after you arrived in the search area. Perhaps turbulence developed during the last one-third of your grid search. Any number of weather or personal factors could have changed during your sortie. To make the best contribution to the debriefing requires that you remember these changes and be prepared to tell the debriefer about them:

Did you make any changes to the planned search procedure? The debriefer's primary concern is to determine adequate search coverage. If, for example, you diverted frequently to examine clues, there is a good possibility that search coverage was not adequate and that another sortie is justified. If you become excessively tired and rested your eyes frequently, tell the debriefer. Everyone understands the degree of fatigue a scanner can experience. But, frequent rest-eye periods will reduce the level of good scanning coverage, and also could be justification for another sortie.

DEMONSTRATE AIR/GROUND TEAM COORDINATION TECHNIQUES

CONDITIONS

You are a Mission Observer trainee and must demonstrate how to coordinate with ground teams.

OBJECTIVES

Demonstrate and discuss air and ground team coordination plans and techniques.

TRAINING AND EVALUATION

Training Outline

1. As a Mission Observer trainee, the ability to coordinate with ground teams is essential.
2. Naturally, the best means of working with a ground team is to use the radio. The observer and scanner should continuously have their eyes on the ground team; this frees you to fly the aircraft. The observer and/or scanner will work the radio to execute the coordination. The observer will likely also have to be the one who keeps track of where you “left” your target. Sometimes you may be the one using the radio.
 - a. It is important to understand that you have the advantage of perspective; the long-range visibility that is inherent to flying is absent from the ground. You can see over the hills, trees, and other obstacles that are blocking the ground team member's sight, so you may have to explain the situation to the ground pounder in painstaking detail.
 - b. Another perspective problem is time: time seems to pass very slowly while waiting for a ground team, and it is easy to get impatient and leave station prematurely.
 - c. Sometimes the ground team member (non-CAP, of course) may not understand radio jargon, so use plain English. For example, if you wanted a ground team to take a left at the next intersection, what would you say? How about “Ground Team 1, CAP Flight 4239, turn left at the next intersection, over.” Most often the plain English answer is the correct way to say it in radioese, anyway.
3. It is important to brief the mission with the ground team, if possible, and at least agree on communications frequencies and lost-comm procedures, maps/charts to be used by *both* teams, determine what vehicle the ground team is driving (e.g., type, color, and any markings), determine what the ground team members are wearing (highly visible vests are preferred), and a rendezvous point and time window for rendezvous (+/- 15 minutes). One tried-and-true method is to rendezvous at a landmark that both the aircrew and the ground team can *easily* identify. A common rendezvous point is an intersection of prominent roads; these are easily identifiable by both the aircrew and ground team. The rendezvous location should be set up before you leave.
4. Also, ground teams that have a hand-held GPS can radio their latitude and longitude coordinates to you and say, “Come and get me!” If you are unable to loiter over the target and bring the ground team to it, you can simply radio the coordinates to the ground team and let them navigate to it on their own. This is not nearly as efficient, however, as when you lead them to it. Note that two pieces of technology have to be working properly to make this work: 1) both air and ground operators need to be proficient with their GPS units and 2) two-way radio communication must be established and maintained.
5. It is important to plan for a loss of communications during the briefing. The teams should agree on pre-arranged signals such as: stopping the vehicle means lost comm; blinking headlights indicate the message has been received; and operating the flashers means the message hasn't been received.

If communications are lost, you have a limited number of signals that can be given using the aircraft itself, as illustrated below. These signals serve as a standard means to acknowledge receiving and understanding signals from the ground. An "affirmative, I understand" response to a survivor's signal can often be a morale booster, and renew hope for imminent rescue.

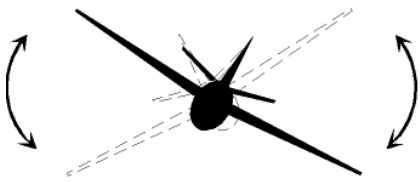

a. Message received and understood

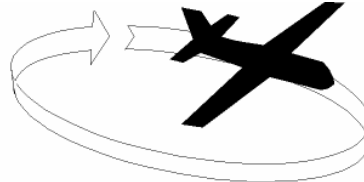

b. Message received but NOT understood



c. Yes or affirmative



d. No or negative

In addition to the four signals shown above, there are two more that you can use to communicate with ground rescue teams. First, if you believe a ground team should investigate an area, you may fly over the team, "race" the engine or engines, and then fly in the direction the team should go. Repeat this maneuver until the ground team responds or until another means of communication is established.

Second, you may pinpoint an area for investigation by circling above the area, continuing to do so until the ground team reaches the area and begins the search. The better the communication from ground-to-air and air-to-ground, the more coordinated the search will be and the greater the chances for success. Below are some patterns you may use to guide a ground team:

Keeping contact with the ground team.

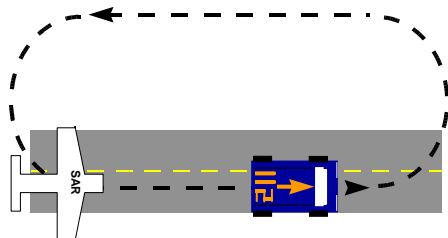

- Aircraft action: Aircraft approaches the vehicle from the rear and turns in a normal manner right (or left) to re-approach the vehicle from the rear. Circle back as necessary using oval patterns and flying over the team from behind, indicating that they should continue. This process may be referred to as a "Daisy Chain." Daisy Chain over the ground team as long as necessary.
- Desired team action: Continue driving in indicated direction along this road.

Turning the ground team around.

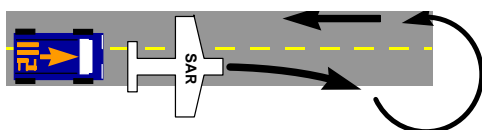

- Aircraft action: Aircraft approaches the vehicle from the rear and then turns sharply right (or left) in front of the vehicle while in motion. Circle back as necessary, flying against the team's direction of travel, and then take up the 'keeping up' procedure outlined above.
- Desired team action: Turn vehicle around.

Turn.

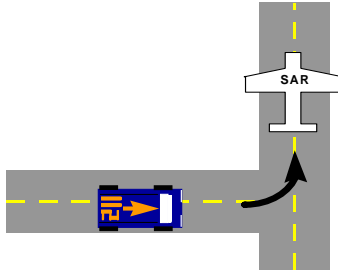

- Aircraft action: Aircraft approaches the vehicle from the rear and then turns sharply right (or left) in front of the vehicle while in motion. Circle back as necessary using oval patterns and flying over the team from behind, indicating that they should continue.
- Desired team action: Turn vehicle to right (or left) at the same spot the aircraft did and then continue in that direction until further signals are received.

Stop or Dismount.

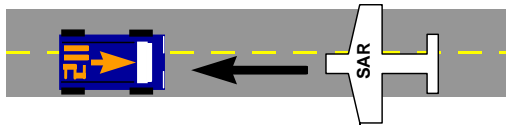

- Aircraft action: Aircraft approaches the vehicle low and head-on while the vehicle is moving.
- Desired team action: Stop the vehicle and await further instructions.
- Aircraft action: Aircraft makes two (or more) passes in same direction over a stopped ground team.
- Desired team action: Get out of the vehicle, then follow the aircraft and obey further signals (proceed on foot).

Objective is here.

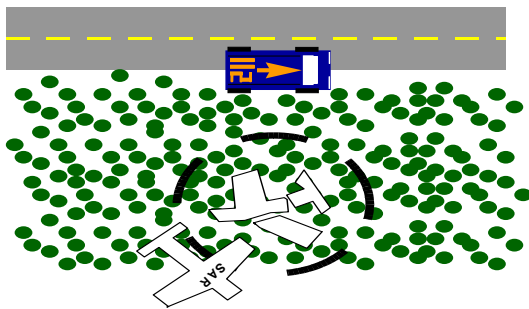

- Aircraft action: Aircraft circles one geographic place.
- Desired team action: Proceed to the location where the low wing of the aircraft is pointing; that is the location of the target.

Additional Information

More detailed information on this topic is available in Chapter 4 and Attachment 2 of the MART.

Evaluation Preparation

Setup: The trainee needs an aircrew and a ground crew.

Brief Student: You are a Mission Observer trainee asked to guide ground units with and without comm.

Evaluation

Performance measures

Results

- | | | |
|---|---|---|
| 1. Discuss crew responsibilities during a combined air/ground team mission. | P | F |
| 2. Discuss factors to consider before you or the ground team leaves mission base. | P | F |
| 3. Demonstrate basic ground team coordination, with and without comm. | P | F |

Student must receive a pass on all performance measures to qualify in this task. If the individual fails any measure, show what was done wrong and how to do it correctly.

O-2010
USE IN-FLIGHT SERVICES

CONDITIONS

You are a Mission Observer trainee and must discuss and use in-flight services.

OBJECTIVES

Discuss and use in-flight services.

TRAINING AND EVALUATION

Training Outline

1. As a Mission Observer trainee, knowing how to obtain in-flight services is very helpful. Observers may use in-flight services in order to reduce pilot workload, and being able to get this information may be very useful during emergencies.

2. *Flight Service Stations*. Provide assistance for preflight and in-flight briefings, scheduled and unscheduled weather broadcasts, and weather advisories. Selected FSSs provide transcribed weather briefings. Enroute weather information can be obtained from the Enroute Flight Advisory Service ("Flight Watch") by tuning 122.0 MHz into the radio and calling "Flight Watch." It mainly provides actual weather and thunderstorms along your route. Additionally, Flight Watch is the focal point for rapid receipt and dissemination of pilot reports (PIREP'S). Other flight service frequencies are indicated on the sectional charts.

3. *Scheduled Weather Broadcasts*. All flight service stations having voice facilities on radio ranges (VOR) or radio beacons (NDB) broadcast weather reports and Notice to Airmen information at 15 minutes past each hour from reporting points within approximately 150 miles of the broadcast station.

4. *Automatic Terminal Information Service (ATIS)*. At many airports, the FAA dedicates one or more transmitters and frequencies to continuous taped broadcasts of weather observations, special instructions, and NOTAMS that relate to the airport or nearby navigational facilities. Broadcast weather information is about *actual* observations for the smaller, terminal area, *not* forecasts. ATIS information is updated *hourly*, but may be updated sooner if the weather, special instructions or NOTAMS change significantly. Usually, you must listen to ATIS recordings on the communication radio (the frequency for the ATIS transmission is found on the sectional chart near the airport's name, or in a table on the reverse side of the sectional title panel).

A typical ATIS transmission may sound like this: "Atlanta Hartsfield Airport, arrival information 'November'. 2350 Zulu weather -- measured ceiling 800 overcast, 1 1/2 miles in fog and haze. Temperature 61 degrees, dew point 60 degrees, wind calm, altimeter 29.80. ILS approaches in progress to Runways 8 Left and 9 Right. Landing runways 8 Left and 9 Right. Atlanta VOR out of service. Taxiway Mike closed between taxiways Delta and Sierra. Read back all 'hold short' instructions. Advise controller on initial contact you have information 'November'."

5. *Hazardous In-Flight Weather Advisory Service (HIWAS)*. You can also receive advisories of hazardous weather on many VORs. As the HIWAS name implies, this information relates only to hazardous weather such as tornadoes, thunderstorms, or high winds. Nav aids having HIWAS broadcast capability are annotated on the sectional chart. When receiving a hazardous weather report, ATC or FSS facilities initiate the taped HIWAS transmissions, and ATC then directs all aircraft to monitor HIWAS.

6. *Automated Weather Observation System (AWOS)*. At many airports, the FAA has installed Automated Weather Observation Systems. Each system consists of sensors, a computer-generated voice capability, and a transmitter. Information provided by AWOS varies depending upon the complexity of the sensors installed. Airports having AWOS are indicated on sectional charts by the letters AWOS adjacent to the airport name.

7. *Automated Surface Observation System (ASOS)*. The primary surface weather observing system in the U.S., the FAA has installed hundreds of ASOS. Each system consists of sensors, a computer-generated voice capability, and a transmitter. Information provided by ASOS varies depending upon the complexity of the sensors installed. ASOS can be heard by telephone, and so is very useful in flight planning. Information includes: wind speed, direction and gusts; visibility and cloud height; temperature and dew point; altimeter setting and density altitude.

8. *Pilot Weather Report (PIREP)*. FAA stations are required to solicit and collect PIREPs whenever ceilings are at or below 5,000 feet above the terrain, visibility is at or less than 5 miles, or thunderstorms, icing, wind shear, or turbulence is either reported or forecast. These are extremely useful reports, and all pilots are encouraged to volunteer reports of cloud tops, upper cloud layers, thunderstorms, ice, turbulence, strong winds, and other significant flight condition information. PIREP's are normally given to Flight Watch. They are then included at the beginning of scheduled weather broadcasts by FAA stations within 150 nautical miles of the area affected by potentially hazardous weather. Pilots are advised of these reports during preflight briefings by FAA and national weather service stations, and by air/ground contacts with FAA stations. PIREP's can help you avoid bad weather and warn you to be ready for potential hazards.

Additional Information

This task may be performed in conjunction with tasks O-2000, O-2001, O-2002. More detailed information on this topic is available in Chapter 4 and Attachment 2 of the MART.

Evaluation Preparation

Setup: Provide the student access to a telephone and an aircraft radio.

Brief Student: You are an Observer trainee asked to use in-flight services.

Evaluation

<u>Performance measures</u>	<u>Results</u>
1. Demonstrate and discuss how to use the following in-flight services:	
a. Flight Service Stations and scheduled weather broadcasts.	P F
b. Obtain an ATIS report.	P F
c. HIWAS.	P F
d. Obtain an AWOS and/or ASOS report.	P F
e. Give a PIREP report (may be simulated).	P F

Student must receive a pass on all performance measures to qualify in this task. If the individual fails any measure, show what was done wrong and how to do it correctly.

O-2011
OPERATE THE VOR AND DME

CONDITIONS

You are an Observer trainee and must use the VOR and DME for navigation and position determination.

OBJECTIVES

Demonstrate how to use the VOR and DME for navigation and position determination.

TRAINING AND EVALUATION

Training Outline

1. As a Mission Observer trainee, knowing how to use nav aids and their limitations is essential for situational awareness. The Very High Frequency Omnidirectional Range (VOR) radio navigation system and Distance Measuring Equipment (DME) allows the aircraft to be flown to a desired location, such as a search pattern entry point, with precision and economy. Once in the search or assessment area, these nav aids allow the pilot to fly the assigned area fairly accurately. From the mission staff's viewpoint, proper use of these nav aids assures them that the assigned area was actually flown -- the only variables left to accommodate are search effectiveness and the inherent limitations of scanning.

One drawback is that setting up and manipulating the VORs and DME may distract the pilot (and observer) from looking outside of the aircraft. The great majority of CAP missions are performed in VFR conditions, and the CAP aircrew must not forget the importance of looking where you're going. The best way to avoid this trap is to become and continue to be very familiar with the operation of the GPS. Training and practice (along with checklists or aids) allows each crewmember to set or adjust instruments with minimum fuss and bother, thus allowing them to return their gaze outside the aircraft where it belongs. All members of the aircrew should be continuously aware of this trap.

Additionally, it is important that observers use this equipment to help the pilot maintain situational awareness. *The observer should always know the aircraft's position on the sectional chart*, and the VOR/DME enables him or her to do so with good accuracy.

2. *ADF*. The Automatic Direction Finder is used to receive radio guidance from stations such as four-course ranges, radio beacons, and commercial broadcast facilities. The automatic direction finder indicates the direction of the station being received shown in relation to the heading of the aircraft: thus, the ADF can be helpful in maintaining situational awareness. The ADF is the least accurate of all the navigational instruments.

3. *VOR*. The Very High Frequency Omnidirectional Range (VOR) radio navigation system transmits 360 directional radio beams or *radials* that, if visible, would resemble the spokes radiating from the hub of a bicycle wheel. Each station is aligned to magnetic north so that the 000 radial points from the station to magnetic north. Every other radial is identified by the magnetic direction to which it points *from* the station, allowing the pilot to navigate directly to or from the station by tracking along the proper radial. The VOR is an accurate and reliable navigational system, and is the current basis for all instrument flight in the U.S. To help light plane pilots plan and chose routings, the FAA has developed the Victor airway system, a "highway" system in the sky that uses specific courses to and from selected VORs. When tracing the route of a missing aircraft, search airplanes may initially fly the same route as the missing plane, so it is very important you know the proper procedures for tracking VOR radials.

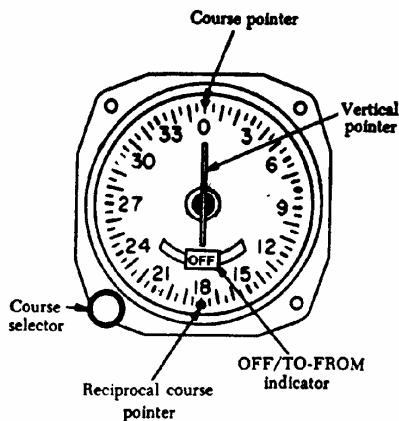

The figure above shows a VOR indicator and the components that give the information needed to navigate, including a vertical pointer, OFF/TO-FROM flag or window, and a course-select knob. The vertical pointer, also called a course deviation indicator (CDI), is a vertically mounted needle that swings left or right showing the airplane's location in relation to the course selected beneath the course pointer. The OFF/TO-FROM indicator shows whether the course selected will take the airplane to or from the station. When it shows “OFF”, the receiver is either not turned on or it’s not receiving signals on the selected frequency. The course selector knob is used to select the desired course to fly either toward or away from the station.

Flying to the VOR station is simple. Find the station’s frequency and its Morse code audio identifier using the sectional chart. Next, tune the receiver to the correct frequency and identify the station by listening to its Morse code (if you can’t positively identify the station, you should not use it for navigation). After identifying the station, slowly turn the course selector knob until the TO-FROM indicator shows TO and the CDI needle is centered. If you look at the course that's selected beneath the course pointer at the top of the indicator, you’ll see the course that will take you directly to the station. The pilot turns the aircraft to match the airplane's heading with that course and corrects for any known winds by adding or subtracting a drift correction factor. The pilot keeps the CDI centered by using very small heading corrections and flies the aircraft directly to the station. When the aircraft passes over the station, the TO-FROM indicator will flip from TO to FROM.

To fly away from a station, tune and identify the VOR, then slowly rotate the course select knob until the CDI is centered with a FROM indication in the window. Look at the selected course, again normally at the top of the indicator, to determine the outbound course. The pilot turns the aircraft to that heading, corrects for wind drift, and keeps the CDI needle in the center to fly directly away from the station.

VORs can be used to determine a position in relation to a selected station. Rotate the course select knob slowly until the CDI is centered with a FROM indication, and look beneath the reciprocal course pointer for the radial. You can draw that radial as a line of position from the station's symbol on the sectional chart. Each VOR station on the chart has a surrounding compass ring already oriented towards magnetic north. Therefore, it isn’t necessary to correct for magnetic variation. The use of the printed compass circle surrounding the station on the chart eliminates the need for using the plotter's protractor as well. Use any straight edge to draw the radial by connecting the station symbol with a pencil line through the appropriate radial along the circle. The radial drawn on the chart shows direction, but does not indicate distance from the station. But, you can get an accurate position “fix” by repeating the procedure with another VOR.

[Note: In order to use a VOR for instrument flight, the receiver must be functionally checked every thirty days (or prior to any instrument flight). This check must be performed by an instrument rated pilot and logged in the aircraft's flight logbook.]

4. *DME*. Finding bearing or direction to a station solves only one piece of the navigation puzzle: knowing the distance to the station is the final piece to the puzzle that allows fliers to navigate more precisely. You can use crossing position lines from two radio stations to obtain your distance from the stations, but an easier method is provided by Distance Measuring Equipment. DME continuously measures the distance of the aircraft from a DME ground unit that is usually co-located with the VOR transmitter (then called a VORTAC). The system consists of a ground-based receiver/transmitter combination called a transponder, and an airborne component called an interrogator. The interrogator emits a pulse or signal, which is received by the ground-based transponder. The transponder then transmits a reply signal to the interrogator. The aircraft's DME equipment measures the elapsed time between the transmission of the interrogator's signal and the reception of the transponder's reply and converts that time measurement into a distance. This measurement is the actual, straight-line distance from the ground unit to the aircraft, and is called *slant range*. This distance is continuously displayed, typically in miles and tenths of miles, on a dial or digital indicator on the instrument panel. When DME is used in combination with VOR, you can tell at a glance the direction and distance to a tuned station.

DME measures straight-line distance, or slant range, so *there is always an altitude component within the displayed distance*. If you fly toward a station at an altitude of 6,000 feet over the station elevation, the DME will never read zero. It will continuously decrease until it stops at one mile. That mile represents the aircraft's altitude above the station. The distance readout will then begin to increase on the other side of the station. Under most circumstances the altitude component of slant range can be ignored, but when reporting position using DME, especially to air traffic controllers, it is customary to report distances in "DME", not nautical miles, e.g., "Holly Springs 099° radial at 76 DME." [Some DME equipment can also compute and display the actual ground speed of the aircraft, provided that the aircraft is flying *directly* to or from the ground station. In all other circumstances, the ground speed information is not accurate and should be ignored.]

Additional Information

The GPS is covered in Task O-2012, and may be performed concurrently with this task. More detailed information on this topic and examples are available in Chapter 8 of the MART.

Evaluation Preparation

Setup: Provide the student access to an aircraft or simulator.

Brief Student: You are an Observer trainee asked to determine aircraft position with the VOR and DME.

Evaluation

<u>Performance measures</u>	<u>Results</u>
1. Use (or discuss) the ADF to determine approximate position.	P F
2. Determine aircraft position with the VOR, and discuss how to use the VOR to fly to/from a station. Also determine position by cross-radials.	P F
3. Determine aircraft position with the DME, and discuss the limitations of DME.	P F
4. Discuss the limitations of each navaid.	P F

Student must receive a pass on all performance measures to qualify in this task. If the individual fails any measure, show what was done wrong and how to do it correctly.

O-2012
OPERATE THE GLOBAL POSITIONING SYSTEM

CONDITIONS

You are an Observer trainee and must use the GPS for navigation and position determination.

OBJECTIVES

Demonstrate how to use the GPS for navigation and position determination.

TRAINING AND EVALUATION

Training Outline

1. As a Mission Observer trainee, knowing how to use the GPS and its limitations is essential. The Global Positioning System (GPS) allows the aircraft to be flown to a desired location, such as a search pattern entry point, with precision and economy. Once in the search or assessment area, the GPS allows the pilot to fly the assigned area precisely and thoroughly. From the mission staff's viewpoint, proper use of the GPS assures them that the assigned area was actually flown -- the only variables left to accommodate are search effectiveness and the inherent limitations of scanning.

One drawback is that setting up and manipulating the GPS may distract the pilot (and observer) from looking outside of the aircraft. The great majority of CAP missions are performed in VFR conditions, and the CAP aircrew must not forget the importance of looking where you're going. The best way to avoid this trap is to become and continue to be very familiar with the operation of the GPS. Training and practice (along with checklists or aids) allows each crewmember to set or adjust instruments with minimum fuss and bother, thus allowing them to return their gaze outside the aircraft where it belongs. All members of the aircrew should be continuously aware of this trap.

Additionally, it is important that observers use this equipment to help the pilot maintain situational awareness. *The observer should always know the aircraft's position on the sectional chart*, and the GPS enables him or her to do so with great accuracy.

2. The Global Positioning System relies on a chain of 24 satellite transmitters in polar orbits about the earth. The speed and direction of each satellite, as well as each satellite's altitude is precisely maintained so that each satellite remains in a highly accurate and predictable path over the earth's surface at all times. The GPS receiver in the aircraft processes signals transmitted by these satellites and triangulates the receiver's position, which the user again can read directly in latitude and longitude coordinates from a digital display. The system is substantially more accurate than LORAN, VOR, DME, or ADF and has several advantages.

Because the transmitters are satellite (not ground) based, and the signals are essentially transmitted *downward*, system accuracy is not significantly degraded in mountainous terrain. Additionally, the system is not normally vulnerable to interference from weather or electrical storms. Receivers can typically process as many as twelve received signals simultaneously, and can automatically deselect any satellite whose signal doesn't meet specific reception parameters. The system can function with reasonable accuracy using as few as three received signals.

3. To a new operator, the GPS is complex and can initially increase the user's workload. Pilots and observers *must read the operating manual or instructions* and become thoroughly familiar with GPS operation before flight, so that operating the GPS *will not become a distraction* from more important tasks. Also, many manufacturers have CD simulators (e.g., U.S. Aviation Technologies' Apollo GX55; www.upsat.com) that allow individuals to practice use of the GPS on a computer.

4. CAP is standardizing the fleet with the Apollo GX55 (below). Even if your aircraft has a different GPS, the basic functions are the same.



All GPS units display bearing and distance to waypoints (i.e., airports, VORs, intersections, and user waypoints); position can also be determined by displaying current lat/long coordinates. For emergency use, all GPS units have a feature that allows you quickly and easily display bearing and distance to the nearest airports or VORs (often a list of the ten nearest facilities).

The GPS displays altitude, ground speed, estimated time to the waypoint (ETE), and ground track. GPS databases also contain extensive information about selected waypoints (e.g., an airport) such as runway length and alignment, lighting, approaches, frequencies, and even FBO details such as the availability of 100LL fuel and hours of operation.

The GPS receiver also allows pilots to:

Fly directly to any position

The ability to fly directly to any position (e.g., an airport, navaid, intersection, or user waypoint) saves time and fuel. This reduces transit time, thus allowing more of the crew's allowed duty day to be spent in the search area. Any of these positions can be entered as the destination through a simple procedure. Additionally, all GPS have a "Nearest Airport" and "Nearest VOR" function, where you can easily display a list of the nearest airports or VORs and then select it as your destination. Positions can also be grouped into flight plans. Once the destination is entered into the GPS, the heading and the ground track can be monitored. *By matching the heading and ground track (or keeping the CDI centered), you are automatically compensating for wind and thus flying the shortest possible route to your destination.*

Fly between any two points

The ability to fly directly between any two points greatly improves search effectiveness. These points, usually defined by latitude and longitude (lat/long), can be flown in either of two ways:

- The points can be entered into the GPS as user-defined waypoints. The waypoints can then be recalled in the same manner as you would display an airport or navaid, or they can be entered into a flight plan.
- The pilot can fly between the points by observing the current lat/long display (i.e., a real-time readout of latitude and longitude).

5. Two factors have reduced search effectiveness in the past: drifting off course due to shifts in wind direction, and drifting off course because of the lack of adequate boundaries (e.g., cross-radials or visible landmarks). Now any search pattern can be flown precisely without relying on cross-radials or ground references. The crew and the mission staff know that a route or area has been covered thoroughly. Also, GPS allows the crew to remain within assigned boundaries, which greatly improves safety when more than one aircraft is in the search area at the same time.

NOTE: The Apollo GX55 has a "moving map," which greatly enhances situational awareness. It shows aeronautical and ground features in (scalable) detail, and also displays special use airspace. Another feature, added to the unit for CAP use, is the SAR MAP mode. This feature allows you to select, define and fly directly to a CAP grid, and to superimpose a search pattern on the grid (e.g., parallel, creeping line or expanding square). The SAR features will be covered in another task guide.

Additional Information

The VOR/DME is covered in task O-2011, and may be performed concurrently with this task. More detailed information on this topic and examples are available in Chapter 8 and Attachment 2 of the MART.

Evaluation Preparation

Setup: Provide the student access to an aircraft or a GPS simulator.

Brief Student: You are an Observer trainee asked to determine aircraft position with the GPS.

Evaluation

<u>Performance measures</u>	<u>Results</u>
1. Using the operator's manual, discuss the operation of the GPS.	P F
2. Using the operator's manual, display information provided by the GPS:	
a. Altitude.	P F
b. Ground speed.	P F
c. Heading to waypoint and current heading.	P F
d. Track over ground (ground track).	P F
e. Estimated time to the waypoint (ETE).	P F
3. Using the operator's manual, determine current position using:	
a. Bearing and distance to waypoints.	P F
b. Present position (lat/long coordinates).	P F
c. Moving map display (if applicable).	P F
4. Using the operator's manual, enter a destination waypoint:	
a. Airport.	P F
b. VOR.	P F
c. User-defined (lat/long coordinates).	P F
5. Using the operator's manual, display "nearest airport" and "nearest VOR."	P F

Student must receive a pass on all performance measures to qualify in this task. If the individual fails any measure, show what was done wrong and how to do it correctly.

O-2013
PLOT A ROUTE ON A SECTIONAL CHART

CONDITIONS

You are an Observer trainee and must plot a simple route on a sectional chart.

OBJECTIVES

Plot a course on a sectional chart, select checkpoints along a route, and calculate how long it will take to fly the route.

TRAINING AND EVALUATION

Training Outline

1. As a Mission Observer trainee, knowing how to plot a route on a sectional chart is essential in order to assist the pilot, and help maintain situational awareness.
2. Plot the course. To determine a heading, locate the departure and destination points on the chart and lay the edge of a special protractor, or *plotter*, along a line connecting the two points. Use a marker to trace the route. Read the true course for this leg by sliding the plotter left or right until the center point, or grommet, sits on top of a line of longitude. When the course is more to the north or south, you can measure it by centering the grommet on a parallel of latitude, then reading the course from the inner scale that's closer to the grommet.
3. Distance. To determine the distance you're going to travel, lay the plotter on the route and read the distance using the scale that's printed on the plotter's straight edge: one edge measures nautical miles and the other statute miles.
4. Flight time. To determine the time it will take to fly between any two points, divide the distance (in nm) by the proposed airspeed (in knots).
5. Checkpoints. There are a number of ways you can add information to your chart that will help during the flight. Tick marks along the course line at specific intervals will help you keep track of your position during flight (situational awareness). Some individuals prefer five- or ten-nautical mile (nm) intervals for tick marks, while others prefer two- or four-nm intervals. Four-nautical mile spacing works well for aircraft that operate at approximately 120 knots. Since the 120-knot airplane travels 2 nm every minute, each 4 nm tick mark represents approximately two minutes of flight time. On the left side of the course line you have more tick marks, at five-nm intervals, but measured backward from the destination. In flight, these continuously indicate distance remaining to the destination, and you can easily translate that into the time left to your destination.

The next step in preparing the chart is to identify *checkpoints* along the course; you can use these to check your position on- or off-course, and the timing along the leg. Prominent features that will be easily seen from the air make the best checkpoints, and many like to circle them or highlight them with a marker in advance. You should select easy (large) targets such as tall towers, cities and towns, major roads and railroads, and significant topological features such as lakes and rivers. Try not to select checkpoints that are too close together. During a mission, checkpoint spacing will be controlled by the search altitude and weather conditions and visibility at the time of the flight.

Additional Information

More detailed information on this topic is available in Chapter 8 of the MART.

Evaluation Preparation

Setup: Provide the student with a sectional chart and a plotter. Give the student two points on the chart.

Brief Student: You are an Observer trainee asked to plot a course, select checkpoints along the route, and calculate time in flight.

Evaluation

Performance measures

Results

Given a sectional chart, a plotter, and two points on the chart (e.g., two airports):

- | | | |
|---|---|---|
| 1. Plot a course between the two points. | P | F |
| 2. Select checkpoints along the route. Discuss the reason you selected the checkpoints. | P | F |
| 3. Calculate the time it will take an aircraft (120 knots with no wind) to fly the route. | P | F |

Student must receive a pass on all performance measures to qualify in this task. If the individual fails any measure, show what was done wrong and how to do it correctly.

O-2015
DEMONSTRATE GROUND OPERATIONS AND SAFETY

CONDITIONS

You are a Mission Scanner trainee and must demonstrate safety around an aircraft on the ground.

OBJECTIVES

Demonstrate ramp safety, moving and loading aircraft, entry/egress, and basic fuel management.

TRAINING AND EVALUATION

Training Outline

1. As a Mission Scanner trainee, knowledge of aircraft ground operations and safety is essential.
2. Ramp safety:
 - a. Don't wear headgear, don't run, and always look out for moving aircraft and spinning propellers.
 - b. No smoking within 50 feet of aircraft or fuel trucks/tanks.
 - c. Keep clear of aircraft, especially the propeller or turbines. A propeller spins at over 2000 rpm, so you may not be able to see it. If you see an aircraft sitting on the ramp with a rotating beacon or strobe light on, the pilot may be about to start the engine. Also, the trailing edges of the wings, flaps and ailerons may be sharp and are often at head level.
 - d. In case of a fire on the ground, get clear of the aircraft. Know where the nearest large fire extinguisher is. But, if fuel is spilling and it isn't necessary to help people clear of the fire, get away and call the fire department.
3. Moving aircraft. Never push or pull an aircraft without a pilot being present, and don't rotate, hold or move a propeller. Never push or stand on any part of the aircraft labeled "No Push."
4. Loading aircraft. Ensure all loose items are stowed and secured (e.g., under the cargo net). Loose objects can become projectiles during turbulence, hurting occupants or damaging equipment. Also, if you are about to load something that wasn't discussed prior to the flight (e.g., during the weight and balance calculations), tell the pilot.
5. Entry and egress:
 - a. Be careful where you step. Watch for "No Step" or "No Handhold" placards.
 - b. As a rule, never enter or exit an aircraft while the engine is running. If you must, always ensure the pilot knows your intentions and approach from the rear.
 - c. Always wear your seatbelt and shoulder harness. Once above 1000 AGL you may remove your shoulder harness, but it's a good idea to keep it on unless performing an activity such as aerial imaging.
 - d. Part of every pre-flight should include a briefing on emergency egress in order to avoid confusion. Crewmembers will remove their headsets. In most CAP aircraft, the pilot will leave his seat full forward so those in the back seat can exit out the left door. The pilot will then follow the observer out the right door.

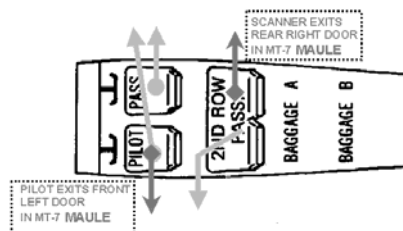

6. Fuel management. The pilot is responsible for ensuring enough fuel is available to complete the flight safely with sufficient reserves left for diversions or emergencies. She should brief you on the fuel situation before the flight, including her assumptions on how much fuel will be needed (usually expressed in hours and minutes) and where you will refuel if necessary. Fuel status should be checked once an hour. Never feel hesitant to ask about your fuel status.

Additional Information

More detailed information on this topic is available in Chapter 2 of the MART.

Evaluation Preparation

Setup: The evaluation should be conducted with an aircraft on the ramp, with a PIC present.

Brief Student: You are a Scanner trainee asked about safety around aircraft on the ground.

Evaluation

<u>Performance measures</u>	<u>Results</u>	
1. Discuss ramp safety.	P	F
2. Demonstrate moving and loading an aircraft.	P	F
3. Demonstrate entry and emergency egress from all seats in the aircraft.	P	F
4. Discuss the scanner's role in basic fuel management.	P	F

Student must receive a pass on all performance measures to qualify in this task. If the individual fails any measure, show what was done wrong and how to do it correctly.

O-2016
DEMONSTRATE SAFETY WHILE TAXIING

CONDITIONS

You are a Mission Scanner trainee and must demonstrate safety techniques while taxiing in an aircraft.

OBJECTIVES

Demonstrate safety while taxiing, including airport signs and markings and flightline hand signals.

TRAINING AND EVALUATION

Training Outline

1. As a Mission Scanner trainee, knowledge of safety during taxiing is essential. *All crewmembers should assist the pilot while taxiing.* The pilot should brief each crewmember on what direction he or she should look out the aircraft. Sterile cockpit rules are in effect, so the crew should limit their conversation to the task at hand. Report conflicts to the pilot immediately, using the "clock position" method.

- a. Maintain adequate clearance from obstacles.
- b. When taxiing within 10 feet of obstacles stop, and then proceed no faster than a slow walk.
- c. If available, use marshallers or a "wing walker."
- d. Potential collisions with other aircraft or vehicles.
- e. Stay on or find the taxiway. At night or under low visibility conditions, assist the pilot. Some smaller airports do not mark their taxiways or the paint may be faded.

2. Runway markings are white and taxiways are yellow. Taxiway centerlines are solid yellow. Some taxiway boundaries are marked with double yellow lines while others have blue lights or cones.

3. Mandatory signs have a red background with a white inscription, and are used to denote an entrance to a runway or critical area where an aircraft is prohibited from entering without ATC permission:

- a. Holding position for a runway. Do not cross without ATC permission.
May have a row of red stop bar lights, embedded in the pavement and extending across the taxiway at the runway holding position. When illuminated they designate a runway hold position: never cross a red illuminated stop bar, even if cleared by ATC.
- b. Holding position for approach area. Do not cross without ATC permission.
- c. Holding position for instrument landing system. Do not cross without ATC permission.
- d. No entry. Typically placed on a one-way taxiway or at the intersection of vehicle roadways that can be mistaken for a taxiway.

15-33

15-APCH

ILS



4. Holding position marking for runway boundary. Four yellow lines: two solid and two dashed. The aircraft approaches the dashed lines and stops behind the solid lines (ensures you do not enter the runway). Do not cross without ATC permission. When exiting the runway, the pilot should cross the dashed lines to make sure the aircraft is completely clear of the runway.

May have yellow clearance bar lights embedded in the pavement to indicate a hold point. May have flashing yellow guard lights elevated or in-pavement at runway holding positions.



5. Location signs are used to identify either a taxiway (letters) or runway (numbers) on which an aircraft is located, or to provide a visual clue to the aircrew when the aircraft has exited an area:



6. Direction signs give a yellow background with a black inscription.



7. Ground crew use hand signals to help direct pilots during taxi operations. The scanner should be familiar with these signals in order to increase safety during taxiing and parking:

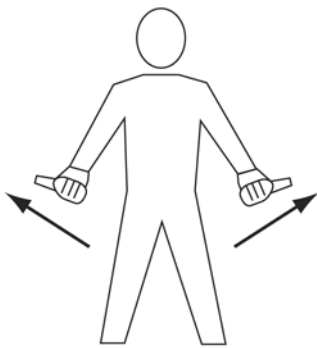

Outward motion with thumbs.
PULL CHOCKS



Circular motion of right hand at head level with left arm pointing to engine.
START ENGINE



Raise arm, with fist clenched, horizontally in front of body, and then extend fingers.
RELEASE BRAKE



Thumb Up.
OK or YES



Thumb Down.
NOT OK or NO



Arms above head in vertical position with palms facing inward. **THIS MARSHALLER**

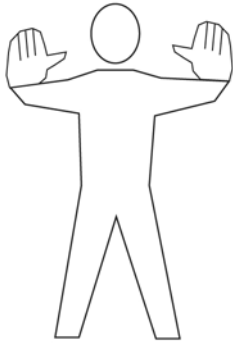

Arms a little aside, palms facing backwards and repeatedly moved upward and backward from shoulder height. **MOVE AHEAD**

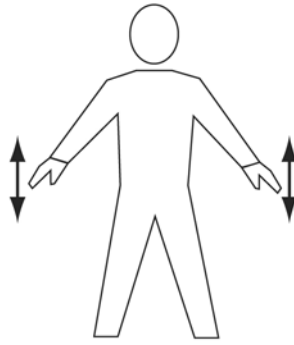

Arms down with palms toward ground, then moved up and down several times. **SLOW DOWN**

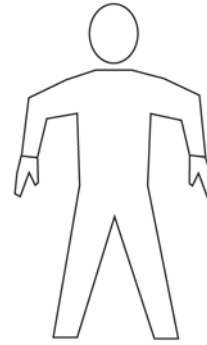

Arms extended with forearm perpendicular to ground. Palms facing body. **HOT BRAKES**



Arms extended with forearm perpendicular to ground. Palms facing body. Gesture indicates right side. **HOT BRAKES - RIGHT**

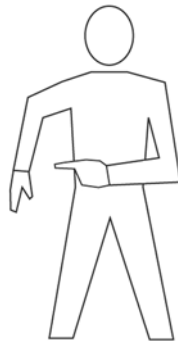

Arms extended with forearm perpendicular to ground. Palms facing body. Gesture indicates left side. **HOT BRAKES - LEFT**



Waiving arms over head. **EMERGENCY STOP**



Right or left arm down, other arm moved across the body and extended to indicate direction of next marshaller. **PROCEED TO NEXT MARSHALLER**

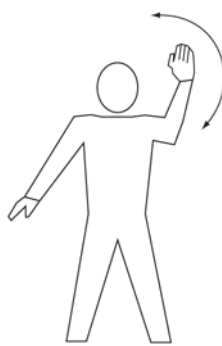

Point right arm downward, left arm repeatedly moved upward-backward. Speed of arm movement indicating rate of turn. **TURN TO THE LEFT**



Point left arm downward, right arm repeatedly moved upward-backward. Speed of arm movement indicating rate of turn. **TURN TO THE RIGHT**



Arms crossed above the head, palms facing forward. **STOP**

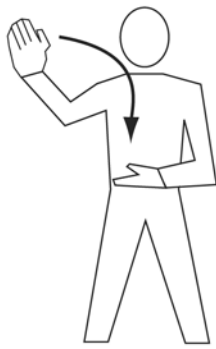

Make a chopping motion with one hand slicing into the flat and open palm of the other hand. Number of fingers extended on left hand indicates affected engine.
FEATHER / FUEL SHUT-OFF

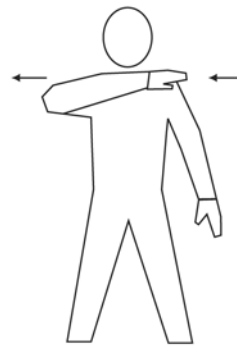

Either arm and hand level with shoulder, hand moving across throat, palm downward.
CUT ENGINES

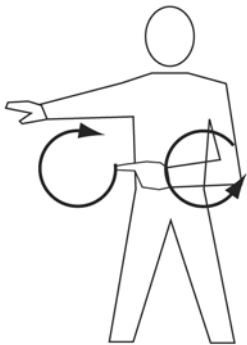

Make rapid horizontal figure-eight motion at waist level with either arm, pointing at source of fire with the other.
FIRE ONBOARD



Raise arm and hand, with fingers extended horizontally in front of the body, then clench fist.
ENGAGE BRAKE

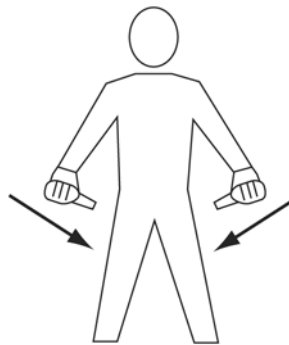

Inward motion with thumbs.
INSERT CHOCKS



Right arm raised with elbow at shoulder height with palm facing forward.
MARSHALLER

Additional Information

More detailed information on this topic is available in Chapter 2 and Attachment 2 of the MART.

Evaluation Preparation

Setup: Provide the trainee access to airport signs and markings (pictures may be used) and someone to give flightline hand signals.

Brief Student: You are a Scanner trainee asked about safety during taxiing.

Evaluation

<u>Performance measures</u>	<u>Results</u>	
1. Discuss the safety rules used to avoid obstacles during taxiing.	P	F
2. Discuss the sterile cockpit rules and how you would point out an obstacle.	P	F
3. State the difference between runway and taxiway markings.	P	F
4. Identify mandatory signs and discuss their meaning.	P	F
5. Identify holding position markings and discuss their meaning.	P	F
6. Identify location and direction signs and discuss their meaning.	P	F
7. Recognize flightline hand signals.	P	F

Student must receive a pass on all performance measures to qualify in this task. If the individual fails any measure, show what was done wrong and how to do it correctly.

O-2017
DISCUSS POST-CRASH ACTIONS

CONDITIONS

You are a Mission Scanner trainee and must discuss basic post-crash actions, and discuss survival equipment and urgent care.

OBJECTIVES

Discuss basic post-crash actions, identify and discuss survival equipment and urgent care.

TRAINING AND EVALUATION

Training Outline

1. As a Mission Scanner trainee, knowledge of basic survival techniques and urgent care is essential.
2. In the event of an off field landing, the crew will follow aircraft emergency procedures prior to the landing.
 - a. The pilot will review emergency egress procedures, the observer (right seat) will prop open the right door (headsets work nicely), and all crewmembers will tighten their seatbelts and shoulder harnesses. If the doors become jammed after the landing, kick them open or exit through the windows.
 - b. Afterwards, get clear of the aircraft if there is any danger (e.g., a fire). Check everyone for injuries and, as a precaution, sip some water to prevent shock.
3. Once the immediate danger is past, turn your attention to rescue. Hopefully the pilot or observer was able to communicate your position. In any case don't become impatient and leave the site, *as your best chance of discovery is to stay near the aircraft*. If rescue isn't expected shortly turn your attention to water, shelter and food (in that order). Remember, **your will to survive is your greatest asset**.
4. Survival. Water is your most important survival resource; always carry some with you plus a means to purify water (if water is available in the terrain you're flying over). Signaling equipment is also essential. For daytime use, nothing outperforms a signal mirror; at night a beacon or strobe works best. Handheld radios and personal ELTs are also very helpful. If you have no signaling device and you need to improvise, remember the "CLASS" acronym:
 - a. Color: make it an unnatural or highly contrasting one (not some color seen in your terrain).
 - b. Location: put it where it can be seen most easily, usually high and in open areas.
 - c. Angles: use angles not found in your terrain.
 - d. Size: make it large, at least 12 feet in height.
 - e. Shape: make it eye-catching.
5. Survival equipment. Know what is in your aircraft's survival kit. As a minimum it should include:
 - a. Water or a means of purifying water.
 - b. Signal mirror and a strobe light.
 - c. Space blankets for each crewmember.
 - d. Rations (e.g., MREs).
 - e. First aid kit and manual.
 - f. Survival manual (matched to your terrain).
 - g. Matches or fire starter.
 - h. Compass.
 - i. Knife.

6. It is also a good idea to carry a personal survival kit, particularly if you routinely fly over difficult or desolate terrain. Some items are:

- a. Multi-function tool such as a *Leatherman*.
- b. Matches or fire starter.
- c. Pocket compass.
- d. Plastic or metal container.
- e. Sewing needles and thread.
- f. Chapstick and sun block.
- g. Bar surgical soap (or soap containing *physohex*).
- h. A small shelter.
- i. Personal medicine(s).
- j. Nice to have items are:
 - 1) Hand held radio
 - 2) Portable GPS
 - 3) Personal ELT
 - 4) Plastic water bottle
 - 5) Aluminum foil

7. Urgent care. The only type of medical aid that should be administered is reasonable urgent care deemed necessary to save a life or prevent human suffering. However, if you are prepared to help others you will be better prepared to care for yourself. Urgent care courses are readily available so take advantage of them. Always limit your actions to those for which you have been trained. That said, the following are four important measures to take in the event of injury:

- a. Do not move an injured person unless it is absolutely necessary to save their life (e.g., fire, smoke or noxious fumes, falling, or flooding).
- b. Ensure the victim has an open airway and give mouth-to-mouth respiration if necessary.
- c. Check for a pulse and perform CPR if necessary.
- d. Locate and control severe bleeding.

8. Once urgent care has been administered, the following can be done:

- a. Do not move an injured person unless it is absolutely necessary.
- b. Do not let the victim get up and move around.
- c. Protect the victim from unnecessary manipulation and disturbance.
- d. Avoid or overcome chilling by using blankets or cover.
- e. Determine all injuries and administer care.
- f. Plan actions according to the nature of the injuries, the needs of the situation, and the availability of human and material resources.

Additional Information

Some more information on this topic is available in Chapter 3 of the MART.

Evaluation Preparation

Setup: Provide the student access to an aircraft with survival gear.

Brief Student: You are a Scanner trainee asked about post-crash actions, basic survival and urgent care.

Evaluation

Performance measures

Results

- | | | |
|--|---|---|
| 1. Discuss actions to take before and immediately after an off field landing. | P | F |
| 2. Identify and discuss basic survival techniques and equipment. | P | F |
| 3. Discuss basic urgent care, including four important measures for treating injuries. | P | F |

Student must receive a pass on all performance measures to qualify in this task. If the individual fails any measure, show what was done wrong and how to do it correctly.

O-2018
OPERATE THE AIRCRAFT COMMUNICATIONS EQUIPMENT

CONDITIONS

You are a Mission Scanner trainee and must operate and discuss the aircraft communications equipment.

OBJECTIVES

Demonstrate basic knowledge and use of the aircraft communications radios and the CAP FM radio.
Demonstrate how to set up the audio panel to use the radios.

TRAINING AND EVALUATION

Training Outline

1. As a Mission Scanner trainee, basic knowledge of aircraft communications equipment is essential. Although you will probably only use the FM radio during missions, knowledge of how to use the other communications equipment could prove very important during emergencies.
2. Aircraft radios. The radios used in CAP aircraft are normally combined with navigation receivers, and so are often referred to as "nav/comm" radios. Each radio (there are usually two) has a 'primary' and a 'standby' function (called "flip-flop"): the primary frequency is displayed on the left and the standby frequency on the right. To use a frequency it must be in the primary display; to change a frequency, it must be in the standby display. The frequencies are normally tuned in increments of 50 kilocycles, for example 119.70 or 119.75 (the last '0' is not displayed). They can also be tuned in increments of 25 kilocycles by pulling out on the tuning knob and turning, but the last '5' will not be shown in the display (e.g., 119.775 will be displayed as 119.77). Sometimes, for brevity, air traffic controllers assign such frequencies as "one-one nine point seven seven," meaning 119.775, not 119.770. The operator cannot physically tune the radio to 119.770, and this may be confusing.



3. Before transmitting on any radio, first *listen* to the selected frequency. An untimely transmission can "step on" another transmission from either another airplane or ground facility, so that *all* the transmissions are garbled. Next, mentally prepare your message so that the transmission flows naturally without unnecessary pauses and breaks (think "Who, Where and What"). You may even find it helpful to jot down what you want to say before beginning the transmission. When you first begin using the radio, you may find abbreviated notes to be a convenient means of collecting thoughts with the proper terminology. As your experience level grows, you may find it no longer necessary to prepare using written notes.
4. CAP aircraft callsigns are pronounced "Cap Flight XX XX," where the numbers are those assigned to each Wing's aircraft. *The numbers are stated in 'group' form.* For example, the C172 assigned to Amarillo, Texas is numbered 4239, where 42 is the prefix identifying it as a Texas Wing aircraft. The callsign is thus pronounced "Cap Flight Forty-Two Thirty-Nine." It is important to use the group form of pronunciation because FAA air traffic controllers expect it of us.
5. CAP VHF FM radio. This radio is dedicated to air to ground communications, and is normally operated by the observer or scanner. Several of the frequencies programmed into the radio are frequencies assigned to CAP by the U.S. Air Force, and are used to communicate with CAP bases and ground teams. Others are

programmed at the direction of the Wing Communications Officer (e.g., mutual aid, fire, police, park service, forest service, and department of public service); these frequencies almost always require prior permission from the controlling agency before use.

There are currently three types of FM radios in use in the CAP fleet at this time. Refer to your aircraft's operating manual for specific details for its use. Chapter 4 of the *Mission Aircrew Reference Text* provides directions on the use of the TDFM-136.

6. Audio panel. The audio panel serves as the 'hub' of radio communications in the aircraft, and is normally set up by the pilot or observer. The scanner needs to know how to select the 'active' aircraft communications radio for transmission. The active radio is selected with the switch on the right-hand side of the panel. Select either COM 1 or COM 2 to transmit and receive on the frequency displayed in the associated radio's primary display.



Additional Information

More detailed information on this topic is available in Chapter 4 of the MART.

Evaluation Preparation

Setup: Provide the student access to aircraft radios or detailed figures.

Brief Student: You are a Scanner trainee asked about using the aircraft radios.

Evaluation

<u>Performance measures</u>	<u>Results</u>
1. Demonstrate how to enter a frequency and use the aircraft communications radios.	P F
2. Discuss the importance of listening before transmitting, and basic message format.	P F
3. Demonstrate proper use of the CAP aircraft callsign.	P F
4. Demonstrate how to select a frequency and use the CAP FM radio.	P F
5. Demonstrate setting up the audio panel to transmit on an aircraft radio.	P F

Student must receive a pass on all performance measures to qualify in this task. If the individual fails any measure, show what was done wrong and how to do it correctly.

O-2019
USE PROPER NUMBER AND CHARACTER PRONUNCIATION

CONDITIONS

You are a Mission Scanner trainee and must demonstrate proper pronunciation of numbers and characters when talking on the radios.

OBJECTIVES

Demonstrate proper pronunciation of numbers and characters when talking on the radios.

TRAINING AND EVALUATION

Training Outline

1. As a Mission Scanner trainee, knowledge of proper number and character pronunciation is essential for communicating on the radios.
2. Numbers. The table shows how to pronounce numbers over the radio:

Number	Pronounced	Number	Pronounced
0	ZERO	9	NINE ER
1	WUN	10	WUN ZERO
2	TOO	11	WUN WUN
3	TREE	33	TREE TREE
4	FO WER	136	WUN TREE SIX
5	FI YIV	500	FI YIV HUN DRED
6	SIX	1478	WUN FO WER SEVEN ATE
7	SEVEN	2100	TOO WUN ZERO ZERO
8	ATE	128.1	WUN TOO EIGHT POINT ONE

3. Characters. The audio panel serves as the 'hub' of radio communications in the aircraft, and is normally set up by the pilot or observer. The scanner needs to know how to select the 'active' aircraft communications radio for transmission. The active radio is selected with the switch on the right-hand side of the panel. Select either COM 1 or COM 2 to transmit and receive on the frequency displayed in the associated radio's primary display.

Letter	Word	Pronunciation	Letter	Word	Pronunciation
A	Alpha	AL FAH	N	November	NOE VEM BER
B	Bravo	BRAH VOH	O	Oscar	OSS CAH
C	Charlie	CHAR LEE	P	Papa	PAH PAH
D	Delta	DELL TAH	Q	Quebec	KEH BEK
E	Echo	ECK OH	R	Romeo	ROW ME OH
F	Foxtrot	FOKS TROT	S	Sierra	SEE AIR AH
G	Golf	GOLF	T	Tango	TANG GO
H	Hotel	HOH TELL	U	Uniform	YOU NEE FORM
I	India	IN DEE AH	V	Victor	VIK TAH
J	Juliet	JEW LEE ETT	W	Whisky	WISS KEY
K	Kilo	KEY LO	X	X-Ray	EKS RAY
L	Lima	LEE MAH	Y	Yankee	YANG KEE
M	Mike	MIKE	Z	Zulu	ZOO LOO

Additional Information

More detailed information on this topic is available in Chapter 4 of the MART.

Evaluation Preparation

Setup: Provide the student access to a radio (may be simulated).

Brief Student: You are a Scanner trainee asked to correctly pronounce numbers and characters as you would when using a radio.

Evaluation

Performance measures

Results

- | | | |
|--|---|---|
| 1. Demonstrate how to pronounce numbers while talking on a radio. | P | F |
| 2. Demonstrate how to pronounce characters while talking on a radio. | P | F |

Student must receive a pass on all performance measures to qualify in this task. If the individual fails any measure, show what was done wrong and how to do it correctly.

O-2020
USE PROWORDS

CONDITIONS

You are a Mission Scanner trainee and must demonstrate proper use of prowords when talking on the radios.

OBJECTIVES

Properly use prowords when talking on the radios.

TRAINING AND EVALUATION

Training Outline

1. As a Mission Scanner trainee, knowledge of proper use of prowords and code words is essential for communicating on the radios.
2. Prowords. Prowords are pronounceable words and phrases that have been assigned a meaning for the purpose of expediting communications on radiotelephone circuits. The table shows samples of the most common prowords.

TERM	DEFINITION or MEANING
AFFIRMATIVE	Yes.
ALL AFTER	The portion of the message that follows (word).
ALL BEFORE	The portion of the message that precedes (word).
BREAK	I hereby indicate the separation of the text from other portions of the message.
COPY	I understand.
CORRECT	You are correct, or what you have transmitted is correct
CORRECTION	An error has been made in this transmission. Transmission will continue with the last word correctly transmitted.
DISREGARD	The last transmission was in error. Disregard it.
DISREGARD THIS TRANSMISSION	This transmission is in error. Disregard it. This proword should not be used to cancel any message that has been completely transmitted and for which receipt or acknowledgment has been received.
EXEMPT	The addresses immediately following are exempted from the collective call.
FIGURE(s)	Numerals or numbers follow.
FROM	The originator of this message is the address designator that follows.
I READ BACK	The following is my response to your instructions to read back.
I SAY AGAIN	I am repeating transmission or portion indicated.
I SPELL	I shall spell the next word phonetically.
I VERIFY	That which follows has been verified at your request and is repeated. To be used only as a reply to VERIFY.
INFO	The addressees immediately following are addresses for information.
INITIALS	Personal initials shall be spoken phonetically prefixed by the word "INITIALS."
MESSAGE FOLLOWS	A message that requires recording is about to follow. Transmitted immediately after the call. (This proword is not used on nets primarily employed for conveying messages. It is intended for use when messages are passed on tactical or reporting nets.)
MORE TO FOLLOW	Transmitting station has additional traffic for the receiving station.
NEGATIVE	No or "permission not granted" or "that is not correct."
OUT	This is the end of my transmission to you and no answer is required or expected.
OVER	This is the end of my transmission to you and a response is necessary. Go ahead; transmit.
PRIORITY	Precedence PRIORITY.
READ BACK	Repeat my message back to me. A request to repeat instructions back to the sender, for the purpose of confirmation. Also, the receiver's reply, repeating the instructions, as in: "Read back is as follows..."
RED CAP	Precedence RED CAP.
RELAY (TO)	Re-transmit this message to...

TERM	DEFINITION or MEANING
ROGER	I have received and understand all of your last transmission. This should not be used to answer a question requiring a yes or no answer.
ROUTINE	Precedence ROUTINE.
SAY AGAIN	Repeat all of your last transmission. Followed by identification data means "Repeat _____ (portion indicated)."
SPEAK SLOWER	Your transmission is at too fast a speed. Reduce speed of transmission.
SPELL, or I SPELL	Please spell, or "I shall spell the next word phonetically."
STANDBY	I must pause for a few seconds.
THIS IS	This transmission is from the station whose designator immediately follows.
TIME	That which immediately follows is the time or date-time group of the message.
TO	The addressees immediately following are addressed for action.
VERIFY	Verify entire message (or portion indicated) with the originator and send correct version. To be used only at the discretion of or by the addressee to which the questioned message was directed.
WAIT	I must pause for a few seconds.
WAIT OUT	I must pause longer than a few seconds.
WILCO	I have received your signal, understand it, and will comply. To be used only by the addressee. <i>Since the meaning of ROGER is included in that of WILCO, these two prowords are never used together.</i>
WORD AFTER	The word of the message to which I have reference is that which follows _____.
WORD BEFORE	The word of the message to which I have reference is that which precedes _____.
WORDS TWICE	Communication is difficult. Transmit each phrase or each code group twice. This proword may be used as an order, request, or as information.

Additional Information

More detailed information on this topic is available in Chapter 4 of the MART.

Evaluation Preparation

Setup: Provide the student access to a radio (may be simulated).

Brief Student: You are a Scanner trainee asked to correctly use prowords, and discuss why code words may be used.

Evaluation

Performance measures

Results

1. Demonstrate understanding and use of prowords while talking on a radio.

P F

Student must receive a pass on all performance measures to qualify in this task. If the individual fails any measure, show what was done wrong and how to do it correctly.

O-2021
INTREPRET EMERGENCY SIGNALS AND DEMONSTRATE
AIR/GROUND TEAM COORDINATION

CONDITIONS

You are a Mission Scanner trainee and must interpret emergency signals and demonstrate how to coordinate with ground teams.

OBJECTIVES

Interpret emergency signals and demonstrate and discuss air and ground team coordination plans and techniques.

TRAINING AND EVALUATION

Training Outline

1. As a Mission Scanner trainee, the ability to interpret emergency signals plus the ability to coordinate with ground teams is essential.
2. While you are on a mission, nonverbal signals may be the only available method of communication (e.g., with a crash survivor or with ground units). Scanners have to interpret these nonverbal messages and must be able to do so accurately regardless of the method used. [Note: You are not required to have these signals memorized, but should be familiar with their use. These tables and figures should be carried in each CAP aircraft; see Attachment 2 of the *Mission Aircrew Reference Text* for examples.]

Light gun signals. If the radio in your aircraft fails, it is still very important for you to follow instructions from the tower at a controlled airport. In this case, you may have to rely on light gun signals from the control tower in order to receive the necessary landing and taxi clearances previously described. These clearance requirements still apply despite an inoperative radio. The table shows each light gun signal, followed by its meaning.

Color and Type of Signal	On the Ground	In Flight
Steady Green	Cleared for takeoff	Cleared to land
Flashing Green	Cleared to taxi	Return for landing
Steady Red	Stop	Give way to other aircraft and continue circling
Flashing Red	Taxi clear of runway area	Airport unsafe—Do not land
Flashing White	Return to starting place on airport	Not applicable
Alternating Red and Green	General warning — exercise extreme caution	

Body signals. The use of the body is one of the most common means of sending messages. These signals are called "body signals" since they involve the whole body, not just arm movements. They are easy to use because no special materials are needed.



Wave Both arms across face

DO NOT ATTEMPT TO LAND



Both arms held over head

PICK UP - PLANE IS ABANDONED



Cup hands over ears

OUR RECEIVER IS WORKING



Lie flat on back with hands above head

NEED MEDICAL ASSISTANCE



Both arms horizontal

NEED MECHANIC HELP or PARTS



Wave one arm over head

ALL OK - DO NOT WAIT

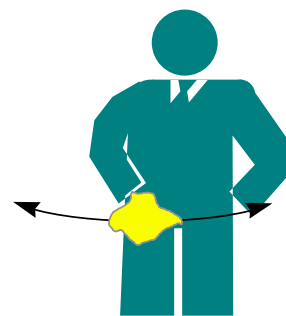

Wave cloth horizontally

NEGATIVE - NO

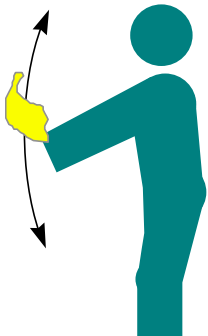

Wave cloth vertically

AFFIRMATIVE - YES



Both arms pointing in the direction of landing while squatting
LAND IN THIS DIRECTION



One arm horizontal

WAIT IF PRACTICAL

A “Paulin” is a short form of tarpaulin, which means waterproof canvas. If the victims of an accident are fortunate enough to have some paulin material, they may be able to aid the rescuers greatly by sending signals with it. If the paulins are laid in clear areas wherein their colors cause high contrasts, they can be seen from substantial distances.

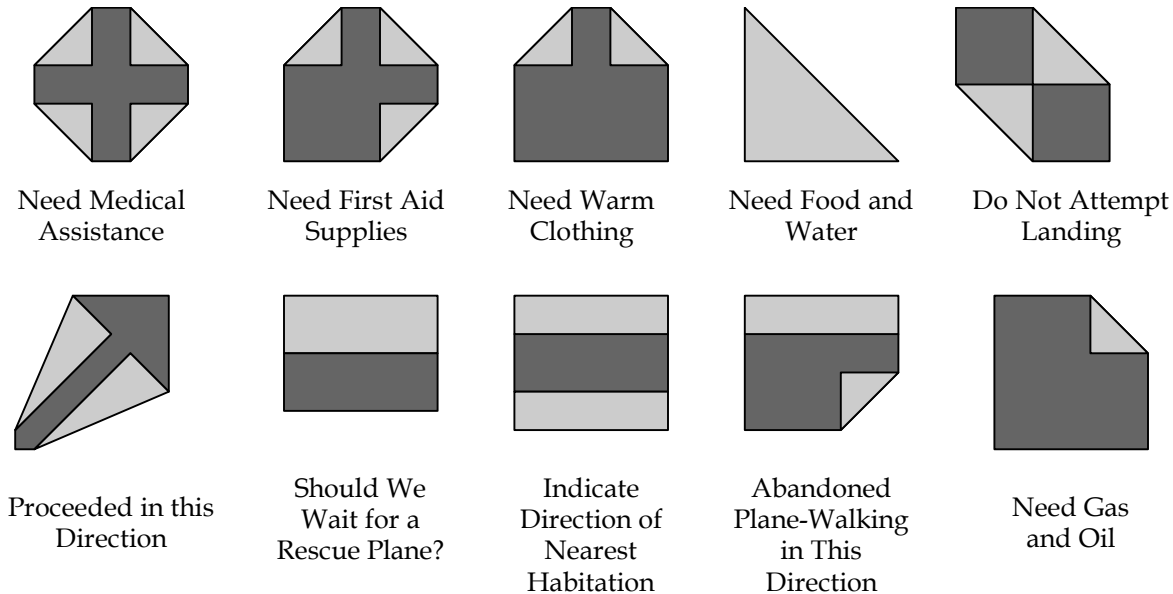

The standard emergency distress signals shown below may be constructed using strips of fabric, pieces of wood, stones, wreckage parts, or any other available material. Each letter should be two to three feet wide and six to twelve feet long, with colors that contrast with the background, if possible.

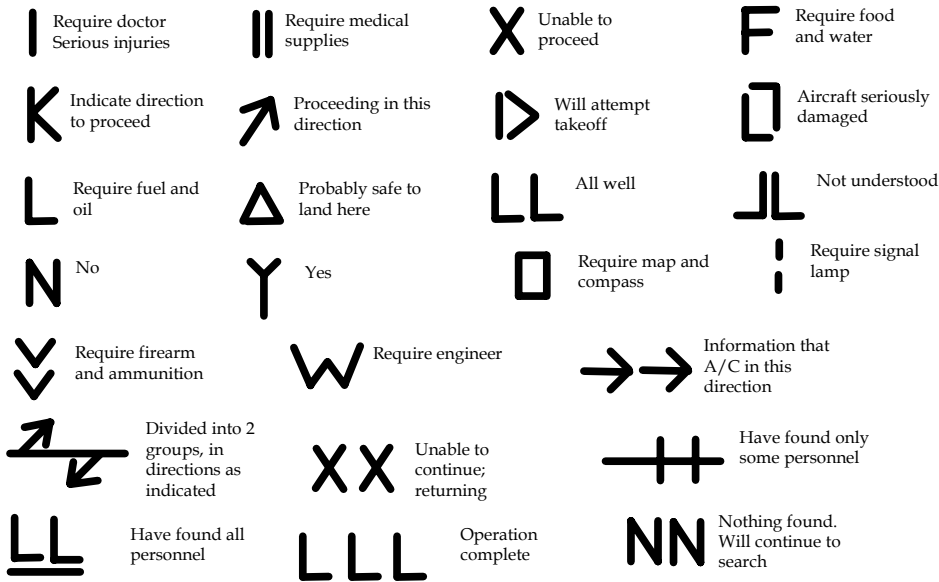

3. Coordinating with ground teams. Naturally, the best means of working with a ground team is to use the radio. As a scanner you should continuously have your eyes on the ground team; this frees the pilot to fly the aircraft and allows the observer to work the radio to execute the coordination. The observer will likely also have to be the one who keeps track of where you “left” your target. Sometimes you may be the one using the radio.

- a. It is important to understand that you have the advantage of perspective; the long-range visibility that is inherent to flying is absent from the ground. You can see over the hills, trees, and other obstacles that are blocking the ground team member's sight, so you may have to explain the situation to the ground pounder in painstaking detail.
 - b. Another perspective problem is time: time seems to pass very slowly while waiting for a ground team, and it is easy to get impatient and leave station prematurely.
 - c. Sometimes the ground team member (non-CAP, of course) may not understand radio jargon, so use plain English. For example, if you wanted a ground team to take a left at the next intersection, what would you say? How about "Ground Team 1, CAP Flight 4239, turn left at the next intersection, over." Most often the plain English answer is the correct way to say it in radioese, anyway.
4. It is important to brief the mission with the ground team, if possible, and at least agree on communications frequencies and lost-comm procedures, maps/charts to be used by *both* teams, determine what vehicle the ground team is driving (e.g., type, color, and any markings), determine what the ground team members are wearing (highly visible vests are preferred), and a rendezvous point and time window for rendezvous (+/- 15 minutes). One tried-and-true method is to rendezvous at a landmark that both the aircrew and the ground team can *easily* identify. A common rendezvous point is an intersection of prominent roads; these are easily identifiable by both the aircrew and ground team. The rendezvous location should be set up before you leave.
5. Also, ground teams that have a hand-held GPS can radio their latitude and longitude coordinates to you and say, "Come and get me!" If you are unable to loiter over the target and bring the ground team to it, you can simply radio the coordinates to the ground team and let them navigate to it on their own. This is not nearly as efficient, however, as when you lead them to it. Note that two pieces of technology have to be working properly to make this work: 1) both air and ground operators need to be proficient with their GPS units and 2) two-way radio communication must be established and maintained.
6. It is important to plan for a loss of communications during the briefing. The teams should agree on pre-arranged signals such as: stopping the vehicle means lost comm; blinking headlights indicate the message has been received; and operating the flashers means the message hasn't been received. The pilot has some techniques that can be used to guide a ground team during lost communications.

Additional Information

More detailed information on this topic is available in Chapter 4 of the MART.

Evaluation Preparation

Setup: Provide the trainee with an aircrew and ground team.

Brief Student: You are a Scanner trainee asked to interpret emergency signals and coordinate with ground units.

Evaluation

Performance measures

Results

- | | | |
|---|---|---|
| 1. Interpret the following emergency signals (may be performed on the ground): | | |
| a. Light gun signals | P | F |
| b. Body signals | P | F |
| c. Paulin signals | P | F |
| d. Distress signals | P | F |
| 1. Discuss scanner responsibilities during a combined air/ground team mission. | P | F |
| 2. Discuss factors to consider before you or the ground team leaves mission base. | P | F |
| 3. Demonstrate basic ground team coordination. | P | F |

Student must receive a pass on all performance measures to qualify in this task. If the individual fails any measure, show what was done wrong and how to do it correctly.

DEMONSTRATE SCANNING PATTERNS AND LOCATE TARGETS

CONDITIONS

You are a Mission Scanner trainee and must use scanning patterns to locate targets.

OBJECTIVES

Use proper scanning patterns to locate an object and a person on the ground.

TRAINING AND EVALUATION

Training Outline

1. As a Mission Scanner trainee, the ability to use proper scanning patterns to locate objects on the ground is essential. Scanning is the process of investigating, examining, or checking by systematic search. In search and rescue operations, the scanner visually searches for distress signals or accident indications by using a systematic eye movement pattern. Refer to Chapter 5 of the MART for figures.

2. Vision. The brain actively senses and is aware of everything from the point outward to form a circle of 10 degrees (visual acuity outside of this cone of vision is only ten percent of that inside the cone). This is central vision, produced by special cells in the fovea portion of the eye's retina. Whatever is outside the central vision circle also is "picked up" by the eyes and conveyed to the brain, but it is not perceived clearly. This larger area is called peripheral vision; cells less sensitive than those in the fovea produce it. For example, an object that is visible one mile away using central vision would only be visible 500 feet away using peripheral vision. However, objects within the peripheral vision area can be recognized if mental attention is directed to them.

Note that peripheral vision is very important at night, and is also important in picking up structures such as towers.

3. Fixation area. The fixation area is the area in which "concentrated" looking takes place. If the search objective happens to come within this fixation area, you probably will recognize it. For central vision to be effective, the eye must be focused properly. This focusing process takes place each time the eyes, or head and eyes, are moved. When you are not actively focusing while looking outside the aircraft, your focal point will be a point about 30 feet out. Thus, daydreaming or thinking about other things while you are supposed to be looking for the target will guarantee you will not see the target even if your eyes are pointed right at it!

4. Fixation points and lines of scan. When you wish to scan a large area, your eyes must move from one point to another, stopping at each point long enough to focus clearly. Each of these points is a fixation point. When the fixation points are close enough the central vision areas will touch or overlap slightly. Spacing of fixation points should be 3 or 4 degrees apart to ensure the coverage will be complete. Consciously moving the fixation points along an imaginary straight line produces a band of effective "seeing."

5. Fixation area. The goal of scanning techniques is to thoroughly cover an assigned search area. Reaching this goal on a single overflight is not possible for a number of reasons. First, the eye's fixation area is a circle and the search area surface (ground) is flat. Coverage of a flat surface with circles requires much overlapping of the circles. This overlapping is not possible on a search mission because of the aircraft's motion. Also, the surface area covered by the eye's fixation area is less for the area near the airplane and increases with distance from the airplane. The net result is relatively large gaps in coverage near the airplane and some overlap as distance from the airplane increases. Angular displacement is the angle formed from a point almost beneath the airplane outward to the scanning range, or beyond. By this definition, the horizon would be at 90 degrees

displacement. Although the fixation area may be a constant 10-degree diameter circle, the effectiveness of sighting the objective decreases with an increase in this angular displacement. Said another way, your ability to see detail will be excellent at a point near the aircraft, but will decrease as the angular displacement increases. At the scanning range, at which the angular displacement may be as much as 45 degrees, the resolution of detail area probably will have shrunk to a 4-degree diameter circle. This is why having scanners looking out both sides of the aircraft is optimal. With track spacing (explained later) proper for the given search visibility, each scanner will look at roughly the same area (i.e., double coverage).

6. Field of scan. The area that you will search with your eyes in lines of scan is called the field of scan. The upper limit of this field is the line that forms the scanning range. The lower limit is the lower edge of the aircraft window, while the aft (back) limit is usually established by the vertical edge of the aircraft window. The forward (front) limit for a field of scan will vary. It might be established by a part of the airplane (such as a wing strut). Or, when two scanners are working from the same side of the airplane it might be limited by an agreed-upon point dividing the field of scan.

7. Scanning range. We are using the term "scanning range" to describe the distance from an aircraft to an imaginary line parallel to the aircraft's ground track (track over the ground.) This line is the maximum range at which a scanner is considered to have a good chance at sighting the search objective.

Scanning range sometimes may be confused with search visibility range. Search visibility range is that distance at which an object the size of an automobile can be seen and recognized. Aircraft debris may not be as large as an automobile and may not be immediately recognizable as aircraft debris, particularly when the aircraft is flying at 100 mph. Therefore, scanning range may be less than but never greater than the search visibility (in CAP searches, we rarely credit a search visibility of greater than three or four nautical miles).

If your pilot states that the search altitude will be 500 feet above the ground level (AGL), you can expect your scanning range to be $\frac{1}{4}$ to $\frac{1}{2}$ mile. If the search altitude is 1,000 feet AGL, you can expect a scanning range of between $\frac{1}{2}$ and 1 mile. Even so, there are many variables that affect both the effective scanning range and your probability of detecting the search objective. These issues are discussed later.

8. Scanning patterns. To cover the field of scan adequately requires that a set pattern of scan lines be used. Research into scanning techniques has shown that there are two basic patterns that provide the best coverage. These are called the *diagonal pattern* and the *vertical pattern*. The diagonal pattern is the better of the two.

The diagonal pattern begins with the first fixation point slightly forward of the aircraft's position, and the scanner moves her fixation points sequentially back toward the aircraft. The next scan line should be parallel to the first, and so on. Each succeeding scan line is started as quickly as possible after completing the previous one. Remember, the duration of each fixation point along a scan line is about $\frac{1}{3}$ second: how long it takes to complete one scan line depends on the distance at which the scanning range has been established. Also, the time required to begin a new scan line has a significant influence on how well the area nearest the airplane is scanned. In other words, more time between starting scan lines means more space between fixation points near the airplane.

The vertical pattern is somewhat less effective. You should use this pattern only from a rear seat position, and the first fixation point should be as near to underneath the airplane as you can see. Subsequent fixation points for this first scan line should progress outward to the scanning range and back. This scanning pattern traces a "sawtooth" shape on the surface.

Note: If there are two scanners on the same side of the airplane, it is good practice to combine the diagonal and vertical patterns. As agreed between scanners, one would use the diagonal pattern and the other the vertical pattern. However, the scanner using the vertical pattern *would not* scan to the scanning range. Some distance

short of the scanning range would be selected as the vertical pattern limit. This technique provides good coverage of the surface area near the search aircraft.

Additional Information

More detailed information and pictures on this topic are available in Chapter 5 of the MART.

Evaluation Preparation

Setup: Provide the student with an aircraft and aircrew (scanning techniques may be simulated on the ground).

Place a target (preferably to simulate aircraft wreckage) in the search area, and have a person (or mannequin) in the same general area. Fly the search area at 1000' AGL and 90-100 knots.

Brief Student: You are a Scanner trainee asked to demonstrate scanning patterns and locate targets in a search area.

Evaluation

<u>Performance measures</u>	<u>Results</u>	
1. Define "scanning" and "fixation," and describe how aircraft motion effects scanning.	P	F
2. Demonstrate knowledge of central and peripheral vision, and describe where your focal point is when your eyes are relaxed.	P	F
3. Demonstrate knowledge of fixation points and lines of scan, and define "scanning range."	P	F
4. Demonstrate diagonal and vertical scanning patterns.	P	F
5. Locate a target in a search area.	P	F
6. Locate a person in a search area.	P	F

Student must receive a pass on all performance measures to qualify in this task. If the individual fails any measure, show what was done wrong and how to do it correctly.

DEMONSTRATE TECHNIQUES TO REDUCE FATIGUE

CONDITIONS

You are a Mission Scanner trainee and must demonstrate and discuss how to minimize fatigue.

OBJECTIVES

Demonstrate techniques to minimize fatigue, and how you would direct the pilot during flight.

TRAINING AND EVALUATION

Training Outline

1. As a Mission Scanner trainee, knowing how to minimize fatigue is essential. The art of scanning is more physically demanding and requires greater concentration than mere sight seeing. In order to maintain scanning effectiveness you must be aware of your own fatigue level. The following can help maintain scanning effectiveness:
 - a. Change scanning positions at 30- to 60-minute intervals, if aircraft size permits.
 - b. Rotate scanners from one side of the aircraft to the other, if two or more scanners are present.
 - c. Find a comfortable position, and move around to stretch when necessary.
 - d. Clean aircraft windshields and windows. Dirty windows accelerate the onset of eye fatigue, and can reduce visibility by up to 50 percent.
 - e. Scan through open hatches whenever feasible.
 - f. At night, use red lights and keep them dimmed to reduce reflection and glare.
 - g. Use binoculars (sparingly) to check sightings.
 - h. Focus on a close object (like the wing tip) on a regular basis. The muscles of the eye get tired when you focus far away for an extended period of time.
 - i. Rest during turns outside the search area.

2. The "clock position" system is used to describe the relative positions of everything outside the airplane, with the nose of the aircraft being "12 o'clock." The system considers positions to be on a horizontal plane that is centered within the cockpit, and any object above or below this plane is either "high" or "low."

Additional Information

More detailed information on this topic is available in Chapter 5 of the MART.

Evaluation Preparation

Setup: Provide the student access to an aircraft (may simulate on the ground).

Brief Student: You are a Scanner trainee asked how to minimize fatigue during searches.

Evaluation

<u>Performance measures</u>	<u>Results</u>
1. Discuss fatigue effects and demonstrate how to minimize fatigue.	P F
2. Describe how to direct the pilot using the "clock position" method.	P F

Student must receive a pass on all performance measures to qualify in this task. If the individual fails any measure, show what was done wrong and how to do it correctly.

O-2024
USE SECTIONAL CHARTS

CONDITIONS

You are a Mission Scanner trainee and must discuss the information displayed on a sectional chart and determine heading and distance

OBJECTIVES

Discuss the information displayed on a sectional chart and to determine heading and distance.

TRAINING AND EVALUATION

Training Outline

1. As a Mission Scanner trainee, basic knowledge the information contained on a sectional chart and its use is essential. The most important tool you will use in both mission flight planning and execution is the chart. Highway road maps are usually not acceptable for air navigation, since most don't have detailed terrain depiction and also lack the superimposed reference system. Many aeronautical charts have such small scales that the makers are unable to show required levels of detail when trying to put a large area into a small chart space. The most useful chart that has been widely accepted for visual, low-altitude navigation is the *sectional aeronautical chart*, sometimes simply referred to as the "*sectional*".
2. Sectional chart. Sectionals use a scale of one to five hundred thousand, or 1:500,000, where all features are shown 1/500,000 of their actual size (1 inch = 6.86 nm). This allows accurate depiction of both natural and cultural features without significant clutter. Sectionals portray the following:
 - a. Physical, natural features of the land, including terrain contours or lines of equal elevation.
 - b. Man-made or cultural development, like cities, towns, towers, and racetracks.
 - c. Visual and radio aids to navigation, airways, and special-use airspace.
 - d. Airports and airport data, lines of magnetic variation, controlled airspace, obstructions and other important information.
 - e. VFR waypoints.
 - f. Obstructions to flight.
3. Legend. An often overlooked but vital part of the sectional is the 'Legend.' This is a written explanation of symbols, projections, and other features used on the chart. Other important areas of the chart are its title page or "panel", and the margins around the chart edges. The margins contain supplemental radio frequency information, details about military or *special use airspace*, and other applicable regulations. The title panel identifies the region of the country shown by the chart, indicates the scale used in drawing the chart, explains elevations and contour shading, and shows the expiration date of the chart and effective date of the next issue of that chart. *It is vitally important that you keep current charts in the aircraft at all times.*
4. Interpretation. A significant part of air navigation involves interpreting what one sees on the chart, then making comparisons outside the aircraft. Basic chart symbols can be grouped into cultural features, drainage features, and relief features.

Understanding *cultural features* is straightforward, and they usually require little explanation. Villages, towns, cities, railroads, highways, airports or landing strips, power transmission lines, towers, mines, and wells are all examples of cultural features. The chart legend explains the symbols used for most cultural features, but if no standard symbol exists for a feature of navigational significance, the cartographer frequently resorts to printing the name of the feature itself, such as *factory* or *prison*, on the chart.

Drainage features on charts include lakes, streams, canals, swamps, and other bodies of water. On sectional charts these features are represented by lightweight solid blue lines for rivers and streams; large areas of water, such as lakes and reservoirs, are shaded light blue with the edges defined by lightweight solid blue lines. Under most conditions, the drainage features on a map closely resemble the actual bodies of water. However, certain bodies of water may change shape with the season, or after heavy rains or drought. Where this shape change occurs with predictability, cartographers frequently illustrate the maximum size expected for a body of water with light-weight, blue, dashed lines. If you intend to use drainage features for navigation, you should consider recent rains or dry spells while planning and remember the body of water may not appear exactly as depicted on the chart.

Relief features indicate vertical topography of the land including mountains, valleys, hills, plains, and plateaus. Common methods of depicting relief features are contour lines, shading, color gradient tints, and spot elevations. Contour lines are the most common method of depicting vertical relief on charts. The lines do not represent topographical features themselves, but through careful study and interpretation, you can predict a feature's physical appearance without actually seeing it. Each contour line represents a continuous imaginary line on the ground on which all points have the same elevation above or below sea level, or the zero contours. Actual elevations above sea level of many contour lines are designated by a small break in the line, while others are not labeled. Contour interval, or vertical height between each line, is indicated on the title panel of sectionals. Contour lines are most useful in helping us to visualize vertical development of land features. Contour lines that are grouped very closely together indicate rapidly changing terrain, such as a cliff or mountain. More widely spaced lines indicate more gentle slopes. Absence of lines indicates flat terrain. Contour lines can also show changes in the slope of terrain.

Shading is added to sectional charts to help highlight and give contrast to the contour lines. These tiny gray dots are applied adjacent to selected contour lines and give the contours a three-dimensional appearance. This makes it easier to imagine the physical appearance of the shaded topographical feature. Gradient tints, the "background" colors on charts, indicate general areas of elevation. The height range assigned to each gradient color is indicated on the title panel of each sectional chart. Areas that are near sea level are pale green, while *high terrain is color-coded a deep red/brown*. Intermediate elevations are indicated by brighter shades of green, tan, or lighter shades of red/brown.

5. Aeronautical data. The aeronautical information on the sectional charts is for the most part self-explanatory. An explanation for most symbols used on aeronautical charts appears in the margin of the chart. Additional information appears at the bottom of the chart.

Information concerning very high frequency (VHF) radio facilities such as tower frequencies, omnidirectional radio ranges (VOR), and other VHF communications frequencies is shown in blue. A narrow band of blue tint is also used to indicate the centerlines of Victor Airways (VOR civil airways between omnirange stations). Low frequency-medium frequency (LF/MF) radio facilities are shown in magenta (purplish shade of red).

Runway patterns are shown for all airports having permanent hard surfaced runways. These patterns provide for positive identification as landmarks. All recognizable runways, including those that may be closed, are shown to aid in visual identification. Airports and information pertaining to airports having an airport traffic area (operating control tower) are shown in blue. All other airports and information pertaining to these airports are shown in magenta adjacent to the airport symbol that is also in magenta.

The symbol for obstructions is another important feature. The elevation of the top of obstructions above sea level is given in blue figures (without parentheses) adjacent to the obstruction symbol. Immediately below this set of figures is another set of lighter blue figures (enclosed in parentheses) that represent the height of the top of the obstruction above ground-level. Obstructions which extend less than 1,000 feet above the terrain are

shown by one type of symbol and those obstructions that extend 1,000 feet or higher above ground level are indicated by a different symbol (see sectional chart). Specific elevations of certain high points in terrain are shown on charts by dots accompanied by small black figures indicating the number of feet above sea level. The chart also contains larger bold face blue numbers that denote Maximum Elevation Figures (MEF). These figures are shown in quadrangles bounded by ticked lines of latitude and longitude, and are represented in thousands and hundreds of feet above mean sea level. The MEF is based on information available concerning the highest known feature in each quadrangle, including terrain and obstructions (e.g., trees, towers, and antennas). Since CAP aircraft regularly fly at or below 1000' AGL, aircrews should exercise extreme caution because of the numerous structures extending up as high as 1000' – 2000' AGL. Additionally, guy wires that are difficult to see even in clear weather support most truss-type structures; these wires can extend approximately 1500 feet horizontally from a structure. Therefore, all truss-type structures should be avoided by at least 2000 feet (horizontally and vertically).

6. Determining heading and distance. To determine a heading, locate the departure and destination points on the chart and lay the edge of a special protractor, or *plotter*, along a line connecting the two points. Read the true course for this leg by sliding the plotter left or right until the center point, or grommet, sits on top of a line of longitude. When the course is more to the north or south, you can measure it by centering the grommet on a parallel of latitude, then reading the course from the inner scale that's closer to the grommet. To determine distance, use the scale that's printed on the plotter's straight edge: one edge measures nautical miles and the other statute miles.

7. Grids. CAP has adopted a standard grid system built upon the matrix of parallels of latitude and meridians of longitude and the sectional aeronautical chart. Sectional charts cover a land area approximately seven degrees of longitude in width and four degrees of latitude in height. Information pertaining to gridding can be found in Attachment E of the *U.S. National SAR Supplement to the International Aeronautical and Maritime SAR Manual* (or Attachment 1 of the MART).

The sectional grid system used by Civil Air Patrol divides each sectional's area into 448 smaller squares. This process begins by dividing the whole area into 28 *1-degree* grids, using whole degrees of latitude and longitude. Then each 1-degree grid is divided into four *30-minute* grids, using the 30-minute latitude and longitude lines. Finally, each of the 30-minute grids is divided into four *15-minute* grids, using the 15- and 45-minute latitude and longitude lines.

When circumstances require, a 15-minute grid can be divided into four more quadrants using 7 1/2 degree increments of latitude and longitude, creating four equal size grids that are approximately 7 1/2 miles square. The quadrants are then identified alphabetically - A through D - starting with the northwest quadrant as A, northeast as B, southwest as C and southeast as D. [If needed, a 7 1/2 degree grid can be further subdivided into four quadrants using the same methodology: using the 7 1/2 degree grid 'A', the quadrants would be labeled AA, AB, AC and AD.]

Another means of designating a grid system is the *Standardized Latitude and Longitude Grid System*. It has an advantage over the sectional standardized grid in that it can be used on any kind of chart that has lines of latitude and longitude already marked. In this system, 1-degree blocks are identified by the intersection of whole numbers of latitude and longitude, such as 36-00N and 102-00W: these points are always designated with the latitude first, such as 36/102, and they identify the area north and west of the intersection of these two lines. Next, the 1-degree grid is divided into four quadrants using the 30-minute lines of latitude and longitude. Label each quadrant A through D; the northwest quadrant being 36/102A, the northeast 36/102B, the southwest 36/102C, and the southeast 36/102D. Each quadrant can also be divided into four sub-quadrants, labeled AA, AB, AC, and AD, again starting with the most northwest and proceeding clockwise.

Additional Information

More detailed information and pictures on this topic are available in Chapter 8 of the MART.

Evaluation Preparation

Setup: Provide the student with a sectional chart and a plotter.

Brief Student: You are a Scanner trainee asked to discuss the information displayed on a sectional chart, and to determine heading and distance.

Evaluation

<u>Performance measures</u>	<u>Results</u>
1. Identify and discuss the following on an aeronautical sectional chart:	P F
a. Physical features such as topographical details.	P F
b. Towns, cities, highways, roads, and towers (MSL and AGL).	P F
c. Airways, radio aids, airports and airport data.	P F
d. Maximum Elevation Figures.	P F
e. Legend and margin information.	P F
2. Given a sectional and plotter, determine a heading and measure distances.	P F
3. State the size of a full and one-quarter CAP and Standardized grids.	P F

Student must receive a pass on all performance measures to qualify in this task. If the individual fails any measure, show what was done wrong and how to do it correctly.

TRACK AND RECORD POSITION ON SECTIONALS AND MAPS

CONDITIONS

You are a Mission Scanner trainee and must demonstrate basic use of navigational terms, determine heading and distance, and determine the position of the aircraft and ground features.

OBJECTIVES

Demonstrate basic knowledge and use of navigational terms. Determine the aircraft's heading and the distance between two points. Given a sectional chart, record a ground feature and transfer that location to a map.

TRAINING AND EVALUATION

Training Outline

1. As a Mission Scanner trainee, a basic knowledge of navigational terms, the ability to determine heading and distance, and the ability to record a ground feature on a sectional and a map is essential. In order to effectively communicate with the pilot and ground units, the mission scanner must have a clear understanding of various terms that are used frequently when flying aboard CAP aircraft. These are not peculiar to search and rescue, but are used by all civilian and military aviators. The scanner must also be able to track the aircraft's position, and relay the location of ground features to both the pilot and observer and units on the ground.
2. Course. Course refers to the planned or actual path of the aircraft over the ground. The course can be either *true course* or *magnetic course* depending upon whether it is measured by referencing true north or magnetic north. The magnetic north pole is *not* located at the true North Pole on the actual axis of rotation, so there is usually a difference between true course and magnetic course.
3. Heading. Heading is the direction the aircraft is *physically* pointed. True heading is based on the true North Pole, and magnetic heading is based on the magnetic north pole. Most airplane compasses can only reference magnetic north without resorting to advanced techniques or equipment, so headings are usually magnetic.
6. Drift is the effect the wind has on an aircraft. The motion of the airplane relative to the surface of the earth depends upon the fact that the airplane is moving relative to an air mass and the air mass is moving relative to the surface of the earth. Adding these two gives the resultant vector of the airplane moving relative to the surface of the earth. The angle between the heading and the actual ground track is called the drift angle. Drift is corrected by changing the aircraft's heading just enough to negate drift.
5. Ground track. The actual path of the airplane over the surface of the earth is called the ground track. An airplane's track over the ground doesn't always correspond with the direction it's pointed (heading). This is due to the effect of wind (drift). All GPS units will display ground track.
6. A nautical mile is about 6076 feet (sometimes rounded to 6080 feet), compared to 5280 feet for the statute mile. Most experienced aviators simply refer to a nautical mile as a mile. *Scanners and Observers should remain aware of this difference when communicating with ground search teams because most ground or surface distances are measured using statute miles or kilometers.* To convert nautical miles into statute miles, multiply nautical miles by 1.15. To find kilometers, multiply nautical miles by 1.85. Also, one nautical mile is equal to one minute of latitude: this provides a convenient scale for measuring distances on any chart. Nautical miles are abbreviated "nm".

7. A knot is the number of nautical miles flown in one hour. Almost all airspeed indicators measure speed in terms of knots, not miles per hour. One hundred knots indicates that the aircraft would fly one hundred nautical miles in one hour in a no-wind condition. Knots can be used to measure both *airspeed* and *ground speed*.

8. Latitude and Longitude. Navigation begins with is a common reference system or imaginary grid "drawn" on the earth's surface by *parallels of latitude* and *meridians of longitude*. This system is based on an assumption that the earth is spherical. In reality, it's slightly irregular, but the irregularities are small, and errors caused by the irregularities can be easily corrected. The numbers representing a position in terms of latitude and longitude are known as the coordinates of that position. Each is measured in degrees, and each degree is divided into 60 smaller increments called minutes. Each minute may be further divided into 60 seconds, or tenths and hundredths of minutes.

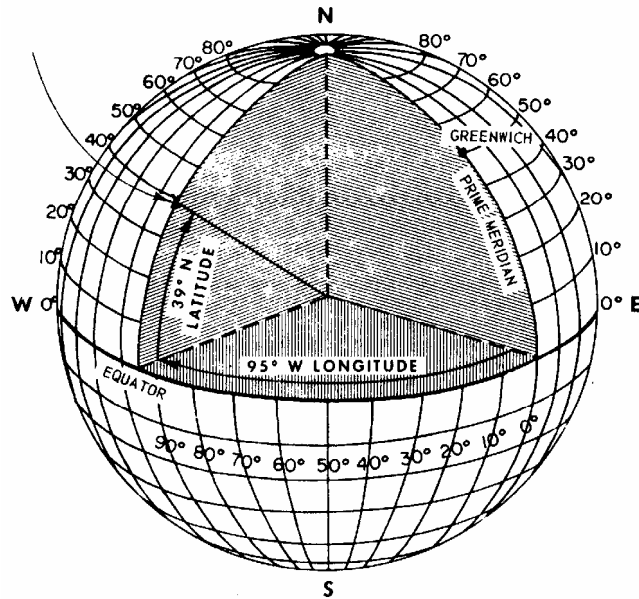

Latitude is the angular distance of a place north or south from the equator. The equator is a great circle midway between the poles. Parallel with the equator are lines of latitude. Each of these parallel lines is a small circle, and each has a definitive location. The location of the latitude is determined by figuring the angle at the center of the earth between the latitude and the equator. The equator is latitude 0°, and the poles are located at 90° latitude. Since there are two latitudes with the same number (two 45° latitudes, two 30°, etc.) the letter designators N and S are used to show which latitude is meant. The North Pole is 90° north of the equator and the South Pole is 90° south of the equator.

Longitude is counted east and west from the Greenwich (zero) meridian through 180°. Thus the Greenwich Meridian is zero degrees longitude on one side of the earth, and after crossing the poles it becomes the 180th meridian (180° east or west of the 0° meridian). Therefore all longitudes are designated either E or W.

Using latitude and longitude, any position on a map or chart can be identified. When identifying a location by its position within this latitude/longitude (lat/long), you identify the position's coordinates *always indicating latitude first* and then longitude. For example, the coordinates N 39° 04.1', W 95° 37.3' are read as "North thirty-nine degrees, four point one minutes; West ninety-five degrees, thirty-seven point three minutes." If you locate these coordinates on *any* appropriate aeronautical chart of North America, you will *always* find Philip Billard Municipal Airport in Topeka, Kansas.

9. Heading and distance. To determine a heading, locate the departure and destination points on the chart and lay the edge of a special protractor, or *plotter*, along a line connecting the two points. Use a marker to trace the

route. Read the true course for this leg by sliding the plotter left or right until the center point, or grommet, sits on top of a line of longitude. When the course is more to the north or south, you can measure it by centering the grommet on a parallel of latitude, then reading the course from the inner scale that's closer to the grommet. [As a "stupid check," note the heading in terms of cardinal points (e.g., N, NW, NNW), and see if this agrees with your first result.]

To determine the distance you're going to travel, lay the plotter on the route and read the distance using the scale that's printed on the plotter's straight edge: one edge measures nautical miles and the other statute miles.

10. Tracking current position. Knowing how to track the aircraft's progress on a sectional chart and a map is essential in order to maintain situational awareness. This, in turn, allows you to accurately mark targets. We previously discussed how to use navigational aids and a sectional chart to plot and navigate a course; the same principles are used during flight to keep track of the aircraft's current position and to record sightings. Besides tracking your position by looking at ground features and following along on your sectional, the pilot or observer can use the VORs, DME and the GPS to update you on current position.

There are a number of ways you can add information to your chart that will help during the flight. Tick marks along the course line at specific intervals will help you keep track of your position during flight (situational awareness). Some individuals prefer five- or ten-nautical mile (nm) intervals for tick marks, while others prefer two- or four-nm intervals. Four-nautical mile spacing works well for aircraft that operate at approximately 120 knots. Since the 120-knot airplane travels 2 nm every minute, each 4 nm tick mark represents approximately two minutes of flight time. On the left side of the course line you have more tick marks, at five-nm intervals, but measured backward from the destination. In flight, these continuously indicate distance remaining to the destination, and you can easily translate that into the time left to your destination.

The next step in preparing the chart is to identify *checkpoints* along the course; you can use these to check your position on- or off-course, and the timing along the leg. Prominent features that will be easily seen from the air make the best checkpoints, and many like to circle them or highlight them with a marker in advance. You should select easy (large) targets such as tall towers, cities and towns, major roads and railroads, and significant topological features such as lakes and rivers. Try not to select checkpoints that are too close together. During a mission, checkpoint spacing will be controlled by the search altitude and weather conditions and visibility at the time of the flight.

11. Recording and reporting position. Being able to record and report the position of a ground feature is a critical skill in all CAP ES missions. Once an aircrew locates a downed aircraft or determines the location of a breach in a levy, they must be able to pinpoint the location on the sectional and report that position to others. Since the details on the sectional chart are often not detailed enough to be useful to ground units, the scanner usually has to transfer that information to a map (e.g., road or topographical).

Using all available tools (i.e., VOR, DME, GPS, and visual references), record the position of the target (e.g., aircraft, levy, spill, or damaged plant) on the sectional. Using lat/long coordinates or the target's relation to observable ground features (e.g., roads, rivers, towns, etc.), transfer the target's position to a road or topo map. [Remember, an important part of planning a mission includes ensuring that you have the same kind of map that the ground units are using, so the position you give them will be easily understandable.]

Additional Information

More detailed information on this topic is available in Chapter 8 of the MART.

Evaluation Preparation

Setup: Provide the student with a plotter, a sectional chart and a map.

Brief Student: You are a Scanner trainee asked to discuss navigation terms, determine a heading and the distance between two points, and given a sectional and a map, locate an aircraft's current position and record the position of a ground feature.

Evaluation

<u>Performance measures</u>	<u>Results</u>
1. Discuss the use of the following navigational terms:	P F
a. Course, heading and ground track.	P F
b. Nautical mile and knot.	P F
2. Given a plotter and a sectional, determine a route's heading and distance.	P F
3. Given a sectional, record a ground position by its latitude/longitude and then record that position on a road or topo map.	P F

Student must receive a pass on all performance measures to qualify in this task. If the individual fails any measure, show what was done wrong and how to do it correctly.

O-2101
DESCRIBE HOW ELTs ARE DETECTED

CONDITIONS

You are a Mission Observer trainee and must describe how ELTs are detected and a search is launched.

OBJECTIVES

Describe how ELTs are detected and a search is launched.

TRAINING AND EVALUATION

Training Outline

1. As a Mission Observer trainee, knowing the types of Emergency Locator Transmitters (ELTs), how they can be detected, and how a search is launched is essential. While the observer's role seems to be concentrated in visual searches, her contributions in electronic searches are no less important. The observer's understanding of electronic search techniques, and her ability to assist the pilot, can substantially increase both search effectiveness and the timeliness of recovering accident victims.

2. Types of ELTs. The Federal Aviation Administration (FAA) requires most U.S.-registered aircraft to have operable ELTs installed, which activate automatically when sensing acceleration forces during an accident. An active ELT transmits a continuous radio signal on a specific frequency until it's either deactivated or its battery discharges: most transmit on 121.5 MHz at 60-100 milliwatts (less power than a small flashlight). [Note: After 01FEB09, advanced ELTs that transmit on 406.025 MHz at 25 milliwatts are to be used. They are specifically designed to operate with the Cospas-Sarsat satellite system, and transmit data that contains a unique identifier number that links them to a database containing information on the vessel or aircraft and emergency points of contact. Some advanced 406 MHz beacons also transmit GPS coordinates.]

Military Beacons (e.g., URT-33/C) operate on 253 MHz. Personnel ejecting/parachuting from a military aircraft have this beacon; some pilots may be able to communicate via two-way radio on 243 MHz using a PRC-90 or later military survival radio (this radio also has a beacon mode).

Marine Emergency Position Indicating Radio Beacons (*EPIRBs*) are primarily found on boats and ships. Similar to ELTs, some are automatically activated while others can only be activated manually.

Personal Locator Beacons (PLBs) and Personal Emergency Transmitters (PETs) are currently illegal for general use in the U.S., but the law is about to be changed and they are presently used by some government agencies. They transmit on 121.5 MHz, 243 MHz and 406 MHz or a combination: the new law proposes to license only the 406 MHz version.

Test stations or *practice beacons* like those used by CAP transmit on 121.775 MHz. Some organizations still operate practice beacons on 121.6 MHz, but all CAP practice beacons should be converted by now. [NOTE: **Avoid calling the practice beacon an "ELT"** while communicating on the radio; this can cause confusion. The term "practice beacon" is very clear to all concerned and should be used on all drills and exercises.]

3. Approximately 97% of all received ELT signals turn out to be false alarms. For 121.5 MHz ELTs only 1 in 1000 signals is an actual emergency! False alarms cause problems because SARSAT can only monitor 10 ELT signals at a time and because they block the emergency frequencies (thus blocking a real emergency signal). However, you must *always treat an ELT signal as an emergency* because you can't know whether the signal is real or false.

4. In a cooperative effort among several nations, search and rescue-dedicated satellites (SARSAT and COSPAS) orbit the earth and alert to ELT transmissions. Upon receiving an ELT signal, the SARSAT derives the approximate lat/long coordinates of the ELT's position, and the coordinates are passed through the Air Force Rescue Coordination Center (AFRCC) to the incident commander.
5. AFRCC will not launch a search until the signal is picked up by at least two satellites. Also, system accuracy in pinpointing the location varies. For a typical 121.5 MHz ELT, accuracy is limited to a 12 nm radius (452 square nm); a 406 MHz ELT can be narrowed down to a 2 nm radius (12.5 square nm) and one with GPS can be narrowed down to a 0.05 nm radius (0.008 square nm).
6. Upon receiving SARSAT coordinates, or determining that an ELT was aboard a missing aircraft, the incident commander may launch a combined ELT/visual route search. Search success may depend upon several factors. The fact that an ELT was aboard a missing aircraft does not necessarily guarantee that electronic search procedures will locate it because the unit may have been inoperative or the batteries totally discharged. Also, the crash forces may have been insufficient to activate the ELT or so severe that it was damaged. Incident commanders may attempt to maximize the search effort by conducting an electronic search and a general visual search simultaneously when weather and other circumstances permit.

Additional Information

More detailed information and figures on this topic are available in Chapter 10 of the MART.

Evaluation Preparation

Setup: Provide the student access to an aircraft ELT (or pictures).

Brief Student: You are a Mission Observer trainee asked to describe how ELTs are detected and a search launched.

Evaluation

<u>Performance measures</u>	<u>Results</u>
1. Discuss the various types of ELTs.	P F
2. Describe how an ELT is detected and a search is launched.	P F

Student must receive a pass on all performance measures to qualify in this task. If the individual fails any measure, show what was done wrong and how to do it correctly.

O-2102
DEMONSTRATE PLANNING AND FLYING A ROUTE SEARCH

CONDITIONS

You are a Mission Pilot trainee and must demonstrate how to plan and fly a route search.

OBJECTIVES

Demonstrate how to plan and fly a route search.

TRAINING AND EVALUATION

Training Outline

1. As a Mission Pilot trainee, the ability to plan and perform a route search pattern is essential.
2. General. Because of the accuracy and reliability of the present Global Positioning System and GPS receivers, CAP aircrews are now able to navigate and fly search patterns with unprecedented effectiveness and ease. The GPS has become the primary instrument for CAP air missions, and it is vital that observers know how to setup and use the GPS. However, observers must also be familiar with the other navigational instruments onboard CAP aircraft: these instruments complement the GPS and serve as backups in case of GPS receiver problems.

The pilot (or the observer acting as mission commander) must be aware of how many scanners will be on board in order to assign which side of the aircraft they should scan. *Planning and executing a search pattern with only one scanner on board is quite different from one where you have two scanners.* Likewise, having an observer and two scanners on board will allow the observer to spend more time assisting the pilot without seriously decreasing search effectiveness.

When you are planning and flying search patterns, always perform a stupid check -- as in "Hey! Wait a minute. This is stupid." Use this to see if your headings, waypoint positions, lat/long coordinates and distances look sensible. At a minimum, perform this check after you finish planning, when you start your pattern, and periodically thereafter. For example, you've just entered a set of lat/long coordinates into the GPS and turned to the heading shown on the GPS. You know the coordinates represent a lake southwest of your position, so check the heading indicator to see you're actually traveling in a southwesterly direction. Or, you know the lake is approximately 25 miles away; check the distance indicated on the GPS! You'd be surprised how many mistakes this method will catch.

Pre-planning (plotting) your search pattern results in the most effective search. Pre-planning sets the details of the sortie in your mind and makes entering your data (correctly) into the GPS much easier. This allows the pilot and observer to concentrate on their primary task by minimizing navaid setup time and reducing confusion. Worksheets can be used (see the *Flight Guide*, MART Attachment 2) to pre-plan your search patterns, but they are just one method.

3. Route search pattern. The route (track line) search pattern is normally used when an aircraft has disappeared without a trace. This search pattern is based on the assumption that the missing aircraft has crashed or made a forced landing on or near its intended track (route). It is assumed that detection may be aided by survivor signals or by electronic means. The track line pattern is also used for night searches (in suitable weather). A search aircraft using the track line pattern flies a rapid and reasonably thorough coverage on either side of the missing aircraft's intended track.

4. Search altitude for the track line pattern usually ranges from 1000 feet above ground level (AGL) to 2000 feet AGL for day searches, while night searches range 2000 to 3000 feet AGL (either depending upon light conditions and visibility). Lat/long coordinates for turns are determined and then entered into the GPS as waypoints, which may then be compiled into a flight plan.

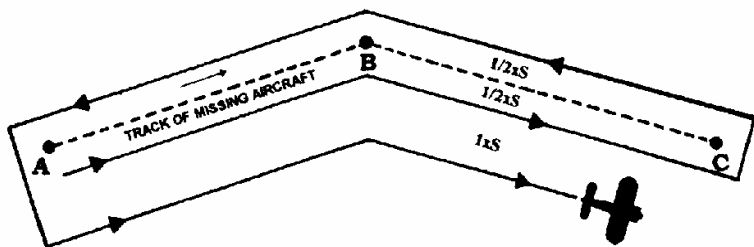

The search crew begins by flying parallel to the missing aircraft's intended course line, using the track spacing (labeled "S") determined by the incident commander or planning section chief. On the first pass, recommended spacing may be one-half that to be flown on successive passes. Flying one-half "S" track spacing in the area where the search objective is most likely to be found can increase search coverage.

5. You may use a worksheet to draw the route and to log coordinates and distinctive features. As a backup, note applicable VOR radials and cross-radials. The GX55 has a function called "parallel track offset" that is very handy for route searches. This function allows you to create a parallel course that is offset to the left or right (up to 20 nm) of your current flight plan. This function can also be useful on when you wish to search a 'corridor' of airspace.

Additional Information

Search patterns are covered in Tasks O-2102 thru O-2105 and may be combined in any fashion. More detailed information and figures on this topic are available in Chapter 11 of the MART.

Practice

Setup: Give the student a route search to plan and fly. The student should have a sectional chart, plotter, and worksheets as needed.

The route may be along a highway (to avoid straight lines) and should be of sufficient length (out and back) to allow the student time to demonstrate proficiency in all aspects of the search. Search altitude, airspeed and track spacing should be selected to match terrain and conditions: 1,000' to 2,000' AGL, 100 knots, and one mile track spacing is recommended.

Depending on the level of proficiency of the pilot, one or more of these tasks may be practiced simultaneously:

Planning. All mission sorties must be thoroughly planned: this ensures the pilot and crew can accomplish the sortie objectives safely and precisely. Treat each sortie as if it were an actual mission. Each time the student practices a sortie all required paperwork should be completed as part of the drill. The student should sign herself and the aircraft into the mission, receive her assignment from you (the briefing officer), plan the sortie, and complete the flight plan and preliminary mission data portions of the CAPF 104. Review the weight and balance, fuel assumptions, and information entered onto the CAPF 104 thoroughly.

Preflight and pilot briefings. Ensure the student performs a thorough preflight of the aircraft. Acting as a crewmember, receive pilot safety and mission briefings from the student. Perform safety assignments as directed by the student (e.g., collision avoidance during taxi and in flight).

Equipment. To the extent possible, the student should operate the communications and navigation equipment. The student should set up and enter information into the equipment (especially the GPS) prior to taxi. [Where necessary for safety or training, the training pilot should take over the aircraft controls while the student sets up navigation equipment (particularly the GPS) in flight.]

Initial training. Depending on the proficiency and skills of the student, the training pilot may need to demonstrate all aspects of a route search with the student sitting in the right seat. This gives the student time to absorb the information and work on such skills as setting up, entering data, and using the navigational equipment without the added responsibilities of the PIC.

For each practice sortie, watch for:

- 1) Proper setup of the navigational equipment, particularly the GPS. [Depending on whether or not the student has access to a GPS simulator, the training pilot may fly the aircraft while the student practices setting up and entering information into the GPS. However, by the time the student is ready for evaluation he must be able to fly the aircraft safely while accurately entering the required information into the GPS.]
- 2) Stabilized entry into the search area. The aircraft should be at search altitude and airspeed 3-5 miles before entering the search area.
- 3) Accurate and precise navigation. The student should maintain altitude, airspeed and track in the search area. Watch for proper wind drift correction and airspeed adjustments. Ensure the turns are started soon enough to stay inside the search area without requiring steeply banked turns (standard rate turns are preferred, but no more than 30° bank should be used). While the emphasis is on the use of the GPS, ensure the student can navigate using the VOR(s) or other means.
- 4) Safety. The student should spend most of her time looking outside the aircraft (see and avoid). Initially, the student will spend too much time with her eyes inside the aircraft (e.g., manipulating the GPS) until she is comfortable and proficient with the equipment. Get the student into the habit of *not looking inside the aircraft for more than five seconds at a time* to manipulate communications and navigational equipment.

Evaluation Preparation

Setup: Give the student a route search to plan and fly. The student should have a sectional chart, plotter, and worksheets as needed.

The route may be along a highway (to avoid straight lines) and should be of sufficient length (out and back) to allow the student time to demonstrate proficiency in all aspects of the search. Search altitude, airspeed and track spacing should be selected to match terrain and conditions: 1,000' to 2,000' AGL, 100 knots, and one mile track spacing is recommended.

Run the sortie as it would be during an actual mission. Have the student sign in, sign in the aircraft, and complete all required paperwork. Brief the sortie as if you were the Briefing Officer during a mission.

Brief Student: You are a Mission Pilot trainee asked to plan and fly a route search.

Evaluation

<u>Performance measures</u>	<u>Results</u>	
1. Sign yourself and your aircraft into the mission.	P	F
2. Receive a sortie briefing, asking questions as necessary.	P	F
3. Plan a route search from Point A to B and back. Include:		
a. Estimated time enroute and fuel requirements.	P	F
b. Position coordinates for the route (lat/long and VOR radials/cross-radials).	P	F
c. Altitude restrictions, obstacles and other hazards (e.g., MTRs and SUAs).	P	F
d. Discuss observer/scanner assignments for all possible combinations.	P	F
4. Fill out the flight plan and preliminary mission data on the CAPF 104.	P	F
5. Preflight the aircraft and perform pilot safety and mission briefings.	P	F
6. Demonstrate and discuss safety during each critical phase of the flight. In particular, demonstrate collision avoidance and enforce sterile cockpit rules.	P	F
7. Demonstrate proper ATC communications.	P	F
8. Setup the CAP FM radio and perform all required radio reports (may be simulated).	P	F
9. Perform the route search. Demonstrate:		
a. Proper use of nav aids (GPS as primary; VOR as backup).	P	F
b. Proper use of radios (ATC as required, and CAP FM radio reports).	P	F
c. Entry at the proper point, stabilized at search altitude and speed.	P	F
d. Accurate altitude and speed control in the search area.	P	F
e. Turns accomplished accurately using less than 30° bank angle.	P	F
f. Accurate navigation and track spacing.	P	F
g. Proper observer/scanner direction (may be simulated).	P	F
10. Demonstrate proper attention to fuel management.	P	F
11. Properly secure the aircraft at the end of the sortie (ready for next sortie).	P	F
12. Fill out the remainder of the CAPF 104 and debrief the sortie.	P	F

Student must receive a pass on all performance measures to qualify in this task. If the individual fails any measure, show what was done wrong and how to do it correctly.

O-2103
DEMONSTRATE PLANNING AND FLYING A PARALLEL TRACK SEARCH

CONDITIONS

You are a Mission Pilot trainee and must demonstrate how to plan and fly a parallel track search.

OBJECTIVES

Demonstrate how to plan and fly a parallel track search.

TRAINING AND EVALUATION

Training Outline

1. As a Mission Pilot trainee, the ability to plan and fly a parallel track search pattern is essential.
2. Parallel Track search pattern. The parallel track (sweep) search pattern is normally used when one or more of the following conditions exist: a) the search area is large and fairly level, b) only the approximate location of the target is known, or c) uniform coverage is desired. This type of search is used to search a grid.
3. The aircraft proceeds to a corner of the search area and flies at the assigned altitude, sweeping the area maintaining parallel tracks. The first track is at a distance equal to one-half (1/2) track spacing (S) from the side of the area.

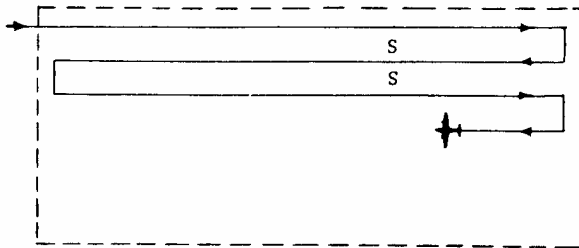

4. You may use a worksheet to draw the route and to log coordinates and distinctive features. As a backup, note applicable VOR radials and cross-radials. You can use this to enter the latitudes and longitudes that define the entry point and bound the grid, or to generate a flight plan.

Grid Coordinates

SECTIONAL: STL (N)S GRID# 104 A B C (E)
 ENTRY POINT: N 39°07.5' W 86°00'
 EXIT POINT: N 39°07.5' W 86°07'

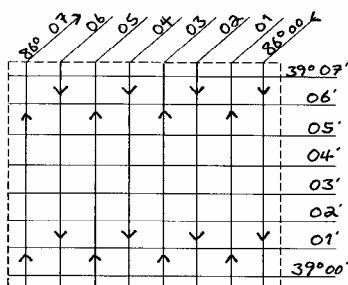

	NAVIGATIONAL AIDS	
IDENTIFIER	FREQUENCY	RADIAL
1. <u>OOM</u>	<u>110.2</u>	<u>090°</u>
2. <u>ABB</u>	<u>112.4</u>	<u>330°</u>

5. In the worksheet example, you will be searching STL Grid #104-D, which is a quarter-grid measuring 7.5' x 7.5'. Plot the grid's coordinates and draw the pattern starting at the entry point (northeast corner); include track spacing (one nm) and the direction of the legs (north/south). You will enter the entry point coordinates as a waypoint (N 39° 07' W 86° 00'; northeast corner). As you fly to the entry point, set up at search altitude and speed about 3-5 miles out.

You may fly the pattern using the GPS' continuous latitude/longitude display (e.g., present position). Remember, latitude increases as you go north; longitude increases as you go west. Even though you are using the GPS lat/long display, it's still helpful to note your headings for the legs (in the example, north and south). Once you have flown a couple of legs you will have two headings that you can shoot for that will correct for any wind; it's easier to use the heading indicator as your primary indicator and check your accuracy with the GPS. [Note: if you're not using your VOR heads, set the top OBS with one heading (e.g., north) and the lower OBS to the other heading -- use all available equipment.]

Also, always enter relevant VOR cross-radials onto your worksheet and use them as a backup and to verify important positions.

6. All the data you need set up this search pattern in the GX55 is on the worksheet:

- Type of Grid and Sectional (US grid, STL).
- Type of pattern (Parallel Line).
- Grid 104D2, where '2' indicates entering the northeast corner of D quadrant. *
- Spacing (1 nm).
- Direction of Travel (N/S).

* The GX-55 identifies the corners of quadrants by numbers: 1 = enter the NW corner; 2 = NE corner; 3 = SE corner; and 4 = SW corner. In our example you would enter "104D2."

Note: If you wish, record this data separately (e.g., a list or table) to make it even easier to enter into the GX-55. The example, above, has the data listed in the sequence that you enter into the GX-55.

Additional Information

Search patterns are covered in tasks O-2102 thru O-2105 and may be combined in any fashion. More detailed information and figures on this topic are available in Chapter 11 of the MART.

Practice

Setup: Give the student a one-quarter-grid search to plan and fly. The student should have a sectional chart, plotter, and worksheets as needed.

This search method is most often used inside a grid, and the student has to master several tasks in order to be proficient in flying a parallel track inside a grid.

Depending on the level of proficiency of the pilot, one or more of these tasks may be practiced simultaneously:

Planning. All mission sorties must be thoroughly planned: this ensures the pilot and crew can accomplish the sortie objectives safely and precisely. Treat each sortie as if it were an actual mission. Each time the student practices a sortie all required paperwork should be completed as part of the drill. The student should sign herself and the aircraft into the mission, receive her assignment from you (the briefing officer), plan the sortie, and complete the flight plan and preliminary mission data portions of the CAPF 104. Review the weight and balance, fuel assumptions, and information entered onto the CAPF 104 thoroughly.

Preflight and pilot briefings. Ensure the student performs a thorough preflight of the aircraft. Acting as a crewmember, receive pilot safety and mission briefings from the student. Perform safety assignments as directed by the student (e.g., collision avoidance during taxi and in flight).

Equipment. To the extent possible, the student should operate the communications and navigation equipment. The student should set up and enter information into the equipment (especially the GPS) prior to taxi. [Where necessary for safety or training, the training pilot should take over the aircraft controls while the student sets up navigation equipment (particularly the GPS) in flight.]

Initial training. Depending on the proficiency and skills of the student, the training pilot may need to demonstrate all aspects of a parallel track search with the student sitting in the right seat. This gives the student time to absorb the information and work on such skills as setting up, entering data, and using the navigational equipment without the added responsibilities of the PIC.

For each practice sortie, watch for:

- 1) Proper setup of the navigational equipment, particularly the GPS. [Depending on whether or not the student has access to a GPS simulator, the training pilot may fly the aircraft while the student practices setting up and entering information into the GPS. However, by the time the student is ready for evaluation he must be able to fly the aircraft safely while accurately entering the required information into the GPS.]
- 2) Stabilized entry into the search area. The aircraft should be at search altitude and airspeed 3-5 miles before entering the search area.
- 3) Accurate and precise navigation. The student should maintain altitude, airspeed and track in the search area. Watch for proper wind drift correction and airspeed adjustments. Ensure the turns are started soon enough to stay inside the search area without requiring steeply banked turns (standard rate turns are preferred, but no more than 30° bank should be used). While the emphasis is on the use of the GPS, ensure the student can navigate using the VOR(s) or other means.
- 4) Safety. The student should spend most of her time looking outside the aircraft (see and avoid). Initially, the student will spend too much time with her eyes inside the aircraft (e.g., manipulating the GPS) until she is comfortable and proficient with the equipment. Get the student into the habit of *not looking inside the aircraft for more than five seconds at a time* to manipulate communications and navigational equipment.

Evaluation Preparation

Setup: Give the student a one-quarter-grid search to plan and fly. The student should have a sectional chart, plotter, and worksheets as needed.

The student will enter and fly the grid using the parallel track search method long enough to demonstrate proficiency in all aspects of the search. Search altitude, airspeed and track spacing should be selected to match terrain and conditions: 1,000' AGL, 90 knots, and one mile track spacing is recommended.

Run the sortie as it would be during an actual mission. Have the student sign in, sign in the aircraft, and complete all required paperwork. Brief the sortie as if you were the Briefing Officer during a mission.

Brief Student: You are a Mission Pilot trainee asked to plan and fly a parallel track search of a grid.

Evaluation

<u>Performance measures</u>	<u>Results</u>	
1. Sign yourself and your aircraft into the mission.	P	F
2. Receive a sortie briefing, asking questions as necessary.	P	F
3. Plan a parallel track search of a grid. Include:		
a. Estimated time enroute, time in the grid, and fuel requirements.	P	F
b. Position coordinates for the entry and exit points (lat/long & VOR radials/cross-radials).	P	F
c. Position coordinates for the grid legs (lat/long and VOR radials/cross-radials).	P	F
d. Altitude restrictions, obstacles and other hazards (e.g., MTRs and SUAs).	P	F
e. Discuss observer/scanner assignments for all possible combinations.	P	F
4. Fill out the flight plan and preliminary mission data on the CAPF 104.	P	F
5. Preflight the aircraft and perform pilot safety and mission briefings.	P	F
6. Demonstrate and discuss safety during each critical phase of the flight. In particular, demonstrate collision avoidance and enforce sterile cockpit rules.	P	F
7. Demonstrate proper ATC communications.	P	F
8. Setup the CAP FM radio and perform all required radio reports (may be simulated).	P	F
9. Fly the grid search. Demonstrate:		
a. Proper use of nav aids (GPS as primary; VOR as backup).	P	F
b. Proper use of radios (ATC as required, and CAP FM radio reports).	P	F
c. Entry at the proper point, stabilized at search altitude and speed.	P	F
d. Accurate altitude and speed control inside the grid.	P	F
e. Turns accomplished accurately using less than 30° bank, and stays inside the grid.	P	F
f. Accurate navigation and track spacing.	P	F
g. Proper observer/scanner direction (may be simulated).	P	F
10. Demonstrate proper attention to fuel management.	P	F
11. Properly secure the aircraft at the end of the sortie (ready for next sortie).	P	F
12. Fill out the remainder of the CAPF 104 and debrief the sortie.	P	F

Student must receive a pass on all performance measures to qualify in this task. If the individual fails any measure, show what was done wrong and how to do it correctly.

5. In the worksheet example (above), assume you will be searching along a highway between two towns. Draw the pattern starting at the entry point; include track spacing (one nm) and make each leg extend three nm east and west of the highway. You will enter the entry point coordinates as a waypoint (N 39° 10' W 85° 53'). As you fly to the entry point, set up search altitude and airspeed three to five miles out, then fly the pattern using the GPS' continuous lat/long display. In this example, you will initially fly a constant latitude line of N 39° 10' until you reach W 85° 47' where you will turn right 180° and stabilize on a constant latitude line of N 39° 09'; repeat this process until the search is completed.

If the route is along a cardinal heading such as the highway example above, then the pilot will simply fly the creeping line using continuously displayed latitude and longitude. However, when the route is not a straight line aligned with a cardinal heading, another method may be used to fly a creeping line search pattern.

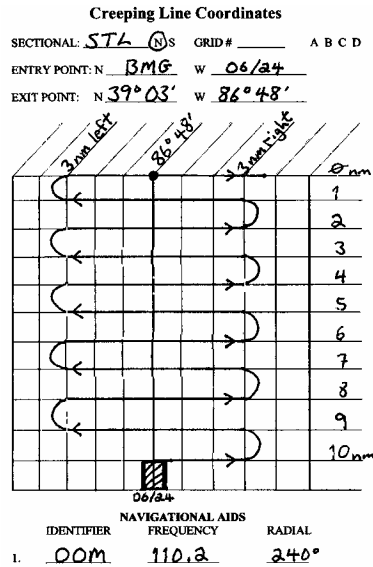

Assume that the aircraft will be flying a creeping line for ten miles southwest along an (imaginary) extended runway centerline (06/24 at BMG), and it is desired to fly three miles to either side of the extended runway centerline with one-mile track spacing. Draw the pattern starting at the entry point (Runway 06, BMG); include track spacing (one nm) and make each leg extend three miles either side of the extended centerline. In the right column enter the distance from the waypoint for each leg, starting at ten miles and counting down. Enter the exit point's lat/long (N 39° 03' W 86° 48'; ten miles southwest of the end of runway 06) in the GPS as a waypoint.

Enter the airport (BMG) as a destination and fly to it. Set the aircraft up at search altitude and airspeed three to five miles from the airport. Select the waypoint you created as your new destination.

When you fly over the end of Runway 06, zero (reset) the CDI display on the GPS. This sets up a *route* in the GPS that represents a direct line between the entry (end of runway 06) and exit points. The GPS should show ten miles to the destination, and the CDI will be centered.

Use the distance to the destination to establish and maintain one-mile track spacing; use the CDI deviation indication to indicate when you have gone three miles to either side of the line.

The pilot begins his first turn, for example to the right. By maintaining the distance from the destination constant (e.g., ten miles) the aircraft will be flying *almost* perpendicular to the extended runway centerline. Watch the CDI, which will begin showing that the aircraft is deviating from the intended route to the right. When the aircraft has deviated by almost three miles (the length of your right leg) the pilot will begin a turn to

the left. The turn will be completed so that the aircraft will now be flying in the opposite direction at a distance of nine miles from the destination (the one-mile track spacing).

Now watch the CDI begin to return to center while maintaining a constant nine-mile distance from the destination. Continue as the CDI begins to deviate to the left, and the next turn (to the right) will begin as you approach a three-mile deviation. Continue this pattern until you have completed your search.

Note: By using this technique you will actually be flying arcs instead of the usual squared (rectangular) legs. This is of little concern since the purpose is to cover the entire search area in a methodical manner.

This method is very handy when you are assigned a creeping line while airborne. It's easy to plan, set up and perform once you have mastered the technique.

You can also fly this pattern along a Victor airway. You can fly a similar pattern using the DME; it will be like flying a series of DME arcs.

This method can also be used along a winding river or a road, but the pilot must plan a line that roughly bisects the winding route and then vary the length of the legs as conditions warrant on the ground below.

6. In the GX55, the creeping line is similar to the parallel line pattern, but the starting point is a selected waypoint rather than a grid. The pattern will straddle the center of your flight plan. All the data you need set up this search pattern in the GX55 is on the worksheet:

- Type of Grid and Sectional (US grid, STL).
 - Type of pattern (Creeping Line).
 - Starting Waypoint (the airport, BMG).
 - Spacing (1 nm).
 - Direction of Travel (the runway heading, 060°).
 - Leg Length (3 nm *).
 - Start Side (Right).
- * 9.9 nm is the longest leg length you can select on the GX-55.

Additional Information

Search patterns are covered in tasks O-2102 thru O-2105 and may be combined in any fashion. More detailed information and figures on this topic are available in Chapter 11 of the MART.

Practice

Setup: Give the student a creeping line search to plan and fly. The student should have a sectional chart, plotter, and worksheets as needed.

Two kinds of creeping line searches should be practiced: one along a highway and the other along the imaginary extended centerline of an airport runway. The highway will demonstrate how to do a creeping line along a route with curves, where the student will have to make constant adjustments in order to ensure proper leg length. The extended runway centerline will demonstrate how to do a creeping line without regular ground references.

The student will enter and fly the pattern long enough to demonstrate proficiency in all aspects of the search. Search altitude, airspeed and track spacing should be selected to match terrain and conditions: 1,000' AGL, 90 knots, three mile legs, and one mile track spacing is recommended.

Depending on the level of proficiency of the pilot, one or more of these tasks may be practiced simultaneously:

Planning. All mission sorties must be thoroughly planned: this ensures the pilot and crew can accomplish the sortie objectives safely and precisely. Treat each sortie as if it were an actual mission. Each time the student practices a sortie all required paperwork should be completed as part of the drill. The student should sign herself and the aircraft into the mission, receive her assignment from you (the briefing officer), plan the sortie, and complete the flight plan and preliminary mission data portions of the CAPF 104. Review the weight and balance, fuel assumptions, and information entered onto the CAPF 104 thoroughly.

Preflight and pilot briefings. Ensure the student performs a thorough preflight of the aircraft. Acting as a crewmember, receive pilot safety and mission briefings from the student. Perform safety assignments as directed by the student (e.g., collision avoidance during taxi and in flight).

Equipment. To the extent possible, the student should operate the communications and navigation equipment. The student should set up and enter information into the equipment (especially the GPS) prior to taxi. [Where necessary for safety or training, the training pilot should take over the aircraft controls while the student sets up navigation equipment (particularly the GPS) in flight.]

Initial training. Depending on the proficiency and skills of the student, the training pilot may need to demonstrate all aspects of a creeping line search with the student sitting in the right seat. This gives the student time to absorb the information and work on such skills as setting up, entering data, and using the navigational equipment without the added responsibilities of the PIC.

For each practice sortie, watch for:

1) Proper setup of the navigational equipment, particularly the GPS. [Depending on whether or not the student has access to a GPS simulator, the training pilot may fly the aircraft while the student practices setting up and entering information into the GPS. However, by the time the student is ready for evaluation he must be able to fly the aircraft safely while accurately entering the required information into the GPS.]

2) Stabilized entry into the search area. The aircraft should be at search altitude and airspeed 3-5 miles before entering the search area.

3) Accurate and precise navigation. The student should maintain altitude, airspeed and track in the search area. Watch for proper wind drift correction and airspeed adjustments. Ensure the turns are started soon enough to stay inside the search area without requiring steeply banked turns (standard rate turns are preferred, but no more than 30° bank should be used). While the emphasis is on the use of the GPS, ensure the student can navigate using the VOR(s) or other means.

4) Safety. The student should spend most of her time looking outside the aircraft (see and avoid). Initially, the student will spend too much time with her eyes inside the aircraft (e.g., manipulating the GPS) until she is comfortable and proficient with the equipment. Get the student into the habit of *not looking inside the aircraft for more than five seconds at a time* to manipulate communications and navigational equipment.

Evaluation Preparation

Setup: Give the student a creeping line search to plan and fly. The student should have a sectional chart, plotter, and worksheets as needed.

The student will enter and fly the pattern long enough to demonstrate proficiency in all aspects of the search. Search altitude, airspeed and track spacing should be selected to match terrain and conditions: 1,000' AGL, 90 knots, three mile legs, and one mile track spacing is recommended.

Run the sortie as it would be during an actual mission. Have the student sign in, sign in the aircraft, and

complete all required paperwork. Brief the sortie as if you were the Briefing Officer during a mission.

Brief Student: You are a Mission Pilot trainee asked to plan and fly a creeping line search.

Evaluation

<u>Performance measures</u>	<u>Results</u>	
1. Sign yourself and your aircraft into the mission.	P	F
2. Receive a sortie briefing, asking questions as necessary.	P	F
3. Plan a creeping line search. Include:		
a. Estimated time enroute, time in the search area, and fuel requirements.	P	F
b. Position coordinates for the entry and exit points (lat/long & VOR radials/cross-radials).	P	F
c. Position coordinates for the legs (lat/long and VOR radials/cross-radials).	P	F
d. Altitude restrictions, obstacles and other hazards (e.g., MTRs and SUAs).	P	F
e. Discuss observer/scanner assignments for all possible combinations.	P	F
4. Fill out the flight plan and preliminary mission data on the CAPF 104.	P	F
5. Preflight the aircraft and perform pilot safety and mission briefings.	P	F
6. Demonstrate and discuss safety during each critical phase of the flight. In particular, demonstrate collision avoidance and enforce sterile cockpit rules.	P	F
7. Demonstrate proper ATC communications.	P	F
8. Setup the CAP FM radio and perform all required radio reports (may be simulated).	P	F
9. Fly the creeping line search. Demonstrate:		
a. Proper use of nav aids (GPS as primary; VOR as backup).	P	F
b. Proper use of radios (ATC as required, and CAP FM radio reports).	P	F
c. Entry at the proper point, stabilized at search altitude and speed.	P	F
d. Accurate altitude and speed control inside the search area.	P	F
e. Turns accomplished accurately using less than 30° bank angles.	P	F
f. Accurate navigation and track spacing.	P	F
g. Proper observer/scanner assignment (may be simulated).	P	F
10. Demonstrate proper attention to fuel management.	P	F
11. Properly secure the aircraft at the end of the sortie (ready for next sortie).	P	F
12. Fill out the remainder of the CAPF 104 and debrief the sortie.	P	F

Student must receive a pass on all performance measures to qualify in this task. If the individual fails any measure, show what was done wrong and how to do it correctly.

DEMONSTRATE PLANNING AND FLYING A POINT BASED SEARCH**CONDITIONS**

You are a Mission Pilot trainee and must demonstrate how to plan and fly point based searches.

OBJECTIVES

Demonstrate how to plan and fly an expanding square search.

TRAINING AND EVALUATION**Training Outline**

Point-based searches are organized around a point on the ground. These patterns are used when the approximate location of the target is known and are not intended to cover large areas. Examples are the expanding square, sector and circle search patterns.

1. Expanding Square search pattern. The expanding square search pattern is used when the search area is small (normally, areas less than 20 miles square), and the position of the survivors is known within close limits. This pattern begins at an initially reported position and expands outward in concentric squares. If error is expected in locating the reported position, or if the target were moving, the square pattern may be modified to an expanding rectangle with the longer legs running in the direction of the target's reported, or probable, movement.

If the results of the first square search of an area are negative, the search unit can use the same pattern to cover the area more thoroughly. The second search of the area should begin at the same point as the first search; however, the first leg of the second search is flown diagonally to the first leg of the first search. Consequently, the entire second search diagonally overlays the first one. The bold, unbroken line in the figure illustrates the first search, while the dashed line represents the second search. Track spacing indicated in the figure is "cumulative," showing the total width of the search pattern at a given point on that leg. Actual distance on a given leg from the preceding leg on the same side of the pattern is still only one "S," the value determined by the incident commander or planning section chief.

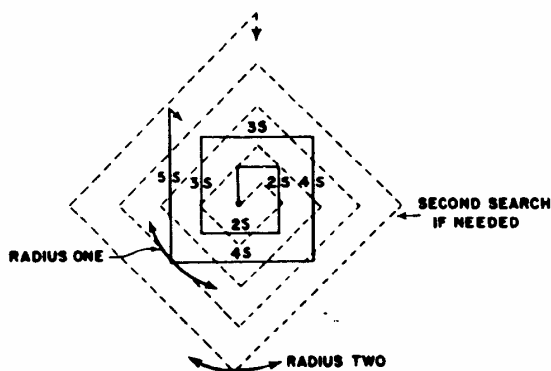

2. The GPS is used because this pattern requires precise navigation and is affected by wind drift. Even using the GPS, it is helpful for the pilot to orient the expanding square pattern along the cardinal headings to reduce confusion during turns. [Or, you can enter the pattern as a flight plan and it will direct your turns.]

3. You may use a worksheet to draw the pattern and to log coordinates and distinctive features. As a backup, note applicable VOR radials and cross-radials.

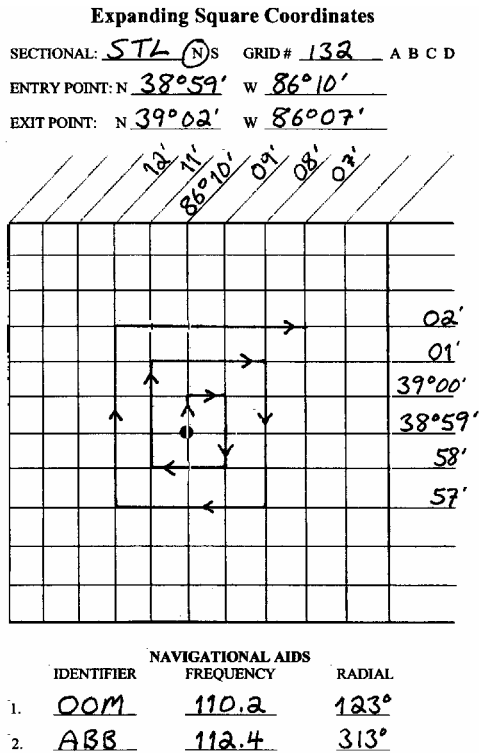

4. Fill the worksheet with the lat/longs that describe the expanding square. Starting at the entry point (e.g., a 483' AGL tower), draw the square by going one mile north, then one mile east, then two miles south, and so on. You set it up this way because it is best to fly the square by first flying due north and then making all subsequent turns to the right; right turns are used because they allow the observer and scanner(s) to see the ground during the turns. You use cardinal headings because they are easiest for the pilot to fly. Length and width of the pattern may be modified to suit the requirements and conditions of the individual search.

Enter the lat/long of the starting point (N 38° 59' W 86° 10') into the GPS and save it as a waypoint. As you fly to the entry point, the pilot should set up at search altitude and speed about 3-5 miles out (this ensures a stabilized entry so that you can begin searching immediately). The pilot should fly the pattern using the heading indicator and continuously displayed latitude and longitude on the GPS.

Note: If the aircraft doesn't have an operable GPS the first leg should be flown directly into or directly with the wind. Every other leg will thus be affected by the wind in a relatively consistent manner.

5. In the GX55, the expanding square will radiate from a starting waypoint according to the spacing between lines and at an angle selected by you. All the data you need set up this search pattern in the GX55 is on the worksheet:

- Type of Grid and Sectional (US grid, STL).
- Type of pattern (Expanding Square).
- Starting Waypoint (483' AGL tower, N 38° 59' W 86° 10').
- Spacing (1 nm).
- Direction of Travel (due north, 000°).

* 9.9 nm is the longest leg length you can select on the GX-55.

6. Sector search pattern. A sector search pattern is also best planned on the ground, as it involves multiple headings and precise leg lengths. The pilot will fly over the suspected location and out far enough to make a turn, fly a leg that is equal to the maximum track spacing, and then turn back to fly over the point again. This continues until the point has been crossed from all the angles.

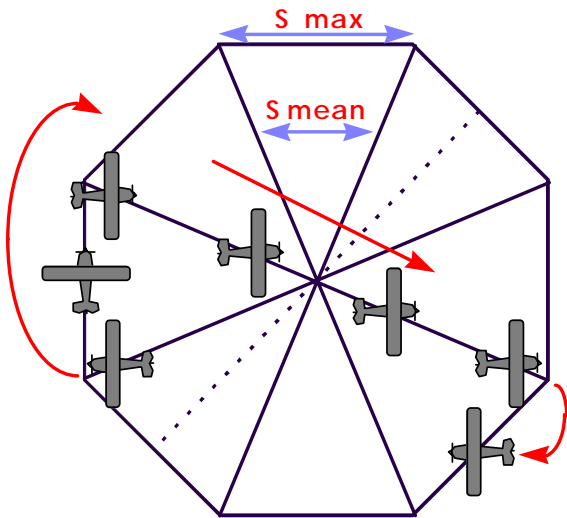

This search pattern provides concentrated coverage near the center of the search area and provides the opportunity to view the suspected area from many angles (this minimizes terrain and lighting problems).

7. Circle search pattern. A circle search pattern may be used when you have a prominent ground reference. The pilot executes a series of 'turns around a point' (circles of uniform distance from a ground reference point). Once the first circle is flown, the pilot moves outward by the desired track spacing and repeats the maneuver. This pattern is usually only used to cover a very small area, which is dependent upon search visibility (the pilot must be able to see the ground reference). Its benefit is that you only need to be able to locate and see the ground reference point, and no prior planning is needed. However, the pilot must constantly correct for the wind.

Additional Information

Search patterns are covered in tasks O-2102 thru O-2105 and may be combined in any fashion. More detailed information and figures on this topic are available in Chapter 11 of the MART.

Practice

Setup: Give the student an expanding square or sector search to plan and perform. The student should have a sectional chart, plotter, and worksheets as needed. A qualified Mission Pilot should be available to assist the trainee.

Brief the pilot. The pilot should fly the pattern long enough to allow the student time to demonstrate proficiency in all aspects of the search. Search altitude, airspeed and track spacing should be selected to match terrain and conditions: 1,000' to 2,000' AGL, 90 knots, and one mile track spacing is recommended.

Depending on the level of proficiency of the student, one or more of these tasks may be practiced simultaneously:

Planning. All mission sorties must be thoroughly planned: this ensures the pilot and crew can accomplish the sortie objectives safely and precisely. Treat each sortie as if it were an actual mission. Each time the student practices a sortie all required paperwork should be completed as part of the drill. The student should sign

herself into the mission, ensure that the pilot signs in the aircraft, receive her assignment from you (the briefing officer), plan the sortie, and assist the pilot in completing the flight plan and preliminary mission data portions of the CAPF 104.

The pilot should review the weight and balance, fuel assumptions, and information entered onto the CAPF 104 with the student.

Preflight and pilot briefings. Ensure the student receives pilot safety and mission briefings from the pilot. The student will perform safety assignments as directed (e.g., collision avoidance during taxi and in flight).

Equipment. To the extent possible, the student should operate the communications and navigation equipment. The student should set up and enter information into the equipment (especially the GPS) prior to taxi. [Where necessary for training, the trainer should assist the student in setting up navigation equipment (particularly the GPS) in flight.]

Initial training. Depending on the proficiency and skills of the student, the trainer may need to demonstrate all aspects of a point-based search. This gives the student time to absorb the information and work on such skills as setting up, entering data, and using the navigational equipment.

For each practice sortie, watch for:

1) Proper setup and use of the navigational equipment, particularly the GPS. Ensure that the student does not change any navigational or communications equipment setting without the knowledge of the PIC.

2) Proper ATC and CAP FM communications technique and terminology. Initially, have the student tell the pilot and/or trainer what she intends to say *before* she transmits.

3) Proper and attentive collision avoidance practices during the critical phases of flight.

4) Safety. The student should spend most of her time looking outside the aircraft (see and avoid) when enroute to the search area, and most of her time acting as a scanner while in the search area. Initially, the student will spend too much time with her eyes inside the aircraft (e.g., manipulating the GPS) until she is comfortable and proficient with the equipment. Get the student into the habit of *not looking inside the aircraft for more than five seconds at a time* to manipulate communications and navigational equipment.

5) Accurate situational awareness at all times.

Evaluation Preparation

Setup: Give the student an expanding square or sector search to plan and perform. The student should have a sectional chart, plotter, and worksheets as needed. A qualified Mission Pilot should be available to assist the trainee during the planning and flying stages.

A search target should be positioned in the search area, if possible.

The pilot will enter and fly the pattern long enough to allow the student to demonstrate proficiency in all aspects of the search. Search altitude, airspeed and track spacing should be selected to match terrain and conditions: 1,000' AGL, 90 knots, three mile legs, and one mile track spacing is recommended.

Run the sortie as it would be during an actual mission. Have the student sign in, sign in the aircraft, and complete all required paperwork. Brief the sortie as if you were the Briefing Officer during a mission.

Brief Student: You are a Mission Observer trainee asked to assist a Mission Pilot in planning and performing a point-based search.

Evaluation

<u>Performance measures</u>	<u>Results</u>	
1. Sign into the mission.	P	F
2. Receive a sortie briefing, asking questions as necessary.	P	F
3. Assist in planning a point-based search (expanding square or sector). Include:		
a. Estimated time en route, time in the search area, and fuel requirements.	P	F
b. Position coordinates for the entry and exit points (lat/long & VOR radials/cross-radials).	P	F
c. Position coordinates for the legs (lat/long and VOR radials/cross-radials).	P	F
d. Altitude restrictions, obstacles and other hazards (e.g., MTRs and SUAs).	P	F
e. Discuss observer/scanner assignments for all possible combinations.	P	F
4. Assist in filling out the flight plan and preliminary mission data on the CAPF 104.	P	F
5. Receive pilot safety and mission briefings, asking questions as necessary.	P	F
6. Demonstrate and discuss safety during each critical phase of the flight. In particular, demonstrate collision avoidance and enforce sterile cockpit rules.	P	F
7. Demonstrate proper ATC communications.	P	F
8. Setup the CAP FM radio and perform all required radio reports (may be simulated).	P	F
9. Perform the point-based search (expanding square or sector). Demonstrate:		
a. Proper use of nav aids (GPS as primary; VOR as backup).	P	F
b. Proper use of radios (ATC as required, and CAP FM radio reports).	P	F
c. Proper scanner assignment (may be simulated).	P	F
d. Ability to spot the search target (if applicable).	P	F
10. Demonstrate proper attention to fuel management.	P	F
11. Ensure the aircraft is secured at the end of the sortie (ready for next sortie).	P	F
12. Assist in filling out the remainder of the CAPF 104 and debrief the sortie.	P	F

Student must receive a pass on all performance measures to qualify in this task. If the individual fails any measure, show what was done wrong and how to do it correctly.

O-2106
PLAN AND COMMAND A CAP FLIGHT

CONDITIONS

You are a Mission Pilot trainee and must plan and command a CAP flight.

OBJECTIVES

Plan and command a CAP flight. Perform preflight tasks and briefings, check and fill out applicable aircraft logs, perform briefings for all critical phases of flight, and perform after-landing tasks.

TRAINING AND EVALUATION

Training Outline

1. As a Mission Pilot trainee, knowing the mission pilot's responsibilities during each phase of flight so as to command the flight is essential. In all cases follow the aircraft checklists: the observer should read each item to you and then you will perform the item and repeat back performance of the item.

2. *Prior to Startup*

One of the most overlooked assets you have in the aircraft is the glove box. This area is ideal for items such as small, laminated sheets for the crew and passenger briefing, crosswind chart, public relations cards (like those from the CD program), FM radio frequencies and callsigns, ELT deactivation stickers, and a GPS cheat-sheet. Other items could include a small cleaning rag (like for glasses) to clean the GPS display and a backup flashlight. Check the glove box periodically and purge unnecessary stuff.

For every CAP flight the PIC must ensure the crew is wearing a proper CAP uniform (CAPM 39-1) and is carrying a current CAP Membership card. For non-CAP passengers, refer to CAPR 60-1.

- a. After you have obtained a flight release, fill in all required information on the aircraft Flight Log. Ensure proper entries for mission symbol, mission number, crew names, and FRO name.
- b. It is important for the mission pilot to understand how to find data in aircraft logbooks. Familiarize yourself with your aircraft's engine, propeller, airframe, and avionics logbooks so that you can identify items such as the time of the last mid-cycle oil change (40-60 hours, not to exceed four months), last 100-hour inspection or annual, and instrument requirements (i.e., ELT battery, pitot-static system, transponder and altimeter current). Also, check other items such as the expiration dates on the carbon monoxide detector and fire extinguisher, and the date of the last VOR check.
- c. Check the Discrepancy and Maintenance Logs to ensure the aircraft is airworthy and mission ready. When you preflight, verify these discrepancies; if you find a new discrepancy, log it and assess airworthiness and mission readiness. [Document and Minimum Equipment requirements are in the *Flight Guide*.]
- d. Perform a Weight & Balance and determine fuel assumptions (e.g., fuel burn, winds, power setting, and distance) and reserve (CAPR 60-1 requires a minimum of one hour of fuel remaining upon landing, computed at normal POH/AFM cruise fuel consumption).
- e. During loading, ensure that all supplies and equipment correspond to what you used in your Weight & Balance.
- f. Ensure your aeronautical charts are current.
- g. Make sure the parking area is clear of obstacles; arrange for a wing-walker if one will be needed to clear obstacles.

3. *Engine Startup and Taxi*

Aircraft checklists

- a. *Always* use checklists in CAP aircraft. Whenever possible, have the right-seat crewmember read the checklist items to you while you check the items and repeat back accomplishment of each item.
- b. Make sure you or the right-seat crewmember keeps the checklist close at hand so that it can quickly be opened to confirm and complete emergency items. Brief the right-seat crewmember on how to use the emergency checklists (e.g., read the bold face items first and then continue with the rest of the items).
- c. Perform the passenger briefing, brief fuel assumptions, and brief crewmembers on taxi, takeoff and departure assignments, and enter navaid settings (e.g., GPS destination or flight plan).
- d. All crewmembers must wear their seat belts at all times. Although CAPR 60-1 only requires that the shoulder harness be worn at or below 1000' AGL, but all crewmembers should wear them at all times unless other duties require their removal (e.g., observer taking photos).

Startup

- a. Turn the Rotating Beacon ON and signal the marshaller before starting the engine.
- b. Include the DF unit's Alarm light self-test in your scan during startup. The light should blink for several seconds; if it doesn't your unit may be inoperative. Also ensure the Audio Panel and FM radio are set up properly (normally, the DF is set in the 'Alarm' mode).
- c. When >3000' DA (typical Cessna), lean the engine immediately after starting and for maximum power before takeoff.
- d. Obtain ATIS and Clearance (read back all clearances and hold-short instructions). Then verify you are within the Crosswind Limitation. For VFR in Class G airspace, you must have 3 statute miles visibility (unless you are current IFR; if this is an IFR flight, verify weather is at or above landing minimums and check that a VOR check was performed within the last 30 days).
- e. Remember to check your brakes as you begin your roll.

Taxi

- a. Review crew assignments for taxi, takeoff and departure. Make sure each crewmember knows in which direction they should be looking.
- b. Once you begin taxiing *the sterile cockpit rules begin; all unnecessary talk is suspended and collision avoidance becomes the priority of each crewmember*. Sterile cockpit rules focus each crewmember on the duties at hand, namely concentrating on looking outside the aircraft for obstacles and other aircraft. The rules will *always* be used during the taxi, takeoff, departure, approach, and landing phases of flight; but the pilot or observer may declare these rules in effect whenever they are needed to minimize distractions.
- c. Follow CAPR 60-1 requirements for taxi operations (taxi no faster than a slow walk when within 10 feet of obstacles; and maintain at least 50' behind light single-engine aircraft, 100' behind small multi-engine and jet aircraft, and 500' behind heavies and taxiing helicopters). Remember to read back all clearances and hold-short instructions.

4. *Takeoff, climb and departure*

Takeoff

- a. Ensure you are within crosswind limits of the aircraft's POH (or the CAP limit of 15 knots if none is given in the POH).
- b. *Remind the crew that midair collisions are most likely to occur in daylight VFR conditions within five miles of an airport at or below 3,000' AGL!* This means that most midair collisions occur in the traffic pattern. Since the pilot has only one set of eyes, this (and aircraft design) leaves several 'blind spots' that the observer and scanner must cover -- particularly between your 4 and 8 o'clock positions.
- c. *Always* look for landing traffic before taking the active runway!

- d. The FAA's "operation lights on" encourages pilots to keep aircraft lights on when operating within 10 miles of an airport, or wherever flocks of birds may be expected.

Climb

- a. Make shallow S-turns and lift your wing before turns when climbing to increase your chances of spotting conflicting aircraft.
- b. Keep your emergency checklist close at hand and open to the Emergency Procedures section.

Departure

- a. Collision avoidance! Maintain sterile cockpit until well clear of traffic and obstacles and keep the crew appraised of conflicting traffic and obstacles. When above 1000' AGL the crewmembers can remove shoulder harnesses but it is best to leave them fastened unless it interferes with a task (e.g., video sortie).
- b. Lean the engine (burn gas, not valves). For a typical C172 with an EGT: For economy setting, lean to peak EGT then richen 50 degrees rich-of-peak; for max continuous power, lean to peak EGT then richen 100 degrees rich-of-peak.
- c. Update fuel assumptions and set the altimeter to the closest source at least hourly.
- d. Maintain situational awareness.

5. Approach, descent and landing

Approach

- a. Obtain ATIS/AWOS and contact approach control. Review the taxi plan/diagram and make crew assignments for approach, landing and taxi. *Sterile cockpit rules are now in effect.*
- b. Collision avoidance! Lights on within 10 miles of the airport. Read back all landing and hold-short instructions.
- c. *Remind the crew that midair collisions are most likely to occur in daylight VFR conditions within five miles of an airport (especially non-towered airports) at or below 3,000' AGL! This means that most midair collisions occur in the traffic pattern, particularly on final approach.*

Descent

- a. Richen the fuel mixture during descents and don't shock-cool the engine. A well planned, partial power, mixture rich, cowl flaps closed descent is best.
- b. Enhance collision avoidance by making shallow S-turns and lifting your wing before turns during descent to check for traffic.

Landing, shutdown and post-flight

- a. It is recommended practice not to use the brakes during normal landings; a well-executed approach and landing allows you to roll out and taxi off the runway without the need for braking. Save the brakes for short-field landings and emergencies.
- b. Defer the after-landing check until the airplane is brought to a complete stop clear of the active runway (minimizes distractions).
- c. Fill in all remaining information on the aircraft flight log. Double-check entries for mission symbol, mission number, crew names, and FRO name. Enter any new problems into the Discrepancy log.
- c. If this was the last flight of the day install chocks, tie-downs, Avionics/control lock, and Pitot tube covers/engine plugs.
- d. Check that the Master Switch and Parking Brake is OFF and that the Fuel Selector Switch is in the 'Right' or 'Left' position for refueling. Remove any trash and personal equipment from the aircraft. Lock the aircraft windows, doors and baggage compartment.
- e. Check the general condition of the aircraft, check the oil, and refuel. Clean the leading edges and the windshield and windows and replenish cleaning supplies, if necessary.

Additional Information

More detailed information on this topic is available in FAR 91 Subpart C, CAPRs 60-1 and 66-1, and Chapter 12 of the MART. A "Mission Checklist" in Attachment 2 of the MART summarizes the steps in this task guide.

Practice

Setup: Give the student a flight to plan and fly. The flight should include planning to land at an unfamiliar airport in controlled airspace -- Class B, if practical and be of sufficient length to force the student to plan a refueling stop. The student should have access to CAP regulations and forms and aircraft logs.

The student will fly long enough to demonstrate proficiency in all aspects of the flight. Flight altitude and airspeed should be selected to match the local practice area.

The trainer should play the role of an aircrew member, particularly for receiving briefings and instructions from the mission pilot trainee.

Depending on the level of proficiency of the pilot, one or more of these tasks may be practiced simultaneously:

Planning. All CAP flights must be thoroughly planned: this ensures the pilot and crew can accomplish the flight safely. Each time the student practices a flight all required paperwork should be completed as part of the drill. Review the weight and balance and fuel assumptions thoroughly.

Preflight and crew briefings. Ensure the student performs a thorough preflight of the aircraft. Acting as a crewmember, receive pilot safety and crew briefings from the student. Perform safety assignments as directed by the student (e.g., collision avoidance during taxi and in flight).

Equipment. To the extent possible, the student should operate the communications and navigation equipment. The student should set up and enter information into the equipment (especially the GPS) prior to taxi. [Where necessary for safety or training, the training pilot should take over the aircraft controls while the student sets up navigation equipment (particularly the GPS) in flight.]

For this flight, watch for:

- 1) Thorough knowledge of aircraft and CAP regulations, logs and paperwork.
- 2) Proper use of checklists during all phases of flight.
- 3) Accurate and thorough planning for all phases of flight (e.g., taxiways and airspace restrictions).
- 4) Thorough briefings to the crew during all phases of flight.
- 5) Proper use of sterile cockpit rules and collision avoidance techniques (e.g., safe taxiing, observing airport signs, reading back ATC instructions, and S-turns to look for traffic during climb and descent).
- 6) Situational awareness and proper attention to fuel status and altimeter settings.
- 7) Proper shutdown, inspection, securing and cleaning of the aircraft after flight.

Evaluation Preparation

Setup: Give the student a flight to plan and fly. The flight should include planning to land at an unfamiliar airport in controlled airspace -- Class B, if practical, and should be of sufficient length to force the student to plan a refueling stop (this won't be performed). The student should have access to CAP regulations and forms and aircraft logs.

The student will fly long enough to demonstrate proficiency in all aspects of the flight. Flight altitude and airspeed should be selected to match the local practice area.

The trainer should play the role of an aircrew member, particularly for receiving briefings and instructions from the trainee. Whenever flight safety allows, act as an inexperienced observer to force the pilot to do most of the work (e.g., setting up radios and nav aids and talking on the aircraft radio).

Brief Student: You are a Mission Pilot trainee asked to plan and fly a CAP flight.

Evaluation

<u>Performance measures</u>	<u>Results</u>	
1. Compute Weight & Balance, list fuel requirements and state fuel reserve.	P	F
2. Receive a briefing and obtain a flight release.	P	F
3. Prior to the flight:		
a. Referring to the aircraft log books, identify last mid-cycle oil change, last 100-hour inspection and annual, instrument requirements (i.e., ELT battery, pitot-static system, transponder and altimeter current), expiration dates on the CO detector and fire extinguisher, and the date of the last VOR check.	P	F
b. Identify outstanding squawks in the Discrepancy Log.	P	F
c. Identify minimum equipment for VFR (day & night) and IFR.	P	F
4. During aircraft preflight:		
a. Verify outstanding squawks.	P	F
b. Dispose of sumped fuel properly.	P	F
c. Clean windows, as necessary.	P	F
5. Prior to startup:		
a. Fill in Aircraft Log, and state time left to oil change and annual.	P	F
b. Perform passenger and crew briefings, and assign responsibilities.	P	F
c. Determine crosswind and state crosswind limit.	P	F
6. During startup:		
a. Turn rotating beacon ON before starting engine.	P	F
b. Setup the DF, Audio Panel and FM radio.	P	F
7. During taxi, takeoff, departure, approach, decent and landing:		
a. Demonstrate challenge-response method for checklists.	P	F
b. Demonstrate proper collision avoidance and taxi procedures.	P	F
c. Read back all ATC clearances (including hold-short directions).	P	F

- d. State and enforce sterile cockpit rules. P F
- e. Maintains situational awareness at all times. P F
- f. Demonstrate proper attention to fuel status and altimeter setting. P F
- 8. After landing:
 - a. Fill out the Aircraft Log and enter discrepancies (if necessary). P F
 - b. Properly shutdown, inspect, secure and clean the aircraft (as if last flight of the day). P F

Student must receive a pass on all performance measures to qualify in this task. If the individual fails any measure, show what was done wrong and how to do it correctly.

PREPARE FOR A TRIP TO A REMOTE MISSION BASE

CONDITIONS

You are a Mission Observer trainee and must prepare for a trip to a remote mission base.

OBJECTIVES

Prepare for a trip to a remote mission base, acting as mission commander. Assist in performing pre-trip planning and inspections, preflight tasks and briefings, filling out a CAP flight plan, and after-landing tasks.

TRAINING AND EVALUATION

Training Outline

1. As a Mission Observer trainee, the ability to prepare for a trip to a remote mission base is essential.
2. *Before you leave.* The urgency of events, coupled with a hasty call-out, may leave you and other crewmembers feeling rushed as you prepare to leave for a mission. This is where a good pre-mission checklist comes in handy. As a minimum, check the crew (and yourself) for the following:
 - A. Proper uniforms (CAPM 39-1) and credentials
 - 1) CAP Membership
 - 2) CAP Motor Vehicle Operator
 - 3) ROA
 - 4) 101/101T (note experience and tasks to be accomplished)
 - 5) Ensure the pilot has necessary credentials (e.g., license, medical, and photo ID)
 - B. Check personal equipment
 - 1) Clothing sufficient and suitable for the entire trip
 - 2) Personal supplies (civilian clothing, headset, charts, maps, plotter, log, checklists, fluids and snacks)
 - 3) Personal survival equipment (in addition to the aircraft kit) suitable for the entire trip
 - 4) Sufficient money for the trip (credit cards, some cash or traveler's checks, and coin)
 - 5) Cell phone (including spare battery and charger)
 - C. Check aircraft equipment
 - 1) Current aeronautical charts for the entire trip, and gridded charts for the mission area
 - 2) Maps for the mission area (e.g., road atlas, county maps, topo maps), plus clipboard and markers
 - 3) Tie-downs, chocks, Pitot tube cover and engine plugs, fuel tester, sick sacks, and cleaning gear
 - 4) Survival kit (fits trip and mission area terrain), headsets, flashlight, binoculars and multitool
 - D. Ensure the pilot reviews the Aircraft Logs
 - 1) Note the date and the starting Tach and Hobbs times to ensure you won't exceed:
 - a) Mid-cycle oil change (40-60 hours, not to exceed four months)
 - b) 100-hour/Annual
 - c) 24-month checks (Transponder, Pitot-Static system, Altimeter and ELT/battery replacement date)
 - d) 30-day VOR check for IFR flight and AD compliance list.
 - 2) Check the status of the Carbon Monoxide Detector and Fire Extinguisher
 - 3) Pilot reviews the Discrepancy Log and makes sure the aircraft is airworthy and mission ready
 - E. Pilot obtains FAA Weather Briefing and CAP Flight Release
 - 1) Perform Weight & Balance (reflecting weights for the crew, special equipment and baggage)
 - a) Include fuel assumptions (fuel burn, winds, power setting, distance, and fuel stop)
 - b) Ensure fuel reserve (land with one hour's fuel, computed at normal cruise)
 - 2) Verify within flight time and duty limitations (CAPR 60-1, Chapter 2)
 - 3) Obtain FAA briefing (ask for FDC and Local NOTAMs and SUA status) and file FAA Flight Plan

- a) Enter 'CPF XXXX' in the Aircraft Identification section
 - b) Put the 'N' and 'Cap Flight' numbers in the Remarks section
 - 4) Assist in filling out an "Inbound" CAPF 104 or 84 (leave copy for FRO)
 - 5) Pilot briefs the crew on the fuel management plan (assumptions, refueling stops, and reserve), Local and FDC NOTAMs, and SUA status
 - 6) Review "IMSAFE" and pilot obtains a CAP Flight Release
 - 7) Pilot requests Flight Following
- F. Pilot preflight
- 1) Ensure proper entries in the Flight Log (e.g., mission number & symbol, crew & FRO names)
 - 2) Check starting Tach and Hobbs times to ensure you won't exceed limits (e.g., oil change)
 - 3) Review the Discrepancy Log and make sure the aircraft is airworthy and mission ready
 - 4) While preflighting, verify any outstanding discrepancies. If new discrepancies discovered, log them and ensure the aircraft is still airworthy and mission ready. [Be extra thorough on unfamiliar aircraft.]
 - 5) Verify load is per your Weight & Balance (baggage, survival kit, extra equipment and luggage)
 - 6) Double-check aeronautical charts, maps and gridded charts (also clipboard and markers)
 - 7) Ensure required aids onboard (Flight Guide, distress and air-to-ground signals, fuel tester, tools)
 - 8) Windshield and windows clean, and chocks, tie-downs, Pitot tube covers and engine plugs stowed
 - 9) Right Window holding screw removed (video imaging mission) and stored
 - 10) Check and test special equipment (cameras, camcorder, slow-scan, repeater), including spare batteries
 - 11) Parking area clear of obstacles (arrange for a wing-walker if one will be needed to clear obstacles)
 - 12) Perform passenger briefing and review emergency egress procedure
 - 13) Review taxi plan/diagram and brief crew assignments for taxi, takeoff and departure
 - 14) Remind crew that most midair collisions occur in or near the traffic pattern
 - 15) Enter settings into GPS (e.g., destination or flight plan)
 - 16) Organize the cockpit
- G. Startup and Taxi
- 1) Pilot briefs checklist method to be used (e.g., challenge-response)
 - 2) Seat belts at all times; shoulder harness at or below 1000' AGL
 - 3) Double-check Intercom, Audio Panel and Comm Radio settings
 - 4) Rotating Beacon Switch ON and pilot signals marshaller before starting engine; lean for taxi
 - 5) Ensure DF and FM Radio are operable and set properly (FM radio check if first flight)
 - 6) Select initial VOR radial(s) and GPS setting
 - 7) Obtain ATIS and Clearance (read back all clearances and hold-short instructions)
 - 8) Pilot computes crosswind and verify within Crosswind Limitation
 - 9) Verify 3 statute miles visibility (VFR in Class G - unless PIC is current IFR)
 - 10) If IFR, verify weather at or above landing minimums and date of last VOR check
 - 11) Begin sterile cockpit
 - 12) Pilot signals marshaller before taxiing; checks brakes at beginning of roll
 - 13) Pilot taxis no faster than a slow walk when within 10 feet of obstacles
 - a) Maintains at least 50' behind light single-engine aircraft
 - b) Maintains at least 100' behind small multi-engine and jet aircraft
 - c) Maintains at least 500' behind heavies and taxiing helicopters
- H. Takeoff, Climb and Departure
- 1) Pilot double-checks assigned departure heading and altitude
 - 2) Pilot leans engine for full power (> 3000' DA)
 - 3) Look for landing traffic before taking the active runway
 - 4) Keep lights on within 10 miles of the airport and when birds reported nearby
 - 5) Begin Observer Log with takeoff (time and Hobbs) and report "Wheels Up"
 - 6) Pilot uses shallow S-turns and lifts wing before turns during climbing to check for traffic
 - 7) Keep shoulder harnesses buckled (never remove at or below 1000' AGL)
 - 8) Keep crew apprised of conflicting aircraft and obstacle positions

9) Keep checklists close at hand and open to Emergency Procedures

I Enroute

- 1) Maintain situational awareness
- 2) Pilot leans engine for economy cruise
- 3) Ensure pilot updates fuel assumptions and sets altimeter to closest source at least hourly

J Approach, Descent and Landing

- 1) Pilot plans approach and descent (remembers fuel mixture and cooling)
- 2) Double-checks radio and navigational settings
- 3) Obtain ATIS/AWOS and contact approach control
- 4) Review taxi plan/diagram and brief crew assignments for approach, landing and taxi
- 5) Remind crew that most midair collisions occur in or near the traffic pattern, especially on final
- 6) Begin sterile cockpit
- 7) Turn lights on within 10 miles of the airport
- 8) Pilot double-checks assigned approach heading and altitude
- 9) Pilot uses shallow S-turns and lifts wing before turns during descent to check for traffic
- 10) Read back all clearances and hold-short instructions
- 11) Log (time and Hobbs) and report "Wheels Down"

3. *Arrival at mission base*

A. Park and Secure Aircraft

- 1) Look for marshallsers, follow taxi plan, pilot signals marshaller that ignition is OFF
- 2) Double-check Master Switch OFF
- 3) Fuel Selector Switch to Right or Left (refueling)
- 4) Avionics/control Lock and Pitot tube covers/engine plugs installed
- 5) Pilot completes the Flight Log and enters squawks in Discrepancy Log
- 6) Chocks and Tie-downs installed and Parking Brake OFF
- 7) Remove trash and personal supplies/equipment
- 8) Lock the windows, doors and baggage compartment
- 9) Check oil and arrange for refueling
- 10) Clean leading edges, windshield, and windows
- 11) Replenish cleaning kit

B. Check in with Flight Line Supervisor and Safety Officer

C. Close FAA Flight Plan, call FRO

D. Sign personnel and aircraft into the mission (Administration)

E. Assist in completing and submitting 'Inbound 104' (keep a copy)

F. Report any special equipment to Logistics (cameras, camcorder, slow-scan, repeater)

G. Inquire about fuel billing, lodging, transportation and meals

H. Note time to report for duty and ask for sortie assignment (get briefing packet)

The mission staff will probably show you around mission base and inform you of transportation, lodging and meal arrangements. They will also tell you when to report for duty, normally by telling you when the general briefing will be held.

Additional Information

More detailed information and figures on this topic are available in Chapter 13 and Attachment 2 of the MART.

Practice

Setup: Give the student an assignment to go to a remote mission base. The base should be located on a large (unfamiliar) airport in controlled airspace -- Class B, if practical. The student should have access to mission materials and a CAPF 104.

The student will assist in planning a simulated a trip to a remote mission base. All tasks that can be performed will not be simulated.

The trainer should play the role of the mission pilot, particularly for performing inspections and giving briefings and instructions to the observer trainee. The observer will be given preflight and pilot briefings.

For this simulated sortie, watch for:

- 1) Thorough knowledge of documents and equipment required for an extended stay at a remote base.
- 2) Assists pilot in completion of the CAP flight plan.
- 3) Assists pilot with accurate and thorough planning for the trip.
- 4) Proper actions upon arrival at mission base.

Evaluation Preparation

Setup: Give the student an assignment to go to a remote mission base. The base should be located on a large (unfamiliar) airport in controlled airspace -- Class B, if practical. The student should have access to mission materials and a CAPF 104.

The student will assist in planning a simulated a trip to a remote mission base. All tasks that can be performed will not be simulated.

The trainer should play the role of the mission pilot, particularly for performing inspections and giving briefings and instructions to the observer trainee. The observer will be given preflight and pilot briefings.

Brief Student: You are a Mission Observer trainee asked to prepare for a trip to a remote mission base.

Evaluation

<u>Performance measures</u>	<u>Results</u>
1. Check for proper uniform, credentials and equipment.	P F
2. State the flight time and duty limitations per CAPR 60-1.	P F
3. Assist in checking the aircraft:	
a. Check for required equipment on board (e.g., tie downs, survival kit, cleaning gear).	P F
b. Clean windows, as necessary.	P F
4. Assist in filling out a CAP flight plan.	P F
5. Receive a briefing from the mission pilot:	
a. Fuel assumptions and fuel stop.	P F
b. Airspace restrictions, NOTAMS, and destination airport diagrams.	P F
6. Upon (simulated) arrival at mission base:	

- a. Secure the aircraft and arrange for refueling. P F
- b. Sign yourself and the aircraft into the mission. P F
- c. Assist in completing your "Inbound" CAPF 104. P F

Student must receive a pass on all performance measures to qualify in this task. If the individual fails any measure, show what was done wrong and how to do it correctly.

O-2108
PERFORM ELT SEARCHES

CONDITIONS

You are a Mission Observer trainee and must perform ELT searches.

OBJECTIVES

Assist the mission pilot in locating an Emergency Locator Transmitter (practice beacon) using the homing and wing null ELT search methods. Discuss the aural and metered search methods, and reflection and interference.

TRAINING AND EVALUATION

Training Outline

1. As a Mission Observer trainee, knowing how to plan for and locate an Emergency Locator Transmitter (ELT) is essential. There are several methods that can be used, the most common of which are the homing and wing null methods. You should also be familiar the aural and metered search method, and how reflections and signal interference can affect the search.

2. *Homing* is an electronic search method that uses the Direction Finder (DF) to track the ELT signal to its source. Tune the direction finder (DF) to the ELT operating frequency; the pilot will fly the aircraft to the transmitter. ELT's may transmit on either 121.5 MHz VHF, 243.0 MHz UHF, or both frequencies simultaneously. These emergency frequencies are *usually* the ones monitored during a search, but homing procedures can be used on any radio frequency to which *both* a transmitter and DF receiver can be tuned.

a. L-Tronics DF Unit. First you have to determine the direction to the ELT. When you fly directly toward a signal, the left/right DF needle remains centered. However, when you head directly *away* from the signal, the needle also centers. A simple, quick maneuver is used to determine if you are going toward or away from the signal. Starting with the left/right needle centered, the pilot turns the aircraft in either direction so that the needle moves away from center. If he turns left, and the needle deflects to the right, the ELT is in front. If the pilot turns back to the right to center the needle, and then maintains the needle in the center, you will eventually fly to the ELT. If, in the verification turn, the pilot turns left and the needle swings to the extreme left, then the ELT is behind you. Continue the left turn until the needle returns to the center. You are now heading toward the ELT, and as long as the pilot maintains the needle in the center, you will fly to the ELT.

Flying toward the ELT, maintaining the needle in the center of the indicator *is* the actual homing process. If the needle starts to drift left of center, steer slightly left to bring the needle back to the center. If it starts to drift right, turn slightly back to the right. Once you have completed the direction-verification turn, you will not need large steering corrections to keep the needle in the center.

When passing over the ELT or transmission source, the left/right needle will indicate a *strong* crossover pattern. The needle will make a distinct left-to-right or right-to-left movement and then return to the center. This crossover movement is *not* a mere fluctuation; the needle swings fully, from one side of the indicator to the other and then returns to the center.

During homing you may encounter situations where the needle *suddenly* drifts to one side then returns to center. If the heading has been steady, and the needle previously centered, such a fluctuation may have been caused by a signal from a second transmitter. Another aircraft nearby can also cause momentary needle fluctuations that you might not hear, but the needle in the DF will react to it. Signal reflections from objects or high terrain can also cause needle fluctuations at low altitudes in mountainous terrain or near metropolitan areas.

b. Becker SAR-DF 517. Just like when using the L-Tronics DF, you will need to determine the bearing to the target. With the Becker DF, you will essentially follow the directions on pages of the display.



Page 1: 360° bearing

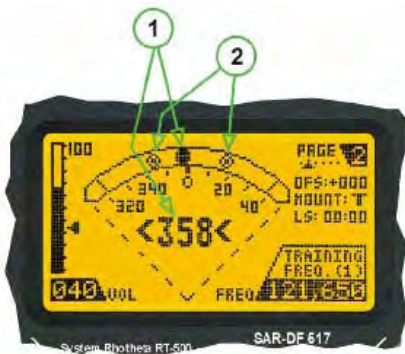

Page 2: expanded ±45°



Page 3: bearing text

1) Relative Bearing value. It is very important to realize that this is a relative bearing that is relative to the nose of the aircraft, NOT the heading to be flown.

2) Spread Maximum deviation of un-averaged bearing. Good bearing results even with a spread of 45° as a result of the averaging procedure. Note: as you approach near the ELT and the signal becomes very strong, the spread will narrow.

3) Receive level Field strength. Page 1 shows approximately 50%, Page 2 shows approx. 75%

4) Squelch level Squelch level must be above the noise level without a received signal.

5) Offset Corrects for antenna alignment (adjusted in the edit-menu).

6) Mounting Page 1 shows a BOTTOM mounted antenna. Page 3 shows TOP mounted.

7) LS: ---:--- Internal timer (LS meaning last signal) indicating the time since the last signal was received, displayed in min /sec

How do I read the above displays?

- Page 1 indicates that the target is 2 degrees to the right, so the observer would tell the pilot to turn 2 degrees right to center the ball at the top of the display.
- Page 2 indicates that the target is 2 degrees to the left, so the observer tells the pilot to turn two degrees to the left to center the ball at the top of the display.
- Page 3 indicates that the target is 6 degrees to the right, so the observer tells the pilot to turn 6 degrees to right (there is no ball displayed on this page).

How do you know when you are over the target?

- The “ball” will swing to the 180 degree position on PAGE 1 just after you pass over the target.

- When you are exactly over the target you may notice a “cone of influence” similar to passing over a VOR during which the signal may be lost momentarily before it swings to 180 degrees.

3. *Wing null*. The wing null (or wing shadow) method is based on the assumption that the metal skin of the search aircraft’s wing and fuselage will block incoming ELT signals from the receiving antenna during steep-banked turns.

Due to the length of the description of this search method and the number of figures, refer to the "Wing Shadow method (wing null)" section of the Mission Aircrew Reference Text (MART) for details.

4. The *aural* (or hearing) search technique is based on an assumption that an ELT's area of apparent equal signal strength is circular.

Please refer to the "Aural (or hearing) search" section of the MART for details.

5. To employ the *metered* search method, the observer uses a signal strength meter to monitor the ELT signal. Once the aircraft enters the search area, the observer plots two positions of equal meter strength.

Please refer to the "Metered search" section of the MART for details.

6. Signal reflection and interference. Radio signals reflect off terrain and manmade objects, and this can be a problem for search and rescue teams. In an electronic search, it is vitally important to know if the equipment is reacting to reflected signals and what you can do to overcome the problem.

Please refer to the "Signal Reflection and Interference" section of the MART.

Additional Information

Using the DF is covered in Task O-2005 (Operate the Aircraft DF), and may be performed concurrently with this task. More detailed information and figures on this topic are available in Chapter 10 and Attachment 2 of the MART and the user’s manual for the Becker SAR-DF 517..

Practice

Setup: The student needs access to an aircraft with an operable DF, a sectional and or a map of the practice area. Place a practice beacon in a suitable location for each type (method) of DF search. [Note: If you normally operate in or near congested airspace, you should conduct some of these practice sorties under ATC control inside the congested airspace.]

The mission pilot should let the observer perform as much of the search duties as is practical. Where possible, have the student direct the pilot (particularly for headings) by interpreting DF signals.

As a minimum, the student should practice the homing and wing null search methods. Demonstration of the aural and metered search methods is desirable, but they may be simulated. [Note: It is highly desirable to have a ground crew available during practice. The observer can then lead the ground crew to the area where the practice beacon is located and let the ground crew find the beacon.]

The student should start out searching for a practice beacon located in an open area where the signal will not be reflected. At first, the practice beacon's location should be clearly marked (e.g., using an adjacent signal panel or wreckage simulations) so the student can see the results of his efforts.

After the student has successfully demonstrated basic proficiency, place the practice beacon in an open area but do not mark its location. Have the student locate the beacon and tell you its approximate location. This

provides a good simulation of a night search. After the student has demonstrated proficiency, practice at least one DF (using the homing and wing null methods) at night.

After the student has mastered the basic ELT search methods, place a practice beacon in locations where the signal is weakened or reflected (e.g., inside a hanger, along a metal fence, or near a power transmission line).

Evaluation Preparation

Setup: Provide the student with an aircraft and pilot, a sectional and/or map of the local area. Place a practice beacon in a suitable location for each type of ELT search.

Brief Student: You are a Mission Observer trainee asked to perform ELT searches.

Evaluation

<u>Performance measures</u>	<u>Results</u>	
1. Locate a practice beacon using the following search methods:		
a. Homing to a non-reflected signal.	P	F
b. Homing to a non-reflected signal at night (combine with 1.d, if possible).	P	F
c. Homing to a reflected signal.	P	F
d. Wing null to a non-reflected signal (one during the day and one at night).	P	F
2. Locate a practice beacon using the following search methods (may be simulated):		
a. Aural.	P	F
b. Signal.	P	F
3. Discuss night and IFR searches, with particular emphasis on the hazards and precautions.	P	F
4. Discuss signal reflection and interference.	P	F

Student must receive a pass on all performance measures to qualify in this task. If the individual fails any measure, show what was done wrong and how to do it correctly.

ASSIST IN PLANNING AND PERFORMING A ROUTE SEARCH

CONDITIONS

You are a Mission Observer trainee and must assist a Mission Pilot in planning and performing a route search.

OBJECTIVES

Assist a Mission Pilot in planning and performing a route search.

TRAINING AND EVALUATION

Training Outline

1. As a Mission Observer trainee, the ability to assist the Mission Pilot in planning and performing a route search pattern is essential. The observer learns to plan the search pattern in order to better assist the mission pilot and to more effectively direct scanners.
2. General. Because of the accuracy and reliability of the present Global Positioning System and GPS receivers, CAP aircrews are now able to navigate and fly search patterns with unprecedented effectiveness and ease. The GPS has become the primary instrument for CAP air missions, and it is vital that observers know how to setup and use the GPS. However, observers must also be familiar with the other navigational instruments onboard CAP aircraft: these instruments complement the GPS and serve as backups in case of GPS receiver problems.

The observer (as mission commander) must be aware of how many scanners will be on board in order to assign which side of the aircraft they should scan. *Planning and executing a search pattern with only one scanner on board is quite different from one where you have two scanners.* Likewise, having an observer and two scanners on board will allow the observer to spend more time assisting the pilot without seriously decreasing search effectiveness.

When you are planning and flying search patterns, always perform a *stupid check* -- as in "Hey! Wait a minute. This is stupid." Use this to see if your headings, waypoint positions, lat/long coordinates and distances look sensible. At a minimum, perform this check after you finish planning, when you start your pattern, and periodically thereafter. For example, you've just entered a set of lat/long coordinates into the GPS and turned to the heading shown on the GPS. You know the coordinates represent a lake southwest of your position, so check the heading indicator to see you're actually traveling in a southwesterly direction. Or, you know the lake is approximately 25 miles away; check the distance indicated on the GPS! You'd be surprised how many mistakes this method will catch.

Pre-planning (plotting) your search pattern results in the most effective search. Pre-planning sets the details of the sortie in your mind and makes entering your data (correctly) into the GPS much easier. This allows the pilot and observer to concentrate on their primary task by minimizing navaid setup time and reducing confusion. Worksheets can be used (see the *Flight Guide*, MART Attachment 2) to pre-plan your search patterns, but they are just one method.

3. Route search pattern. The route (track line) search pattern is normally used when an aircraft has disappeared without a trace. This search pattern is based on the assumption that the missing aircraft has crashed or made a forced landing on or near its intended track (route). It is assumed that detection may be aided by survivor signals or by electronic means. The track line pattern is also used for night searches (in suitable

weather). A search aircraft using the track line pattern flies a rapid and reasonably thorough coverage on either side of the missing aircraft's intended track.

4. Search altitude for the track line pattern usually ranges from 1000 feet above ground level (AGL) to 2000 feet AGL for day searches, while night searches range 2000 to 3000 feet AGL (either depending upon light conditions and visibility). Lat/long coordinates for turns are determined and then entered into the GPS as waypoints, which may then be compiled into a flight plan.

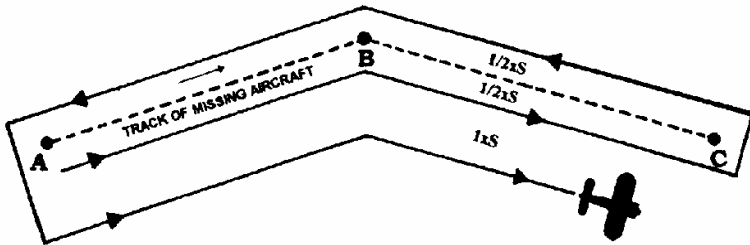

The search crew begins by flying parallel to the missing aircraft's intended course line, using the track spacing (labeled "S") determined by the incident commander or planning section chief. On the first pass, recommended spacing may be one-half that to be flown on successive passes. Flying one-half "S" track spacing in the area where the search objective is most likely to be found can increase search coverage.

5. You may use a worksheet to draw the route and to log coordinates and distinctive features. As a backup, note applicable VOR radials and cross-radials. The GX55 has a function called "parallel track offset" that is very handy for route searches. This function allows you to create a parallel course that is offset to the left or right (up to 20 nm) of your current flight plan. This function can also be useful on when you wish to search a 'corridor' of airspace.

Additional Information

Search patterns are covered in tasks O-2109 thru O-2115 and may be combined in any fashion. More detailed information and figures on this topic are available in Chapter 11 of the MART.

Practice

Setup: Give the student a route search to plan and perform. The student should have a sectional chart, plotter, and worksheets as needed. A qualified Mission Pilot should be available to assist the trainee.

A search target should be positioned in the search area, if possible.

Brief the pilot. The pilot should fly the route over a sufficient length (out and back) to allow the student time to demonstrate proficiency in all aspects of the search. Search altitude, airspeed and track spacing should be selected to match terrain and conditions: 1,000' to 2,000' AGL, 100 knots, and one mile track spacing is recommended.

Depending on the level of proficiency of the student, one or more of these tasks may be practiced simultaneously:

Planning. All mission sorties must be thoroughly planned: this ensures the pilot and crew can accomplish the sortie objectives safely and precisely. Treat each sortie as if it were an actual mission. Each time the student practices a sortie all required paperwork should be completed as part of the drill. The student should sign herself into the mission, ensure that the pilot signs in the aircraft, receive her assignment from you (the briefing

officer), plan the sortie, and assist the pilot in completing the flight plan and preliminary mission data portions of the CAPF 104.

The pilot should review the weight and balance, fuel assumptions, and information entered onto the CAPF 104 with the student.

Preflight and pilot briefings. Ensure the student receives pilot safety and mission briefings from the pilot. The student will perform safety assignments as directed (e.g., collision avoidance during taxi and in flight).

Equipment. To the extent possible, the student should operate the communications and navigation equipment. The student should set up and enter information into the equipment (especially the GPS) prior to taxi. [Where necessary for training, the trainer should assist the student in setting up navigation equipment (particularly the GPS) in flight.]

Initial training. Depending on the proficiency and skills of the student, the trainer may need to demonstrate all aspects of a route search. This gives the student time to absorb the information and work on such skills as setting up, entering data, and using the navigational equipment.

For each practice sortie, watch for:

- 1) Proper setup and use of the navigational equipment, particularly the GPS. Ensure that the student does not change any navigational or communications equipment setting without the knowledge of the PIC.
- 2) Proper ATC and CAP FM communications technique and terminology. Initially, have the student tell the pilot and/or trainer what she intends to say *before* she transmits.
- 3) Proper and attentive collision avoidance practices during the critical phases of flight.
- 4) Safety. The student should spend most of her time looking outside the aircraft (see and avoid) when enroute to the search area, and most of her time acting as a scanner while in the search area. Initially, the student will spend too much time with her eyes inside the aircraft (e.g., manipulating the GPS) until she is comfortable and proficient with the equipment. Get the student into the habit of *not looking inside the aircraft for more than five seconds at a time* to manipulate communications and navigational equipment.
- 5) Accurate situational awareness at all times.

Evaluation Preparation

Setup: Give the student a route search to plan and perform. The student should have a sectional chart, plotter, and worksheets as needed. A qualified Mission Pilot should be available to assist the trainee during the planning and flying stages.

A search target should be positioned in the search area, if possible.

Brief the pilot. The pilot should fly the pattern long enough to allow the student time to demonstrate proficiency in all aspects of the search. Search altitude, airspeed and track spacing should be selected to match terrain and conditions: 1,000' to 2,000' AGL, 100 knots, and one mile track spacing is recommended.

Run the sortie as it would be during an actual mission. Have the student sign in, sign in the aircraft, and complete all required paperwork. Brief the sortie as if you were the Briefing Officer during a mission.

Brief Student: You are a Mission Observer trainee asked to assist a Mission Pilot in planning and performing a route search.

Evaluation

<u>Performance measures</u>	<u>Results</u>	
1. Sign into the mission.	P	F
2. Receive a sortie briefing, asking questions as necessary.	P	F
3. Assist in planning a route search from Point A to B and back. Include:		
a. Position coordinates for the route (lat/long and VOR radials/cross-radials).	P	F
b. Altitude restrictions, obstacles and other hazards (e.g., MTRs and SUAs).	P	F
c. Scanner assignments (discuss as necessary).	P	F
4. Assist in filling out the flight plan and preliminary mission data on the CAPF 104.	P	F
5. Receive pilot safety and mission briefings, asking questions as necessary.	P	F
6. Demonstrate and discuss safety during each critical phase of the flight. In particular, demonstrate collision avoidance and enforce sterile cockpit rules.	P	F
7. Demonstrate proper ATC communications, as applicable.	P	F
8. Setup the CAP FM radio and perform all required radio reports (may be simulated).	P	F
9. Assist in a route search. Demonstrate:		
a. Proper use of nav aids (GPS as primary; VOR as backup).	P	F
b. Proper use of radios (ATC as required, and CAP FM radio reports).	P	F
c. Proper scanner assignment (may be simulated).	P	F
d. Ability to spot the search target (if applicable).	P	F
10. Ensure the aircraft is secured at the end of the sortie (ready for next sortie).	P	F
11. Assist in filling out the remainder of the CAPF 104 and debrief the sortie.	P	F

Student must receive a pass on all performance measures to qualify in this task. If the individual fails any measure, show what was done wrong and how to do it correctly.

O-2110
ASSIST IN PLANNING AND PERFORMING A PARALLEL TRACK SEARCH

CONDITIONS

You are a Mission Observer trainee and must assist a Mission Pilot in planning and performing a parallel track search.

OBJECTIVES

Assist a Mission Pilot in planning and performing a parallel track search.

TRAINING AND EVALUATION

Training Outline

1. As a Mission Observer trainee, the ability to assist the Mission Pilot in planning and performing a parallel track search pattern is essential. The observer learns to plan the search pattern in order to better assist the mission pilot and to more effectively direct scanners.
2. Parallel track search pattern. The parallel track (sweep) search pattern is normally used when one or more of the following conditions exist: a) the search area is large and fairly level, b) only the approximate location of the target is known, or c) uniform coverage is desired. This type of search is used to search a grid.
3. The aircraft proceeds to a corner of the search area and flies at the assigned altitude, sweeping the area maintaining parallel tracks. The first track is at a distance equal to one-half ($1/2$) track spacing (S) from the side of the area.

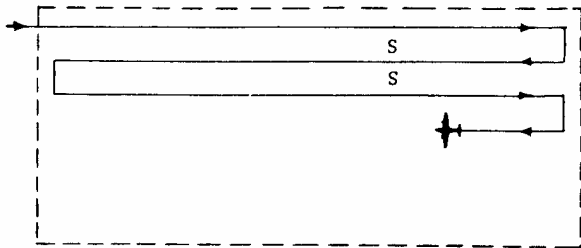

4. You may use a worksheet to draw the route and to log coordinates and distinctive features. As a backup, note applicable VOR radials and cross-radials. You can use this to enter the latitudes and longitudes that define the entry point and bound the grid, or to generate a flight plan.

Grid Coordinates

SECTIONAL: STL (2)S GRID # 104 A B C (D)
 ENTRY POINT: N 39°07.5' W 86°00'
 EXIT POINT: N 39°07.5' W 86°07'

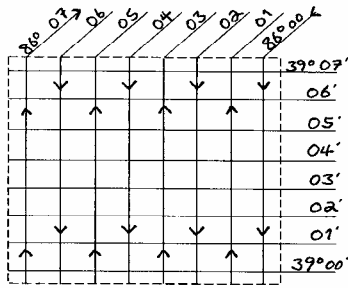

IDENTIFIER	NAVIGATIONAL AIDS	
	FREQUENCY	RADIAL
1. <u>OOM</u>	<u>110.2</u>	<u>090°</u>
2. <u>AB3</u>	<u>112.4</u>	<u>330°</u>

5. In the worksheet example, you will be searching STL Grid #104-D, which is a quarter-grid measuring 7.5' x 7.5'. Plot the grid's coordinates and draw the pattern starting at the entry point (northeast corner); include track spacing (one nm) and the direction of the legs (north/south). You will enter the entry point coordinates as a waypoint (N 39° 07' W 86° 00'; northeast corner). As you fly to the entry point, the pilot should set up at search altitude and speed about 3-5 miles out (this ensures a stabilized entry so that you can begin searching immediately).

Also, always enter relevant VOR cross-radials onto your worksheet and use them as a backup and to verify important positions.

6. All the data you need set up this search pattern in the GX55 is on the worksheet:

- Type of Grid and Sectional (US grid, STL).
- Type of pattern (Parallel Line).
- Grid 104D2, where '2' indicates entering the northeast corner of D quadrant. *
- Spacing (1 nm).
- Direction of Travel (N/S).

* The GX-55 identifies the corners of quadrants by numbers: 1 = enter the NW corner; 2 = NE corner; 3 = SE corner; and 4 = SW corner. In our example you would enter "104D2."

Note: If you wish, record this data separately (e.g., a list or table) to make it even easier to enter into the GX-55. The example, above, has the data listed in the sequence that you enter into the GX-55.

Additional Information

Search patterns are covered in tasks O-2109 thru O-2115 and may be combined in any fashion. More detailed information and figures on this topic are available in Chapter 11 of the MART.

Practice

Setup: Give the student a parallel (one-quarter grid) search to plan and perform. The student should have a sectional chart, plotter, and worksheets as needed. A qualified Mission Pilot should be available to assist the trainee.

Brief the pilot. The pilot should fly the pattern long enough to allow the student time to demonstrate proficiency in all aspects of the search. Search altitude, airspeed and track spacing should be selected to match terrain and conditions: 1,000' to 2,000' AGL, 90 knots, and one mile track spacing is recommended.

Depending on the level of proficiency of the student, one or more of these tasks may be practiced simultaneously:

Planning. All mission sorties must be thoroughly planned: this ensures the pilot and crew can accomplish the sortie objectives safely and precisely. Treat each sortie as if it were an actual mission. Each time the student practices a sortie all required paperwork should be completed as part of the drill. The student should sign herself into the mission, ensure that the pilot signs in the aircraft, receive her assignment from you (the briefing officer), plan the sortie, and assist the pilot in completing the flight plan and preliminary mission data portions of the CAPF 104.

The pilot should review the weight and balance, fuel assumptions, and information entered onto the CAPF 104 with the student.

Preflight and pilot briefings. Ensure the student receives pilot safety and mission briefings from the pilot. The student will perform safety assignments as directed (e.g., collision avoidance during taxi and in flight).

Equipment. To the extent possible, the student should operate the communications and navigation equipment. The student should set up and enter information into the equipment (especially the GPS) prior to taxi. [Where necessary for training, the trainer should assist the student in setting up navigation equipment (particularly the GPS) in flight.]

Initial training. Depending on the proficiency and skills of the student, the trainer may need to demonstrate all aspects of a parallel track (grid) search. This gives the student time to absorb the information and work on such skills as setting up, entering data, and using the navigational equipment.

For each practice sortie, watch for:

- 1) Proper setup and use of the navigational equipment, particularly the GPS. Ensure that the student does not change any navigational or communications equipment setting without the knowledge of the PIC.
- 2) Proper ATC and CAP FM communications technique and terminology. Initially, have the student tell the pilot and/or trainer what she intends to say *before* she transmits.
- 3) Proper and attentive collision avoidance practices during the critical phases of flight.
- 4) Safety. The student should spend most of her time looking outside the aircraft (see and avoid) when enroute to the search area, and most of her time acting as a scanner while in the search area. Initially, the student will spend too much time with her eyes inside the aircraft (e.g., manipulating the GPS) until she is comfortable and proficient with the equipment. Get the student into the habit of *not looking inside the aircraft for more than five seconds at a time* to manipulate communications and navigational equipment.
- 5) Accurate situational awareness at all times.

Evaluation Preparation

Setup: Give the student a parallel track (one-quarter-grid) search to plan and perform. The student should have a sectional chart, plotter, and worksheets as needed. Brief the pilot on the task, if necessary. A qualified Mission Pilot should be available to assist the trainee during the planning and flying stages.

A search target should be positioned in the search area, if possible.

The pilot will enter and fly the grid long enough to allow the student to demonstrate proficiency in all aspects of the search. Search altitude, airspeed and track spacing should be selected to match terrain and conditions: 1,000' AGL, 90 knots, and one mile track spacing is recommended.

Run the sortie as it would be during an actual mission. Have the student sign in, sign in the aircraft, and complete all required paperwork. Brief the sortie as if you were the Briefing Officer during a mission.

Brief Student: You are a Mission Observer trainee asked to assist a Mission Pilot in planning and performing a parallel track (one-quarter grid) search.

Evaluation

<u>Performance measures</u>	<u>Results</u>
1. Sign into the mission.	P F
2. Receive a sortie briefing, asking questions as necessary.	P F
3. Assist in planning a one-quarter grid search. Include:	
a. Estimated time enroute, time in the search area, and fuel requirements.	P F
b. Position coordinates for the entry and exit points (lat/long & VOR radials/cross-radials).	P F
c. Position coordinates for the legs (lat/long and VOR radials/cross-radials).	P F
d. Altitude restrictions, obstacles and other hazards (e.g., MTRs and SUAs).	P F
e. Discuss observer/scanner assignments for all possible combinations.	P F
4. Assist in filling out the flight plan and preliminary mission data on the CAPF 104.	P F
5. Receive pilot safety and mission briefings, asking questions as necessary.	P F
6. Demonstrate and discuss safety during each critical phase of the flight. In particular, demonstrate collision avoidance and enforce sterile cockpit rules.	P F
7. Demonstrate proper ATC communications.	P F
8. Setup the CAP FM radio and perform all required radio reports (may be simulated).	P F
9. Perform the grid search. Demonstrate:	
a. Proper use of nav aids (GPS as primary; VOR as backup).	P F
b. Proper use of radios (ATC as required, and CAP FM radio reports).	P F
c. Proper scanner assignment (may be simulated).	P F
d. Ability to spot the search target (if applicable).	P F
10. Demonstrate proper attention to fuel management.	P F
11. Ensure the aircraft is secured at the end of the sortie (ready for next sortie).	P F
12. Assist in filling out the remainder of the CAPF 104 and debrief the sortie.	P F

Student must receive a pass on all performance measures to qualify in this task. If the individual fails any measure, show what was done wrong and how to do it correctly.

ASSIST IN PLANNING AND PERFORMING A POINT-BASED SEARCH**CONDITIONS**

You are a Mission Observer trainee and must assist a Mission Pilot in planning and performing a point-based search.

OBJECTIVES

Assist a Mission Pilot in planning and performing a point-based search (expanding square or sector).

TRAINING AND EVALUATION**Training Outline**

1. As a Mission Observer trainee, the ability to assist the Mission Pilot in planning and performing a point-based search pattern is essential. The observer learns to plan the search pattern in order to better assist the mission pilot and to more effectively direct scanners.

Point-based searches are organized around a point on the ground. These patterns are used when the approximate location of the target is known and are not intended to cover large areas. Examples are the expanding square, sector and circle search patterns.

2. Expanding Square search pattern. The expanding square search pattern is used when the search area is small (normally, areas less than 20 miles square), and the position of the survivors is known within close limits. This pattern begins at an initially reported position and expands outward in concentric squares. If error is expected in locating the reported position, or if the target were moving, the square pattern may be modified to an expanding rectangle with the longer legs running in the direction of the target's reported, or probable, movement.

If the results of the first square search of an area are negative, the search unit can use the same pattern to cover the area more thoroughly. The second search of the area should begin at the same point as the first search; however, the first leg of the second search is flown diagonally to the first leg of the first search. Consequently, the entire second search diagonally overlays the first one. The bold, unbroken line in the figure illustrates the first search, while the dashed line represents the second search. Track spacing indicated in the figure is "cumulative," showing the total width of the search pattern at a given point on that leg. Actual distance on a given leg from the preceding leg on the same side of the pattern is still only one "S," the value determined by the incident commander or planning section chief.

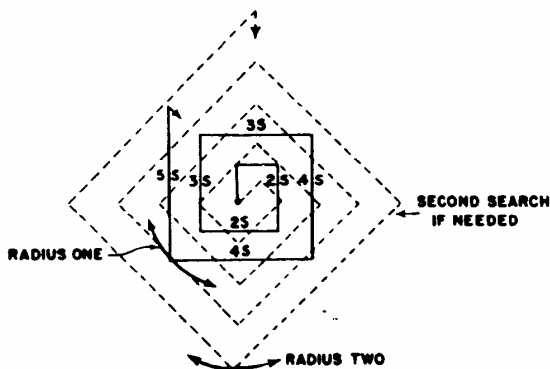

- The GPS is used because this pattern requires precise navigation and is affected by wind drift. Even using the GPS, it is helpful for the pilot to orient the expanding square pattern along the cardinal headings to reduce confusion during turns. [Or, you can enter the pattern as a flight plan and it will direct your turns.]
- You may use a worksheet to draw the pattern and to log coordinates and distinctive features. As a backup, note applicable VOR radials and cross-radials.

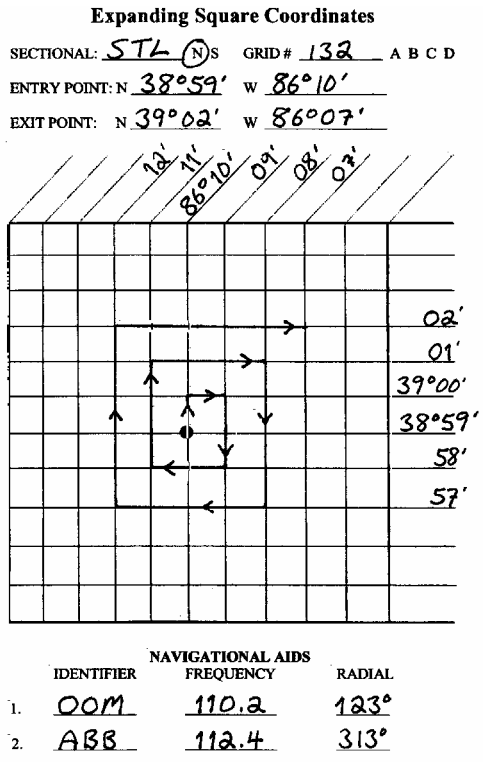

5. Fill the worksheet with the lat/longs that describe the expanding square. Starting at the entry point (e.g., a 483' AGL tower), draw the square by going one mile north, then one mile east, then two miles south, and so on. You set it up this way because it is best to fly the square by first flying due north and then making all subsequent turns to the right; right turns are used because they allow the observer and scanner(s) to see the ground during the turns. You use cardinal headings because they are easiest for the pilot to fly. Length and width of the pattern may be modified to suit the requirements and conditions of the individual search.

Enter the lat/long of the starting point (N 38° 59' W 86° 10') into the GPS and save it as a waypoint. As you fly to the entry point, the pilot should set up at search altitude and speed about 3-5 miles out (this ensures a stabilized entry so that you can begin searching immediately). The pilot should fly the pattern using the heading indicator and continuously displayed latitude and longitude on the GPS.

Note: If the aircraft doesn't have an operable GPS the first leg should be flown directly into or directly with the wind. Every other leg will thus be affected by the wind in a relatively consistent manner.

6. In the GX55, the expanding square will radiate from a starting waypoint according to the spacing between lines and at an angle selected by you. All the data you need set up this search pattern in the GX55 is on the worksheet:

- Type of Grid and Sectional (US grid, STL).
- Type of pattern (Expanding Square).
- Starting Waypoint (483' AGL tower, N 38° 59' W 86° 10').

- Spacing (1 nm).
- Direction of Travel (due north, 000°).

* 9.9 nm is the longest leg length you can select on the GX-55.

7. Sector search pattern. A sector search pattern is also best planned on the ground, as it involves multiple headings and precise leg lengths. The pilot will fly over the suspected location and out far enough to make a turn, fly a leg that is equal to the maximum track spacing, and then turn back to fly over the point again. This continues until the point has been crossed from all the angles.

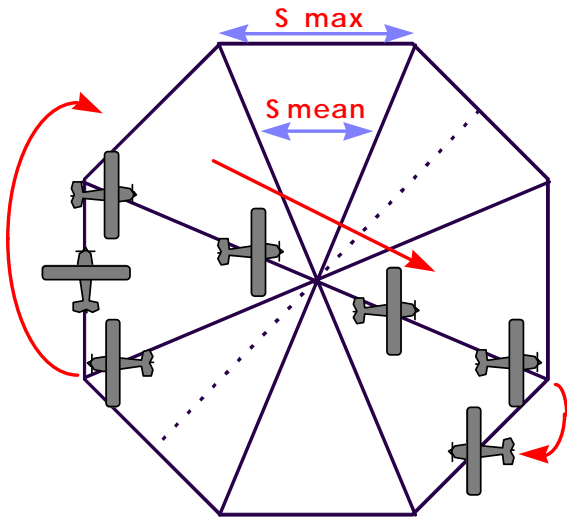

This search pattern provides concentrated coverage near the center of the search area and provides the opportunity to view the suspected area from many angles (this minimizes terrain and lighting problems).

8. Circle search pattern. A circle search pattern may be used when you have a prominent ground reference. The pilot executes a series of 'turns around a point' (circles of uniform distance from a ground reference point). Once the first circle is flown, the pilot moves outward by the desired track spacing and repeats the maneuver. This pattern is usually only used to cover a very small area, which is dependent upon search visibility (the pilot must be able to see the ground reference). Its benefit is that you only need to be able to locate and see the ground reference point, and no prior planning is needed. However, the pilot must constantly correct for the wind.

Additional Information

Search patterns are covered in tasks O-2109 thru O-2115 and may be combined in any fashion. More detailed information and figures on this topic are available in Chapter 11 of the MART.

Practice

Setup: Give the student an expanding square or sector search to plan and perform. The student should have a sectional chart, plotter, and worksheets as needed. A qualified Mission Pilot should be available to assist the trainee.

Brief the pilot. The pilot should fly the pattern long enough to allow the student time to demonstrate proficiency in all aspects of the search. Search altitude, airspeed and track spacing should be selected to match terrain and conditions: 1,000' to 2,000' AGL, 90 knots, and one mile track spacing is recommended.

Depending on the level of proficiency of the student, one or more of these tasks may be practiced simultaneously:

Planning. All mission sorties must be thoroughly planned: this ensures the pilot and crew can accomplish the sortie objectives safely and precisely. Treat each sortie as if it were an actual mission. Each time the student practices a sortie all required paperwork should be completed as part of the drill. The student should sign herself into the mission, ensure that the pilot signs in the aircraft, receive her assignment from you (the briefing officer), plan the sortie, and assist the pilot in completing the flight plan and preliminary mission data portions of the CAPF 104.

The pilot should review the weight and balance, fuel assumptions, and information entered onto the CAPF 104 with the student.

Preflight and pilot briefings. Ensure the student receives pilot safety and mission briefings from the pilot. The student will perform safety assignments as directed (e.g., collision avoidance during taxi and in flight).

Equipment. To the extent possible, the student should operate the communications and navigation equipment. The student should set up and enter information into the equipment (especially the GPS) prior to taxi. [Where necessary for training, the trainer should assist the student in setting up navigation equipment (particularly the GPS) in flight.]

Initial training. Depending on the proficiency and skills of the student, the trainer may need to demonstrate all aspects of a point-based search. This gives the student time to absorb the information and work on such skills as setting up, entering data, and using the navigational equipment.

For each practice sortie, watch for:

- 1) Proper setup and use of the navigational equipment, particularly the GPS. Ensure that the student does not change any navigational or communications equipment setting without the knowledge of the PIC.
- 2) Proper ATC and CAP FM communications technique and terminology. Initially, have the student tell the pilot and/or trainer what she intends to say *before* she transmits.
- 3) Proper and attentive collision avoidance practices during the critical phases of flight.
- 4) Safety. The student should spend most of her time looking outside the aircraft (see and avoid) when enroute to the search area, and most of her time acting as a scanner while in the search area. Initially, the student will spend too much time with her eyes inside the aircraft (e.g., manipulating the GPS) until she is comfortable and proficient with the equipment. Get the student into the habit of *not looking inside the aircraft for more than five seconds at a time* to manipulate communications and navigational equipment.
- 5) Accurate situational awareness at all times.

Evaluation Preparation

Setup: Give the student an expanding square or sector search to plan and perform. The student should have a sectional chart, plotter, and worksheets as needed. A qualified Mission Pilot should be available to assist the trainee during the planning and flying stages.

A search target should be positioned in the search area, if possible.

The pilot will enter and fly the pattern long enough to allow the student to demonstrate proficiency in all aspects of the search. Search altitude, airspeed and track spacing should be selected to match terrain and conditions: 1,000' AGL, 90 knots, three mile legs, and one mile track spacing is recommended.

Run the sortie as it would be during an actual mission. Have the student sign in, sign in the aircraft, and complete all required paperwork. Brief the sortie as if you were the Briefing Officer during a mission.

Brief Student: You are a Mission Observer trainee asked to assist a Mission Pilot in planning and performing a point-based search.

Evaluation

<u>Performance measures</u>	<u>Results</u>
1. Sign into the mission.	P F
2. Receive a sortie briefing, asking questions as necessary.	P F
3. Assist in planning a point-based search (expanding square or sector). Include:	
a. Estimated time enroute, time in the search area, and fuel requirements.	
b. Position coordinates for the entry and exit points (lat/long & VOR radials/cross-radials).	P F
c. Position coordinates for the legs (lat/long and VOR radials/cross-radials).	P F
d. Altitude restrictions, obstacles and other hazards (e.g., MTRs and SUAs).	P F
e. Discuss observer/scanner assignments for all possible combinations.	P F
4. Assist in filling out the flight plan and preliminary mission data on the CAPF 104.	P F
5. Receive pilot safety and mission briefings, asking questions as necessary.	P F
6. Demonstrate and discuss safety during each critical phase of the flight. In particular, demonstrate collision avoidance and enforce sterile cockpit rules.	P F
7. Demonstrate proper ATC communications.	P F
8. Setup the CAP FM radio and perform all required radio reports (may be simulated).	P F
9. Perform the point-based search (expanding square or sector). Demonstrate:	
a. Proper use of nav aids (GPS as primary; VOR as backup).	P F
b. Proper use of radios (ATC as required, and CAP FM radio reports).	P F
c. Proper scanner assignment (may be simulated).	P F
d. Ability to spot the search target (if applicable).	P F
10. Demonstrate proper attention to fuel management.	P F
11. Ensure the aircraft is secured at the end of the sortie (ready for next sortie).	P F
12. Assist in filling out the remainder of the CAPF 104 and debrief the sortie.	P F

Student must receive a pass on all performance measures to qualify in this task. If the individual fails any measure, show what was done wrong and how to do it correctly.

ASSIST IN PLANNING AND PERFORMING A CREEPING LINE SEARCH

CONDITIONS

You are a Mission Observer trainee and must assist a Mission Pilot in planning and performing a creeping line search.

OBJECTIVES

Assist a Mission Pilot in planning and performing a creeping line search.

TRAINING AND EVALUATION

Training Outline

1. As a Mission Observer trainee, the ability to assist the Mission Pilot in planning and performing a creeping line search pattern is essential. The observer learns to plan the search pattern in order to better assist the mission pilot and to more effectively direct scanners.
2. Creeping line search pattern. The creeping line search pattern is similar to the parallel patterns. The parallel pattern search legs are aligned with the major, or longer, axis of the rectangular search areas, whereas the search legs of the creeping line pattern are aligned with the minor or shorter axis of rectangular search areas. The creeping line pattern is used when: a) the search area is narrow, long, and fairly level, b) the probable location of the target is thought to be on either side of the search track within two points, or c) there is a need for immediate coverage of one end of the search area.
3. The creeping line is a succession of search legs along a line. The starting point is located one-half search track spacing inside the corner of the search area.

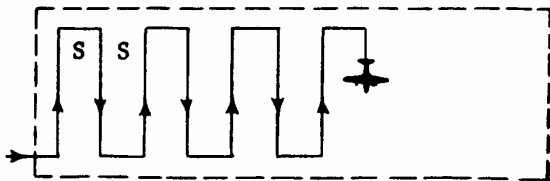

4. You may use a worksheet to draw the pattern and to log coordinates and distinctive features. As a backup, note applicable VOR radials and cross-radials. [Note: You may also create a flight plan for the pattern.]

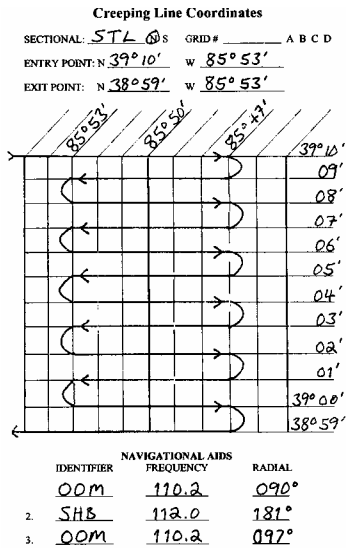

5. In the worksheet example (above), assume you will be searching along a highway between two towns. Draw the pattern starting at the entry point; include track spacing (one nm) and make each leg extend three nm east and west of the highway. You will enter the entry point coordinates as a waypoint (N 39° 10' W 85° 53'). As you fly to the entry point, the pilot should set up at search altitude and speed about 3-5 miles out (this ensures a stabilized entry so that you can begin searching immediately). The pilot should fly the pattern using the GPS' continuous lat/long display. In this example, the pilot will initially fly a constant latitude line of N 39° 10' until you reach W 85° 47' where she will turn right 180° and stabilize on a constant latitude line of N 39° 09'; repeat this process until the search is completed.

If the route is along a cardinal heading such as the highway example above, then the pilot will simply fly the creeping line using continuously displayed latitude and longitude. However, when the route is not a straight line aligned with a cardinal heading, another method may be used.

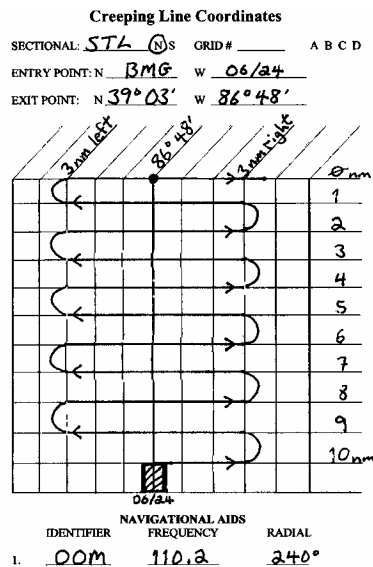

Assume that the aircraft will be flying a creeping line for ten miles southwest along an (imaginary) extended runway centerline (06/24 at BMG), and it is desired to fly three miles to either side of the extended runway centerline with one-mile track spacing. Draw the pattern starting at the entry point (Runway 06, BMG); include track spacing (one nm) and make each leg extend three miles either side of the extended centerline. In the right column enter the distance from the waypoint for each leg, starting at ten miles and counting down. Enter the

exit point's lat/long (N 39° 03' W 86° 48'; ten miles southwest of the end of runway 06) in the GPS as a waypoint.

Enter the airport (BMG) as a destination and the pilot will fly to it. Select the waypoint you created as your new destination.

When the pilot flies over the end of Runway 06, zero (reset) the CDI display on the GPS. This sets up a *route* in the GPS that represents a direct line between the entry (end of runway 06) and exit points. The GPS should show ten miles to the destination, and the CDI will be centered.

The pilot will use the distance to the destination to establish and maintain one-mile track spacing; she will monitor the CDI deviation indication to indicate when you have gone three miles to either side of the line.

The pilot begins his first turn, for example to the right. By maintaining the distance from the destination constant (e.g., ten miles) the aircraft will be flying *almost* perpendicular to the extended runway centerline. Watch the CDI, which will begin showing that the aircraft is deviating from the intended route to the right. When the aircraft has deviated by almost three miles (the length of your right leg) the pilot will begin a turn to the left. The turn will be completed so that the aircraft will now be flying in the opposite direction at a distance of nine miles from the destination (the one-mile track spacing).

Now watch the CDI begin to return to center while maintaining a constant nine-mile distance from the destination. The pilot will continue as the CDI begins to deviate to the left, and the next turn (to the right) will begin as you approach a three-mile deviation. Continue this pattern until you have completed your search.

Note: By using this technique you will actually be flying arcs instead of the usual squared (rectangular) legs. This is of little concern since the purpose is to cover the entire search area in a methodical manner.

This method is very handy when you are assigned a creeping line while airborne. It's easy to plan, set up and perform once you have mastered the technique.

You can also fly this pattern to search along a Victor airway. You can perform a similar pattern using the DME; it will be like flying a series of DME arcs.

This method can also be used along a winding river or a road, but the pilot or observer must plan a line that roughly bisects the winding route and then vary the length of the legs as conditions warrant on the ground below.

6. In the GX55, the creeping line is similar to the parallel line pattern, but the starting point is a selected waypoint rather than a grid. The pattern will straddle the center of your flight plan. All the data you need set up this search pattern in the GX55 is on the worksheet:

- Type of Grid and Sectional (US grid, STL).
- Type of pattern (Creeping Line).
- Starting Waypoint (the airport, BMG).
- Spacing (1 nm).
- Direction of Travel (the runway heading, 060°).
- Leg Length (3 nm *).
- Start Side (Right).

* 9.9 nm is the longest leg length you can select on the GX-55.

Additional Information

Search patterns are covered in tasks O-2109 thru O-2115 and may be combined in any fashion. More detailed information and figures on this topic are available in Chapter 11 of the MART.

Practice

Setup: Give the student an expanding square search to plan and perform. The student should have a sectional chart, plotter, and worksheets as needed. A qualified Mission Pilot should be available to assist the trainee.

Brief the pilot. The pilot should fly the pattern long enough to allow the student time to demonstrate proficiency in all aspects of the search. Search altitude, airspeed and track spacing should be selected to match terrain and conditions: 1,000' to 2,000' AGL, 90 knots, three mile legs, and one mile track spacing is recommended.

Depending on the level of proficiency of the student, one or more of these tasks may be practiced simultaneously:

Planning. All mission sorties must be thoroughly planned: this ensures the pilot and crew can accomplish the sortie objectives safely and precisely. Treat each sortie as if it were an actual mission. Each time the student practices a sortie all required paperwork should be completed as part of the drill. The student should sign herself into the mission, ensure that the pilot signs in the aircraft, receive her assignment from you (the briefing officer), plan the sortie, and assist the pilot in completing the flight plan and preliminary mission data portions of the CAPF 104.

The pilot should review the weight and balance, fuel assumptions, and information entered onto the CAPF 104 with the student.

Preflight and pilot briefings. Ensure the student receives pilot safety and mission briefings from the pilot. The student will perform safety assignments as directed (e.g., collision avoidance during taxi and in flight).

Equipment. To the extent possible, the student should operate the communications and navigation equipment. The student should set up and enter information into the equipment (especially the GPS) prior to taxi. [Where necessary for training, the trainer should assist the student in setting up navigation equipment (particularly the GPS) in flight.]

Initial training. Depending on the proficiency and skills of the student, the trainer may need to demonstrate all aspects of a creeping line search. This gives the student time to absorb the information and work on such skills as setting up, entering data, and using the navigational equipment.

For each practice sortie, watch for:

- 1) Proper setup and use of the navigational equipment, particularly the GPS. Ensure that the student does not change any navigational or communications equipment setting without the knowledge of the PIC.
- 2) Proper ATC and CAP FM communications technique and terminology. Initially, have the student tell the pilot and/or trainer what she intends to say *before* she transmits.
- 3) Proper and attentive collision avoidance practices during the critical phases of flight.
- 4) Safety. The student should spend most of her time looking outside the aircraft (see and avoid) when enroute to the search area, and most of her time acting as a scanner while in the search area. Initially, the student will spend too much time with her eyes inside the aircraft (e.g., manipulating the GPS) until she is comfortable and

proficient with the equipment. Get the student into the habit of *not looking inside the aircraft for more than five seconds at a time* to manipulate communications and navigational equipment.

5) Accurate situational awareness at all times.

Evaluation Preparation

Setup: Give the student a creeping line search to plan and perform. The student should have a sectional chart, plotter, and worksheets as needed. A qualified Mission Pilot should be available to assist the trainee during the planning and flying stages.

A search target should be positioned in the search area, if possible.

The pilot will enter and fly the pattern long enough to allow the student to demonstrate proficiency in all aspects of the search. Search altitude, airspeed and track spacing should be selected to match terrain and conditions: 1,000' AGL, 90 knots, three mile legs, and one mile track spacing is recommended.

Run the sortie as it would be during an actual mission. Have the student sign in, sign in the aircraft, and complete all required paperwork. Brief the sortie as if you were the Briefing Officer during a mission.

Brief Student: You are a Mission Observer trainee asked to assist a Mission Pilot in planning and performing a creeping line search.

Evaluation

<u>Performance measures</u>	<u>Results</u>	
1. Sign into the mission.	P	F
2. Receive a sortie briefing, asking questions as necessary.	P	F
3. Assist in planning a creeping line search. Include:		
a. Estimated time enroute, time in the search area, and fuel requirements.	P	F
b. Position coordinates for the entry and exit points (lat/long & VOR radials/cross-radials).	P	F
c. Position coordinates for the legs (lat/long and VOR radials/cross-radials).	P	F
d. Altitude restrictions, obstacles and other hazards (e.g., MTRs and SUAs).	P	F
e. Discuss observer/scanner assignments for all possible combinations.	P	F
4. Assist in filling out the flight plan and preliminary mission data on the CAPF 104.	P	F
5. Receive pilot safety and mission briefings, asking questions as necessary.	P	F
6. Demonstrate and discuss safety during each critical phase of the flight. In particular, demonstrate collision avoidance and enforce sterile cockpit rules.	P	F
7. Demonstrate proper ATC communications.	P	F
8. Setup the CAP FM radio and perform all required radio reports (may be simulated).	P	F
9. Perform the creeping line search. Demonstrate:		
a. Proper use of nav aids (GPS as primary; VOR as backup).	P	F

- | | | |
|--|---|---|
| b. Proper use of radios (ATC as required, and CAP FM radio reports). | P | F |
| c. Proper scanner assignment (may be simulated). | P | F |
| d. Ability to spot the search target (if applicable). | P | F |
| 10. Demonstrate proper attention to fuel management. | P | F |
| 11. Ensure the aircraft is secured at the end of the sortie (ready for next sortie). | P | F |
| 12. Assist in filling out the remainder of the CAPF 104 and debrief the sortie. | P | F |

Student must receive a pass on all performance measures to qualify in this task. If the individual fails any measure, show what was done wrong and how to do it correctly.

O-3001

Discuss Flight Line Marshaller's Responsibilities

CONDITIONS

You are a new/old member on a mission, and are asked to be a Flight Line Marshaller.

OBJECTIVES

- 1. Understand your responsibilities to properly direct, arrange, and park the aircraft for ease of staging flights, safely.
- 2. Understand your responsibilities for assistants and trainees.

TRAINING AND EVALUATION

Training Outline

- 1. When serving as a Flight Line Marshaller you are required to taxi and park the aircraft where they will not interfere with the other aircraft.
 - a. You have the responsibility to direct the aircraft safely on the taxi way and ramp to prevent hitting any objects, damaging it or other aircraft, this requires verifying wing and tail clearances.
 - b. You have the responsibility to assist the pilot to safely refuel his aircraft with the proper fuel minimizing spills.
 - c. You have the responsibility to park the aircraft where it will be safe and not interfere with the operation of other aircraft.
- 2. You are responsible for the safety of your assistants and trainees, assuring they are properly trained
 - a. Verify they know where to stand when directing aircraft, so they will not have to move backward.
 - b. Verify they know the proper hand and arm signals to direct the aircraft.
 - c. Verify that they know how to communicate with you and you with the Flight Line Supervisor for instructions.

Additional Information

More detailed information on this topic is available in the Mission Flight Line Reference Text.

Evaluation Preparation

Setup: None

Brief Student: Explain the necessity and responsibilities of the Flight Line Marshaller.

Evaluation

<u>Performance measures</u>	<u>Results</u>
1. Demonstrate knowledge and responsibilities of working with aircraft on the Flight Line.	P F
2. Demonstrate knowledge and responsibilities for the safety of assistants and trainees.	P F

Student must receive a pass on all performance measures to qualify in this task. If the individual fails any measure, show what was done wrong and how to do it correctly.

State the Five (5) Flight Line Safety Precautions

CONDITIONS

You are a new/old member on a mission, and are asked to be a Flight Line Marshaller.

OBJECTIVES

1. Understand why you need to be alert for sudden dangers, and can't be distracted by these actions.

TRAINING AND EVALUATION

Training Outline

1. While on the flight line the following will cause an accident to happen and cannot be tolerated.
 - a. No saluting.
 - b. NO SMOKING.
 - c. No running.
 - d. No horseplay.
 - e. No walking backwards.

Additional Information

More detailed information on this topic is available in the Flight Line Text and reference material.

Evaluation Preparation

Setup: None

Brief Student: explain what the five safety precautions are and why they can't be tolerated.

Evaluation

Performance measures

1. Name the 5 safety precautions.
2. Explain why they are dangerous.

Results

P F
P F

Trainee must receive a pass on all performance measures to qualify in this task. If the individual fails any measure, show what was done wrong and how to do it correctly.

Identify Requirements for Vehicles on the Flight Line

CONDITIONS

You are a new/old member on a mission, and are asked to be a Flight Line Marshaller.

OBJECTIVES

- 1. Know the safety procedures concerning vehicles on the Flight Line.
- 2. Understand why they should be limited to necessary authorized vehicles only.

TRAINING AND EVALUATION

Training Outline

- 1. Vehicles on the flight line can create a major safety hazard.
 - a. Keep vehicle traffic on the flight line to an absolute minimum. You may not have control over non-CAP vehicles, such as a fuel truck, but keep the CAP vehicles to a minimum.
 - b. If a vehicle is picking up a crew or equipment from an aircraft, have the vehicle approach from the rear after the aircraft has been parked and shut down.
 - c. Vehicle movement should be stopped when there is aircraft movement in the vicinity.
 - d. Vehicles should pull off any established taxiway when an aircraft is moving on it.
 - e. When a vehicle is operated on the ramp area, only communication radios should be turned on. Turn off music or any other distraction that may prevent hearing a running aircraft engine or a warning from personnel.
 - f. The IC must authorize, in writing, the use of vehicles on the flight line.

Additional Information

More detailed information on this topic is available in the Flight Line Reference Text.

Evaluation Preparation

Setup: None.

Brief Student: Explain why you would need a vehicle on the flight line?

Evaluation

<u>Performance measures</u>	<u>Results</u>
1. Give speed limits for vehicle movement on the flight line.	P F
2. Identify flight line driving requirements.	P F
3. Explain how vehicles should entering or leaving the flight line, taxiway or runways.	P F
4. Explain how vehicles should be parking on the flight line.	P F
5. Explain how vehicles should operate under Restricted Visibility.	P F
6. Explain how to use a follow me vehicle.	P F
7. Identify Equipment Requirements for vehicles on the flight line.	P F

Trainee must receive a pass on all performance measures to qualify in this task. If the individual fails any measure, show what was done wrong and how to do it correctly.

O-3004

Discuss Flight Line Security

CONDITIONS

You are a new/old member on a mission, and are asked to be a Flight Line Marshaller.

OBJECTIVES

1. Understand the need to protect CAP assets on the flight line.
2. Understand the need to restrict access to the active flight line.

TRAINING AND EVALUATION
Training Outline

1. When you are present around the flight line you need to stay aware of events around you, particularly those that may be of danger to CAP assets or other aircraft on the field. Your flight line supervisor will brief you on the situation and security concerns for the mission and base you are on
 - a. If CAP aircraft are being fueled in a segregated area you should politely ask any non-CAP people in the area if you can be of assistance. Many flight lines at small fields allow visitors to look at the aircraft tied down, if they have checked in with the FBO. Be polite, they may just want to get a closer look at a CAP aircraft.
 - b. If you are in a situation where CAP aircraft are being parked among other airplanes, other people may be just going to their aircraft.
 - c. If you see someone who may be doing something to a CAP aircraft, and you are not sure who they are, call the Flight Line Supervisor.
2. Be alert and observant. If a situation does not look right to you, report it.
 - a. Someone just hanging around and looking to see if anyone is watching them.
 - b. Tampering with an aircraft or fuel tanks/pumps/trucks.
 - c. Breaking into an aircraft or hanger.

Additional Information

More detailed information on this topic is available in the Flight Line Text and reference material.

Evaluation Preparation

Setup: None

Brief Student: Explain the importance of flight line security.

Evaluation

<u>Performance measures</u>	<u>Results</u>
1. Explain why you would perform flight line security.	P F
2. Explain how you would make the flight line secure.	P F

Trainee must receive a pass on all performance measures to qualify in this task. If the individual fails any measure, show what was done wrong and how to do it correctly.

Discuss Flight Line Hazards

CONDITIONS

You are a new/old member on a mission, and are asked to be a Flight Line Marshaller.

OBJECTIVES

- 1. Know how to watch for hazards.
- 2. Be aware that safety is the most important job.

**TRAINING AND EVALUATION
Training Outline**

- 1. During flight line operations various hazards are encountered. Other factors involve the variety of weather conditions, the different conditions during day and night operations, mission priorities, and the various aircraft systems. Aircraft and flight line areas present potential fire and explosion hazards such as Gasoline, oil, cleaning solvents, etc. is typical of these hazards. Other hazards include:
 - a. Cell phones and pagers are a distraction and can be an ignition source. Do not wear either while working on the flight line or refueling.
 - b. Antennas, static wicks, pitot tubes, and other projections.
 - c. Lightning.
 - d. Tripping hazards such as cables, tie-down ropes or chains, fuel hoses and ladders.
 - e. Slipping hazards such as oil, hydraulic fluid, grease spills, and weather conditions.
 - f. Noise can cause hearing loss, interference with speech communications, and disruption of job performance.
 - g. The Flight Line Supervisor will ensure all personnel are aware of potentially flammable fuel vapor areas. Fuel vapors are heavier than air and will settle to ground level and enter below ground areas. Some examples of hazardous fuel vapor areas are fuel pits below ground level, and areas within 10 feet of aircraft fuel vent systems and fuel spills.
 - h. Medical conditions as dehydration and fatigue should be treated as hazards too. Both can result in unsafe operations and poor performance
- 2. The primary concern during any flight line operation is SAFETY. No activity is important enough that the safety of any personnel should be compromised, for any reason. All personnel are authorized to stop any activity on a flight line if any actual or perceived unsafe activity is occurring. Aircraft marshaller's should contact the Flight Line Supervisor, Mission Safety Officer or IC if there is any concern over safety. Safety is always your #1 PRIORITY.

Additional Information

More detailed information on this topic is available in the Flight Line Text and reference material.

Evaluation Preparation

Setup: None.

Brief Student: Explain the hazards of the flight line.

Evaluation

<u>Performance measures</u>	<u>Results</u>
1. Identify hazards associated with flight line operations?	P F
2. Discuss how to minimize the hazards?	P F

Student must receive a pass on all performance measures to qualify in this task. If the individual fails any measure, show what was done wrong and how to do it correctly.

Marshall an Aircraft

CONDITIONS

You are a new/old member on a mission, and are asked to be a Flight Line Marshaller.

OBJECTIVES

1. Know how to use the proper hand and arm signals to direct the aircraft.

TRAINING AND EVALUATION

Training Outline

1. The hand signals taught in this course are universal and are used by all aviation services. REMEMBER some pilots may not be familiar with these signals.
 - a. These signals are designed for use by the marshaller, using flashing lights when necessary, to facilitate observation by the pilot, and facing the aircraft in a position to the pilots left.
 1. For fixed wing aircraft – within view of the pilot at all times.
 2. For helicopters – where the marshaller can best be seen by the pilot.
 - b. The meaning of the relevant signals remains the same if batons, illuminated wands or flashlight's are used.
 - c. The aircraft engines are numbered, for the marshaller facing the aircraft, from right to left (i.e., # 1 engine being the port or left outer engine).
2. Marshalling signals are a very important part of any flight line operation, and the knowledge of their meaning by both aircrews and marshaller's are imperative. The following signals will be used on all CAP flight lines to provide a safe environment for both aircraft and personnel.

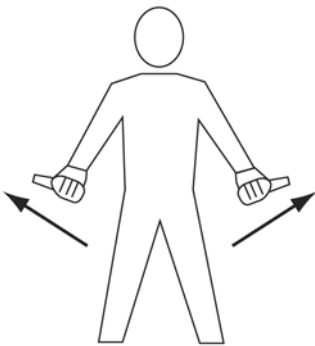

Outward motion with
Thumbs - **PULL
CHECKS**



Circular motion of right hand
at head level with left arm
pointing to engine. **START
ENGINE**



Raise arm, with fist
clenched, horizontally in
front of body, and then
extend fingers.
RELEASE BRAKE



Thumb up
OK or YES



Thumb down
**NOT OK or
NO**



Arms above head in vertical
position with palms facing
inward. **THIS MARSHALLER**

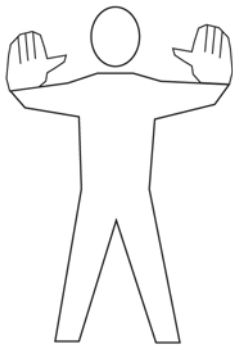

Arms a little aside, palms facing backwards and repeatedly moved upward and backward from shoulder height. **MOVE AHEAD**

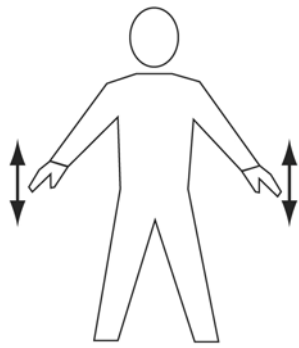

Arms down with palms toward ground, then moved up and down several times. **SLOW DOWN**

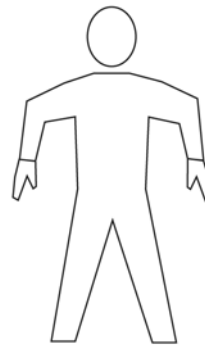

Arms extended with forearm perpendicular to ground. Palms facing body. **HOT BRAKES**

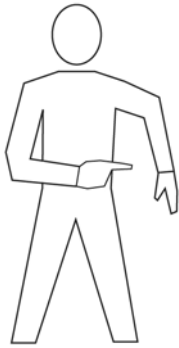

Arms extended with forearm perpendicular to ground. Palms facing body. Gesture indicates right side of aircraft. **HOT BRAKES-RIGHT SIDE**

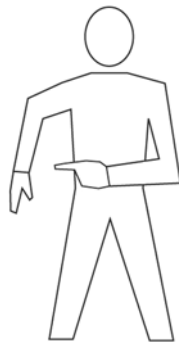

Arms extended with forearm perpendicular to ground. Palms facing body. Gesture indicates left side of aircraft. **HOT BRAKES-LEFT SIDE**



Waiving arms over head. **EMERGENCY STOP**



Right or left arm down, other arm moved across the body and extended to indicate direction of next marshaller. **PROCEED TO NEXT MARSHALLER**

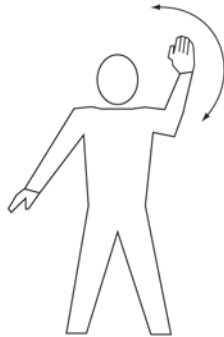

Point right arm downward, left arm repeatedly moved upward-backward. Speed of arm movement indicating rate of turn. **TURN TO THE LEFT**



Point left arm downward, right arm repeatedly moved upward-backward. Speed of arm movement indicating rate of turn. **TURN TO THE RIGHT**



Arms crossed above the head, palms facing forward. **STOP**

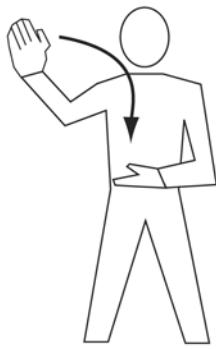

Make a chopping motion with one hand slicing into the flat and open palm of the other hand. Number of fingers extended on left hand indicates affected engine. **FEATHER/FUEL SHUT OFF**

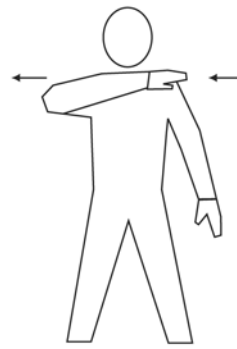

Either arm and hand level with shoulder, hand moving across throat, palm downward. **CUT ENGINES**

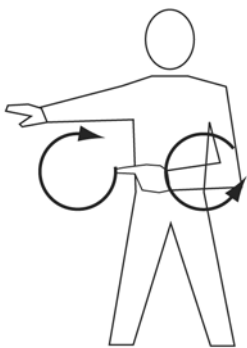

Make rapid horizontal figure-of-eight motion at waist level with either arm, pointing at source of fire with the other. **FIRE ONBOARD**



Raise arm and hand, with fingers extended horizontally in front of the body, then clench fist. **ENGAGE BRAKE**

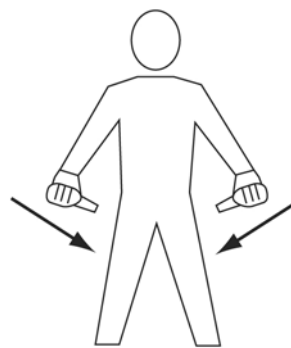

Inward motion with Thumbs - **INSERT CHOCKS**

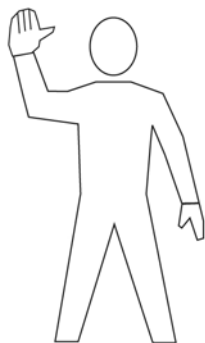

Right arm raised; elbow shoulder height; palm forward. **MARSHALLER FINISHED**

Additional Information

More detailed information on this topic is available in the Flight Line Text and reference material.

Evaluation Preparation

Setup: Provide an aircrew and aircraft for this evaluation. Set up an obstacle course whereby the student and/or students can demonstrate all the proper hand signals.

Brief Student: Demonstrate the proper hand and arm signals.

Evaluation

<u>Performance measures</u>	<u>Results</u>
1. Demonstrate all of the required hand and arm signals.	P F

Trainee must receive a pass on all performance measures to qualify in this task. If the individual fails any measure, show what was done wrong and how to do it correctly.

Be a Wing Walker

CONDITIONS

You are a new/old member on a mission, and are asked to be a Flight Line Marshaller.

OBJECTIVES

- 1. Know how to be a wing walker and how to properly help the tower.

TRAINING AND EVALUATION

Training Outline

- 1. Since you will be moving aircraft in and out of congested spaces, you should always have another person act as your wing walker.
 - a. A wing walker is essential, because it is impossible for the marshaller to see all the extremities of the aircraft from the marshalling position. Using a wing walker is most important when marshalling an aircraft into a close parking spot.
 - b. As the marshaller, you have the ultimate responsibility for the aircraft. If you lose contact with your wing walker, or you do not understand the directions being given by the wing walker, stop immediately. Verify that you have adequate clearance.
 - c. If you are working as a wing walker, always maintain eye contact with the marshaller. The same hand signals that you used to direct a pilot should be used to direct the person marshalling. Use crisp and distinct hand signals and vocalize the situation if necessary. Do not hesitate to call out "STOP" if you see a problem or are unsure of the clearances.
- 2. Since you will be moving aircraft in and out of congested spaces, you should always have another person act as your wing walker.
 - a. A wing walker is essential, because it is impossible for you to see all the extremities of the aircraft from the tow position. Using a wing walker is most important when pushing an aircraft back into a hangar or another parking spot.
 - b. As the tow operator, you have the ultimate responsibility for the aircraft. If you lose contact with your wing walker, or you do not understand the directions being given by the wing walker, stop immediately. Verify that you have adequate clearance.
 - c. If you are working as a wing walker, always maintain eye contact with the tower. The same hand signals that you used to direct a pilot should be used to direct the person towing. Use crisp and distinct hand signals and vocalize the situation if necessary. Do not hesitate to call out "STOP" if you see a problem or are unsure of the clearances.
- 3. Since we do not have tugs, a tow team is necessary to help both the tower and wing walkers to get our aircraft from one point to another. In some cases the tower can move an aircraft by themselves, but help makes the move easier and safer.
 - a. The tow team will be properly positioned at aircraft push-points.
 - b. Their only job is to push. This frees the tower and wing walker to doing only their assigned jobs.
 - c. The tow team will carry chocks during the towing operation in case of an emergency.
 - d. After stopping, hold the aircraft in position until it is properly chocked.

Additional Information

More detailed information on this topic is available in the Flight Line Reference Text.

Evaluation Preparation

Setup: Parked aircraft, three wing walkers

Brief Student: Position a wing walker at each wing tip and the tail.

Evaluation

<u>Performance measures</u>	<u>Results</u>
1. Demonstrate the ability to be a wing walker?	P F
2. Demonstrate the ability to serve as a tow team member?	P F

Trainee must receive a pass on all performance measures to qualify in this task. If the individual fails any measure, show what was done wrong and how to do it correctly.

Perform Aircraft Startup Procedures

CONDITIONS

You are a new/old member on a mission, and are asked to be a Flight Line Marshaller.

OBJECTIVES

- 1. Know how to use the correct procedures for aircraft startup.

TRAINING AND EVALUATION

Training Outline

- 1. The following outlines procedures used during engine start up. The marshaller will be positioned within view of the pilot at all times.
 - a. Engine starting procedures should be included in aircrew briefing.
 - b. The pilot should not start the engine without a marshaller in position.
 - c. Check that chocks are removed before engine start.
 - d. Before starting the engine, the pilot will let the marshaller know they are ready by holding their hand out the window, moving their hand up and down, and stating "Clear Prop". The marshaller will the "Clear Prop" warning with a 'thumbs up' sign. This signal lets the pilot know the area is clear and the marshaller is ready for engine start.
 - e. During night operations flashing of the landing lights may be substituted for the hand signals.

Note: Every aircrew will need time to go through their checklist before moving from one point in this procedure to the next. Marshallers will need to be patient and give the aircrew time to complete their checklists.

Additional Information

More detailed information on this topic is available in the Flight Line Text and reference material.

Evaluation Preparation

Setup: A parked aircraft

Brief Student: Demonstrate the proper place to stand and give the correct signal for 'Engine Startup'.

Evaluation

Performance measures

Results

- 1. Demonstrate the ability to properly work with an aircrew during aircraft startup.

P F

Trainee must receive a pass on all performance measures to qualify in this task. If the individual fails any measure, show what was done wrong and how to do it correctly.

Perform Aircraft Taxi Procedures

CONDITIONS

You are a new/old member on a mission, and are asked to be a Flight Line Marshaller.

OBJECTIVES

1. Know how to use the correct procedures for taxiing an aircraft.

TRAINING AND EVALUATION

Training Outline

1. The following outlines procedures used to taxi the aircraft. The marshaller will be positioned within view of the pilot at all times.
 - a. Taxi procedures should be included in aircrew briefing.
 - b. The pilot should not begin to taxi without the marshaller's permission.
 - c. When the pilot is ready to taxi, they will turning their pulse light on or flashing their landing/taxi light.
 - d. The marshaller will give the pilot permission to taxi using standard taxi signals.
 - e. The pilot may then taxi to designated run-up area.
 - f. During Taxi operations if you see an aircraft taxiing too fast, signal them to slow down by using the appropriate marshalling signal.
2. CAP personnel marshalling aircraft must position themselves to meet the following requirements.
 - a. Never position yourself in the path of an oncoming aircraft
 - b. Never position yourself in a location where any part of an aircraft will pass over you
 - c. Never walk backwards on the ramp
 - d. Never run on the ramp
 - e. Always marshal aircraft entering a congested ramp under CAP control
 - f. Always get enough personnel to control aircraft movement without compromising safety
 - g. Always position yourself where you can maintain direct eye contact with the pilot-in-command (ten feet to the pilot's left of the left wing tip and far enough in front of the aircraft to allow for a turn in front of you is ideal)
 - h. Always hand the aircraft off to the next marshaller before the pilot losses sight of you.
3. Careful planning of the number of resources and their position can accomplish this with ease. Suggested marshaller positioning is shown on the following diagrams for departing (fig. 1) and arriving (fig. 2) aircraft.

Figure 1

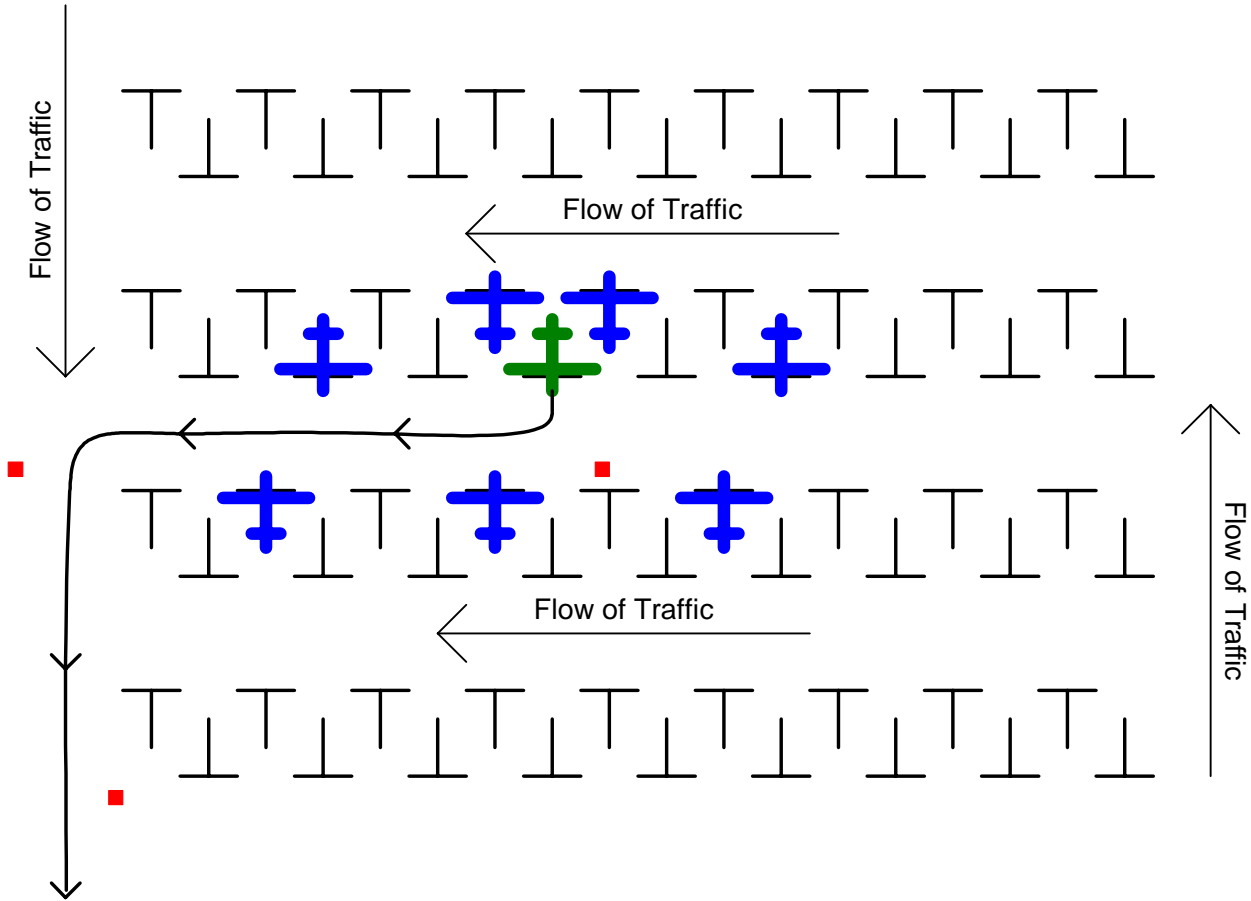

Departing aircraft are marshaled out of their spot and released once clear of the congested area.

Figure 2

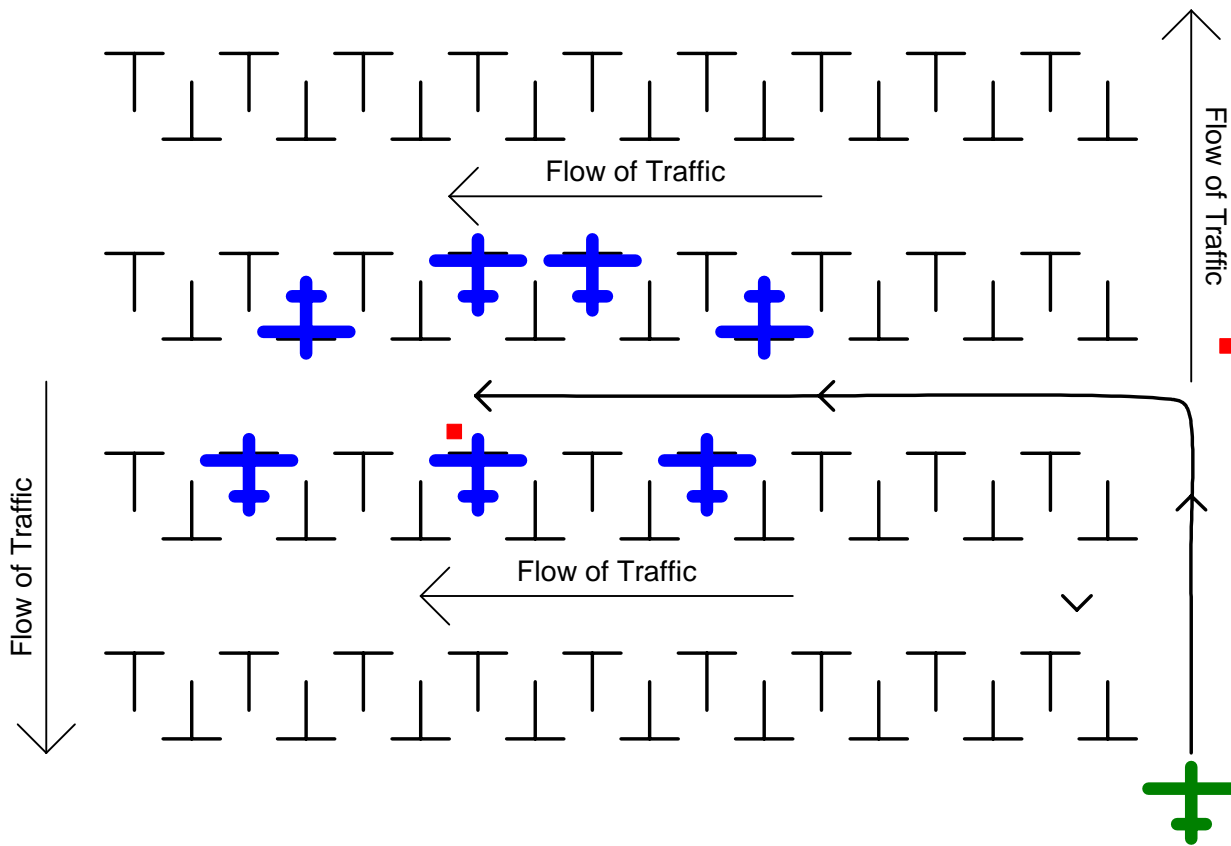

Arriving aircraft are marshaled into place just passed their assigned parking spot and pushed back into place.

Additional Information

More detailed information on this topic is available in the Flight Line Text and reference material.

Evaluation Preparation

Setup: Working with an aircrew and aircraft, let each student perform required taxi procedures

Brief Student: Demonstrate the correct signal for taxiing an aircraft.

Evaluation

Performance measures

1. Demonstrate the ability to taxi an aircraft.

Results

P F

Trainee must receive a pass on all performance measures to qualify in this task. If the individual fails any measure, show what was done wrong and how to do it correctly.

O-3010

Perform Aircraft Shutdown & Chocking Procedures

CONDITIONS

You are a new/old member on a mission, and are asked to be a Flight Line Marshaller.

OBJECTIVES

- 1. Know the correct procedures for engine shutdown.
- 2. Know the correct procedures for chock the wheels.

TRAINING AND EVALUATION

Training Outline

- 1. The following outlines procedures used to park and shut down the aircraft. The marshaller will be positioned within view of the pilot at all times.
 - a. The pilot should follow the taxi plan and marshallers directions (with help from wing walkers and aircrew as needed).
 - b. The pilot should indicate engine shutdown by showing the marshaller the aircraft keys.
 - c. The marshaller will indicate when chocks have been installed, and at that time the pilot should release the parking brake.
 - d. The aircrew on all aircraft will perform a post-flight inspection after each sortie.
- 2. After the engine is shut down and the pilot shows their keys, the aircraft should be chocked.
 - a. Have another person place a chock in front of and behind the main landing gear wheels.
 - b. Signal chocks in place.
 - c. Signal release parking brake.
 - d. After completing chocking procedures for the aircraft, marshallers are free to move to their next assignment
- 3. Wheel chocks will be placed fore and aft of the main landing gear or as specified in applicable aircraft manual.

Additional Information

More detailed information on this topic is available in the Flight Line Reference Text.

Evaluation Preparation

Setup: parked aircraft, another marshaller.

Brief Student: Demonstrate the signal to shutdown the engine, chock wheels, release parking brake.

Evaluation

<u>Performance measures</u>	<u>Results</u>
1. Demonstrate proper shutdown procedures?	P F
2. Demonstrate proper chocking procedures?	P F

Trainee must receive a pass on all performance measures to qualify in this task. If the individual fails any measure, show what was done wrong and how to do it correctly.

Tie Down an Aircraft

CONDITIONS

You are a new/old member on a mission, and are asked to be a Flight Line Marshaller.

OBJECTIVES

- 1. Know how to properly tie down an aircraft.

TRAINING AND EVALUATION

Training Outline

- 1. This will be accomplished according on type of aircraft. When ropes are used, they will be tied to designated mooring fittings on aircraft. Normally a bowline knot will be used to prevent slippage and to provide secure fastening. Just enough slack should be allowed to prevent excessive stress on the wings, fittings and rope due to tires and strut expansion or deflation and to prevent contraction of the tie-down ropes due to moisture or wetness. The mooring points on the ground should be as close as possible directly under the respective mooring points on the aircraft. This diagram shows a vertical anchor using straight link coil chain for connection between the wire rope and aircraft wing. One link on the free end is then passed through a link of the taut portion and a safety snap is used to keep the link from passing back through. Any load on the chain is borne by the chain itself instead of the snap.

- 2. The following will review procedures as outlined in CAPR 66-1 paragraph 15 (1 February 2000).

"15. Storage and Tie-Down. Region and wing commanders are responsible for assuring that all possible preventive measures are taken to safeguard corporate 6 CAPR 66-1 (E) aircraft from wind and weather damage. Aircraft should be kept in a hangar whenever possible. Aircraft parked in the open shall be tied down at the three approved tie-down points (wings and tail) and securely chocked to prevent wind damage. The control lock shall be installed. Aircraft in extended outside storage shall be tied at four points (nose, wings, and tail).

a. Tie-Down Anchors. There are many methods of anchoring tie-downs. Satisfactory tie-down anchors may be constructed as shown at Attachment 3. Variations may be necessary when local conditions dictate.

b. Tie-Down Ropes. Tie-down ropes with tensile strength of 3,000 pounds or greater shall be used. Nylon or dacron tie-down ropes are recommended. Refer to Attachment 3 for rope specifications.

c. Tie-Down Chains. Chains shall not be used directly from aircraft mooring points to an anchor point because of excessive impact loads on wing spars. When chain tie-downs are used, they shall be attached to wire rope anchors as depicted in Attachment 3. Wire rope anchors are constructed of two continuous lengths of parallel wire rope passed through the anchor points. The tie-down chains shall be attached to the wire rope with round pin galvanized anchor shackles. This allows the chains to float along the wire rope to reduce impact loads. Chain links used for tie-down must be at least 5/16-inch steel and a proof load of 2,720 pounds and breaking load of 5,440 pounds. All fittings must be equally as strong and chains should be secured without slack.

d. Spoilers. In high wind areas, the use of sandbags, or spoiler boards as described in FAA advisory circular 20-35C, are recommended."

Additional Information

More detailed information on this topic is available in the Flight Line Text and reference material.

Evaluation Preparation

Setup: Parked aircraft, tie down ropes, and anchors.

Brief Student: Demonstrate how to properly tie down the aircraft.

Evaluation

<u>Performance measures</u>	<u>Results</u>
1. Demonstrated how to properly tie down an aircraft.	P F

Student must receive a pass on all performance measures to qualify in this task. If the individual fails any measure, show what was done wrong and how to do it correctly.

Demonstrate Proper Ground Safety Observer Techniques

CONDITIONS

You are a new/old member on a mission, and are asked to be a Flight Line Marshaller.

OBJECTIVES

1. Understand how to plan where to stand to direct the aircraft, so you can see and be easily seen by the pilot, and you won't have to move while the aircraft taxi.
2. How to assist the Flight Line Supervisor in planning the best parking areas, and taxiway paths to use.

TRAINING AND EVALUATION

Training Outline

1. Determine the proper position to stand, where you can be seen and not have to move as aircraft are directed to the ramp area.
 - a. The proper place to stand is on the outside corner of a taxiway intersection. The aircraft will taxi off the runway toward you and turn the direction you give them, and not cross the centerline.
 - b. When the aircraft is approaching the ramp area, contact the aircraft by radio to find out if the pilot is going to refuel before parking the aircraft?
 - c. Direct the aircraft to the refueling area first, and then back to the staging area to park.
2. Determine the proper place to stand when parking an aircraft.
 - a. The proper place to stand is ahead of the aircraft, off center; on the side opposite from the direction you want the pilot to turn.
 - b. Never stand directly in front of the prop, and hope the brakes hold.
 - c. Park the aircraft on the paved part of the ramp area, if possible.
3. Try to choose taxiway paths that don't cross or traffic goes both ways.
 - a. Use different entry and exit from the parking ramp area.
 - b. Use different sections of taxiways so the traffic will be one way.

Additional Information

More detailed information on this topic is available in the Flight Line Reference Text.

Evaluation Preparation

Setup: None.

Brief Student: Explain safety procedures for use on the flight line and what to watch for.

Evaluation

<u>Performance measures</u>	<u>Results</u>
1. Discussed safety measures?	P F
2. Demonstrated the correct position to stand when marshalling aircraft?	P F

Trainee must receive a pass on all performance measures to qualify in this task. If the individual fails any measure, show what was done wrong and how to do it correctly.

DEMONSTRATE THE ABILITY TO FUEL AN AIRCRAFT

CONDITIONS

You are a new Flight Line Marshaller trainee and need to learn to interact with aircraft and aircrews on the flight line to refuel aircraft safely and efficiently to support mission operations.

OBJECTIVES

The student will be able to safely fuel a CAP aircraft for use on a mission.

TRAINING AND EVALUATION

Training Outline

1. Safe expeditious work is necessary for a smooth running flight line. Fueling aircraft is one of the primary duties of flight line personnel.
 - a. Never approach an aircraft while the prop is turning
 - b. Make sure the chocks are in place to prevent the aircraft from moving while you are working.
 - c. Ground the aircraft to the fueling pump before beginning your work
 - d. Use foot/hand holds to access the fueling points
 - e. Only add fuel to the level indicated. DO NOT OVERFILL.
 - f. Be mindful of spillage as aviation fuels present environmental hazards
 - g. Replace the fuel caps before moving away from the fueling points.
 - h. Document how much fuel was taken on

Additional Information

More detailed information on this topic is available in the Flight Line Reference Text.

Evaluation Preparation

Setup: Present the student with several opportunities to interact with flight crews and refuel aircraft.

Brief Student: Safety and efficiency are requirements for Flight Line Operations. Utilize the briefing and checklist to refuel and aircraft.

Evaluation

Performance Measures

Results

The individual successfully refuels an aircraft:

1. Approaches the aircraft safely.	P	F
2. Ensures aircraft is chocked	P	F
3. Grounds the aircraft at the fuel pump	P	F
4. Uses appropriate hand and footholds for accessing fueling points	P	F
5. Adds fuel to the levels indicated without spilling	P	F
6. Caps fuel tanks	P	F
7. Documents fuel dispersed	P	F

Student must receive a pass on all performance measures to qualify in this task. If the individual fails any measure, show what was done wrong and how to do it correctly.

O-3014
DEMONSTRATE KNOWLEDGE OF FLIGHT LINE SECURITY

CONDITIONS

You are a new Flightline Marshaller trainee. Flight line safety and security is your number one priority.

OBJECTIVES

The student should understand the security concerns and requirements for CAP when operating on a flightline.

TRAINING AND EVALUATION

Training Outline

1. Safe expeditious work is necessary for a smooth running flight line. Discerning who should and should not be on the flight line and making sure they enter and leave safely is necessary for flight line security.
 - a. People on the flight line should have the proper uniforms and equipment.
 1. Eye and ear protection
 2. Red or Orange vest
 3. Highly visible marshalling battons
 - b. If personnel on the flight line are not Marshallers or aircrew members heading to an aircraft, advise the members to stay behind the caution line.
 - c. Monitor personnel moving around aircraft to ensure they are conducting themselves safely and efficiently.
 - d. Vehicles that belong on the flight line are easily identified-work vehicles, fuel trucks, and towing equipment.
 - e. Other vehicles or personnel should be reported to the Flightline Supervisor.

Additional Information

More detailed information on this topic is available in the Flight Line Reference Text.

Evaluation Preparation

Setup: Present the student with several opportunities to interact with flight crews, bystanders, and other mission personnel.

Brief Student: Utilize the briefing and checklist to maintain security on the flight line.

Evaluation

<u>Performance Measures</u>	<u>Results</u>	
Visitors to the flight line are met and briefed; crews are delivered safely to their aircraft.		
1. Members are provided with ear protection if they do not have it	P	F
2. Members are advised to stay behind the caution line while the flightline is active	P	F
3. Nonessential personnel or dangerous activity is reported to the Flightline Supervisor	P	F
4. POV's and non-mission or non-flight line vehicles are noted and reported to the Flightline Supervisor	P	F

Student must receive a pass on all performance measures to qualify in this task. If the individual fails any measure, show what was done wrong and how to do it correctly.

O-3101

Discuss Flight Line Supervisor Responsibilities

CONDITIONS

You are a new/old member on a mission, and are asked to be a Flight Line Supervisor.

OBJECTIVES

- 1. Understand your responsibilities for the safety of the aircraft on the flight line.
- 2. Understand your responsibilities for the safety of the personnel assisting on the flight line.

TRAINING AND EVALUATION

Training Outline

- 1. You are the person who sets up the ramp and taxiways that will be used by the mission aircraft.
 - a. Arrange the use to minimize paths crossing at intersections.
 - b. Arrange the taxiway use to one-way traffic as much as possible.
 - c. If you can't avoid having two-way traffic on a taxiway post a marshaller at each end for control.
- 2. For safety of the trainees put them, as much as possible, with an experienced person.
 - a. The marshaller can explain where to stand and what to signal the aircraft.
 - b. During slow periods they can demonstrate the signals to the trainee.

Additional Information

More detailed information on this topic is available in the Flight Line Reference Text.

Evaluation Preparation

Setup: None

Brief Student: Have the trainee explain the responsibilities of the Flight Line Supervisor.

Evaluation

<u>Performance measures</u>	<u>Results</u>
1. Demonstrate knowledge and responsibilities of the Flight Line Supervisor.	P F
2. Demonstrate knowledge and responsibilities for the safety of assistants and trainees.	P F

Trainee must receive a pass on all performance measures to qualify in this task. If the individual fails any measure, show what was done wrong and how to do it correctly.

Discuss How to Set Up A Flight Line

CONDITIONS

You are a new/old member on a mission, and are asked to be a Flight Line Supervisor.

OBJECTIVES

- 1. Understand how to best use the available marshallers and trainees to accomplish the mission.
- 2. Understand how to best utilize the ramp and taxiways to avoid 'Hot Spots'.

TRAINING AND EVALUATION

Training Outline

- 1. From a survey of the airport and a discussion with the FBO, locate the parking ramp area that you can use for the mission aircraft and what runway and taxiways are available.
 - a. Discuss with the Air Branch Director, how many aircraft they are expecting.
 - b. Discuss with the FBO where the refueling point is and how it will be accomplished.
 - c. Make sure you will have enough equipment and space to chock and tie down the expected aircraft.
- 2. Try to arrange the aircraft taxi patterns to avoid crossing or two-way traffic on the taxiways.
 - a. Use different entrance and exit points to the ramp area, to prevent paths crossing.
 - b. The taxiway may have to be divided for use in take offs and landings to keep the aircraft going the same direction on that portion.
 - c. Make sure that there are marshallers are posted at all points that require control for safety

Additional Information

More detailed information on this topic is available in the Flight Line Reference Text.

Evaluation Preparation

Setup: Airport map or diagram, pencil and paper.

Brief Student: Explain how to use the taxiways, ramp parking area, refueling area, for the safest operation.

Evaluation

<u>Performance measures</u>	<u>Results</u>
1. Demonstrate how to best use the available marshallers and trainees to accomplish the mission	P F
2. Demonstrate how to arranged parking spots for minimum interference with other aircraft	P F

Trainee must receive a pass on all performance measures to qualify in this task. If the individual fails any measure, show what was done wrong and how to do it correctly.

Discuss Flight Line Organization

CONDITIONS

You are a new/old member on a mission, and are asked to be a Flight Line Supervisor.

OBJECTIVES

- 1. Understand what kind of organization is needed to operate a successful, safe flight line.
- 2. Understand how to use the trainees without affecting their safety.

TRAINING AND EVALUATION

Training Outline

- 1. The organization of the flight line depends on the assets available:
 - a. How many aircraft are at the mission?
 - b. How many non-CAP aircraft are on the ramp area?
 - c. How the taxiways and ramp area are oriented?
 - d. How much activity does the airport have?
 - e. What services the FBO can provide?
- 2. The number of personnel available
 - a. How many are qualified?
 - b. How many are trained?
 - c. How many are untrained?

Additional Information

More detailed information on this topic is available in the Flight Line Reference Text.

Evaluation Preparation

Setup: None

Brief Student: Explain how you adjust the organization to fit the needs?

Evaluation

<u>Performance measures</u>	<u>Results</u>
1. Discuss airport size and how busy it is?	P F
2. Discuss how many aircraft and how many personnel?	P F

Trainee must receive a pass on all performance measures to qualify in this task. If the individual fails any measure, show what was done wrong and how to do it correctly.

Coordinate Activities With Local FBO

CONDITIONS

You are a new/old member on a mission, and are asked to be a Flight Line Supervisor.

OBJECTIVES

- 1. Understand that you will be working in the FBO's area and must be a minimum interference with his operation.
- 2. There must be an understanding what functions each group is expected to perform.

TRAINING AND EVALUATION

Training Outline

- 1. Discuss what part of the ramp you can use to park the mission aircraft on.
 - a. Check with Air Branch Director on how many aircraft they expect?
 - b. Try to use a part of the ramp that has easy access to the taxiways for take off and landing.
 - c. Consider the taxi pattern for refueling.
- 2. Discuss how and where the refueling will be done.
 - a. The FBO may use a refueler and bring the fuel to your parked aircraft.
 - b. There may be a fixed self-service fuel pump that the aircraft will have to go to.
 - c. The FBO may let you use the Wing credit card and pay for all the POL used with one transaction.
- 3. Discuss how busy the FBO thinks the airport will be.
 - a. There maybe scheduled commuter or corporate air that could take-up part of the ramp area.
 - b. Make contingency plans for more or less aircraft.
 - c. Discuss who the FBO's point of contact is and how to contact them.

Additional Information

More detailed information on this topic is available in the Flight Line Reference Text.

Evaluation Preparation

Setup: None.

Brief Student: Explain what things should be arranged ahead of time.

Evaluation

<u>Performance measures</u>	<u>Results</u>
1. Discuss what needs to be coordinated with the FBO?	P F
2. Discuss how you can contact the FBO's point of contact?	P F

Trainee must receive a pass on all performance measures to qualify in this task. If the individual fails any measure, show what was done wrong and how to do it correctly.

Coordinate Activities With airport Administration and Security

CONDITIONS

You are a new/old member on a mission, and are asked to be a Flight Line Supervisor.

OBJECTIVES

1. Understand what the airports activities are and what the security procedures are to minimize interference with their operation.
2. Discuss what your operation is going to be and determine where and how to minimize their interference with your flight line operation.

TRAINING AND EVALUATION

Training Outline

1. Determine when the scheduled aircraft will arrive and depart.
 - a. Where they will taxi and park, load and unload passengers, cargo or refuel.
 - b. Try to find a part of the ramp that is adequate for your operation and won't interfere with the airport operations.
2. Discuss the airport security procedures so you will be in compliance.
 - a. Do vehicles on the flight line have to have an inspection or pass?
 - b. Are there any quarantined or restricted areas?
 - c. Are there terminal access areas that are off limits?

Additional Information

More detailed information on this topic is available in the Flight Line Reference Text.

Evaluation Preparation

Setup: None.

Brief Student: Explain the operational and security aspects that need to be coordinated on.

Evaluation

<u>Performance measures</u>	<u>Results</u>
1. Discuss the operational effects on your flight line operation.	P F
2. Discuss the security effects on your flight line operation.	P F

Trainee must receive a pass on all performance measures to qualify in this task. If the individual fails any measure, show what was done wrong and how to do it correctly.

Coordinate Activities With Local Fire Department

CONDITIONS

You are a new/old member on a mission, and are asked to be a Flight Line Supervisor.

OBJECTIVES

- 1. Understand that you have to be prepared in case there is a fire at the airport.
- 2. If an accident happens that is not the time to find out how to contact the fire department.

TRAINING AND EVALUATION

Training Outline

- 1. If you do not have a fire department on the airport try to arrange with the local fire department to make a fire truck available during your flying hours and if not, make sure you know the local procedures for getting them out to the airport.
 - a. Know where the fire extinguishers are located on the airport.
 - b. Know where the emergency equipment is located.
 - c. Know who has had fire-fighting training.

Additional Information

More detailed information on this topic is available in the Flight Line Reference Text.

Evaluation Preparation

Setup: None.

Brief Student: Explain the importance of being prepared for a fire emergency.

Evaluation

<u>Performance measures</u>	<u>Results</u>
1. Discuss how to find out the fire department that has jurisdiction at a local airport.	P F
2. Discuss how to contact them from the airport.	P F

Trainee must receive a pass on all performance measures to qualify in this task. If the individual fails any measure, show what was done wrong and how to do it correctly.

Coordinate Activities With Local Hospital and/or EMT Operators

CONDITIONS

You are a new/old member on a mission, and are asked to be a Flight Line Supervisor.

OBJECTIVES

1. Understand that there could be an aircraft accident and someone could be injured.
2. There could be a life threatening accident that knowing how to contact the rescue squad would make a difference.

TRAINING AND EVALUATION

Training Outline

1. If you do not have a ambulance & EMT services on the airport try to arrange with the local jurisdiction to make one available during your flying hours and if not, make sure you know the local procedures for getting them out to the airport
 - a. Know where the Emergency First aid supplies are located at the airport.
 - b. Know who has EMT or first aid training.
 - c. Know how to contact the rescue squad and where the closes hospital is.

Additional Information

More detailed information on this topic is available in the Flight Line Reference Text.

Evaluation Preparation

Setup: None.

Brief Student: Explain the importance of being prepared for a life-threatening emergency.

Evaluation

<u>Performance measures</u>	<u>Results</u>	
1. Discuss how to find the hospital & rescue squad that has jurisdiction at a local airport.	P	F
2. Discuss how to contact them from the airport.	P	F

Trainee must receive a pass on all performance measures to qualify in this task. If the individual fails any measure, show what was done wrong and how to do it correctly.

Survey airport For The Best Parking Areas and Taxi Routes

CONDITIONS

You are a new/old member on a mission, and are asked to be a Flight Line Supervisor.

OBJECTIVES

1. Understand how plan taxi routes to the ramp for parking and refueling.
2. Understand how to plan taxi routes to engine run-up area, to and from runway for take off and landing.

TRAINING AND EVALUATION

Training Outline

1. Smaller airports don't have a map of the taxiways and ramp area that you can use to lay out the parking spaces and taxi routes. You will have to make your own to use for briefings and admin.
 - a. You can sketch from the large wall map or photo.
 - b. You can take some rough measurement and sketch one.
 - c. You can draw a rough sketch free hand.
2. Use the windsock to determine which runway to use or ask the FBO.
 - a. Try to layout the taxi routes for easy access to and from the ramp with minimum crossing and two-way traffic.
 - b. If it is necessary to cross or have two-way traffic post a marshaller on each route.
 - c. Determine where the refueling point is located and plan how to go to and from it, if needed.

Additional Information

More detailed information on this topic is available in the Flight Line Reference Text.

Evaluation Preparation

Setup: Have pencil, paper, ruler or drafting scale, note pad and compass.

Brief Student: Draw a sketch of a flight line plan from an airport directory or a local airport. Discuss how you would go about a survey.

Evaluation

<u>Performance measures</u>	<u>Results</u>
1. Make a usable sketch?	P F
2. Explain some of the points to look for during the survey?	P F

Trainee must receive a pass on all performance measures to qualify in this task. If the individual fails any measure, show what was done wrong and how to do it correctly.

Survey airport For The Best Parking Areas and Taxi Routes

CONDITIONS

You are a new/old member on a mission, and are asked to be a Flight Line Supervisor.

OBJECTIVES

- 1. Understand how plan taxi routes to the ramp for parking and refueling.
- 2. Understand how to plan taxi routes to engine run-up area, to and from runway for take off and landing.

TRAINING AND EVALUATION

Training Outline

- 1. Smaller airports don't have a map of the taxiways and ramp area that you can use to lay out the parking spaces and taxi routes. You will have to make your own to use for briefings and admin.
 - a. You can sketch from the large wall map or photo.
 - b. You can take some rough measurement and sketch one.
 - c. You can draw a rough sketch free hand.
- 2. Use the windsock to determine which runway to use or ask the FBO.
 - a. Try to layout the taxi routes for easy access to and from the ramp with minimum crossing and two-way traffic.
 - b. If it is necessary to cross or have two-way traffic post a marshaller on each route.
 - c. Determine where the refueling point is located and plan how to go to and from it, if needed.

Additional Information

More detailed information on this topic is available in the Flight Line Reference Text.

Evaluation Preparation

Setup: Have pencil, paper, ruler or drafting scale, note pad and compass.

Brief Student: Draw a sketch of a flight line plan from an airport directory or a local airport. Discuss how you would go about a survey.

Evaluation

<u>Performance measures</u>	<u>Results</u>
1. Make a usable sketch?	P F
2. Explain some of the points to look for during the survey?	P F

Trainee must receive a pass on all performance measures to qualify in this task. If the individual fails any measure, show what was done wrong and how to do it correctly.

Survey Airport For Hazards and Emergency Equipment

CONDITIONS

You are a new/old member on a mission, and are asked to be a Flight Line Supervisor.

OBJECTIVES

- 1. Understand what to look for when doing a survey.
- 2. Remember to write them down as you find them, with a specific location.

TRAINING AND EVALUATION

Training Outline

- 1. Note any hazards when you do your survey.
 - a. Broken pavement on taxiways or parking ramp.
 - b. Damaged tie down anchors, Missing ropes or chains.
 - c. Loose objects that could cause FOD.
 - d. How the level of hardstand and grass along side match up.
 - e. Housekeeping in hangers, vehicles and other aircraft is essential to personnel safety.
- 2. Note where the emergency equipment is located.
 - a. Fire extinguishers
 - b. First aid supplies
 - c. Telephone with outside line access.

Additional Information

More detailed information on this topic is available in the Flight Line Reference Text.

Evaluation Preparation

Setup: Have pencil and paper.

Brief Student: Make a survey of a local airport, making notes of the hazards and emergency equipment locations.

Evaluation

<u>Performance measures</u>	<u>Results</u>
1. Discuss hazards and how to minimize their effect?	P F
2. Discuss if the emergency equipment is usable and accessible?	P F

Trainee must receive a pass on all performance measures to qualify in this task. If the individual fails any measure, show what was done wrong and how to do it correctly.

O-3110

Supervise Flight Line Marshallsers

CONDITIONS

You are a new/old member on a mission, and are asked to be a Flight Line Supervisor.

OBJECTIVES

- 1. Understand the marshallsers must know the taxi routes, where the refueling, parking, and run-up areas are located.
- 2. Understand where all of the flight line personnel are located and their status.

TRAINING AND EVALUATION

Training Outline

- 1. To perform their job effectively they must understand most of the flight line organization.
 - a. The taxi routes into and out of the ramp area.
 - b. Location of the parking, refueling, and run-up areas.
 - c. Admin procedures for the aircrew.
- 2. You must verify that they know the correct marshalling signals.
 - a. The pilot's signals to them.
 - b. Their signals to the pilots.
 - c. Check their safety equipment.
- 3. Maintain a status board or sheet on all of the flight line personnel.
 - a. Assignment, time, next assignment, time.
 - b. Schedule breaks, lunch and rotate tasks, if possible.
 - c. Check on them periodically.
 - d. Put an experienced person with the trainees.

Additional Information

More detailed information on this topic is available in the Flight Line Reference Text.

Evaluation Preparation

Setup: None.

Brief Student: Explain the procedures used to supervise the marshallsers.

Evaluation

<u>Performance measures</u>	<u>Results</u>
1. Discuss methods to keep track of your personnel?	P F
2. Discuss checking on the well being of the flight line personnel?	P F

Trainee must receive a pass on all performance measures to qualify in this task. If the individual fails any measure, show what was done wrong and how to do it correctly.

Brief Flight Line Marshaller's and Trainees

CONDITIONS

You are a new/old member on a mission, and are asked to be a Flight Line Supervisor.

OBJECTIVES

- 1. Understand what the training status of the flight line personnel are and utilize them accordingly.
- 2. To have all of them understand how the operation is going to function.

TRAINING AND EVALUATION

Training Outline

- 1. Have all flight line personnel been adequately briefed so that they can effectively and safely complete their assigned tasks?
 - a. Do all of them understand their job?
 - b. Are experienced people with the trainees?
 - c. Use a sketch of the airport to show the taxi routes and ramp layout.
- 2. Make sure the communication plan; rest breaks, and other admin functions are covered.
 - a. Do all of them know their post and function?
 - b. Do they know when to do a communication check?
 - c. Do they know where the rest of the mission operation areas are?
 - d. Do they know your location and where to check in and check out of the flight line?
- 3. The better the understanding they have the smooth the operation will run.

Additional Information

More detailed information on this topic is available in the Flight Line Reference Text.

Evaluation Preparation

Setup: Have pencil and paper, mission scenario.

Brief Student: Explain what information is needed in the pre-ops briefing.

Evaluation

<u>Performance measures</u>	<u>Results</u>	
1. Described the job functions?	P	F
2. Described the procedures?	P	F

Trainee must receive a pass on all performance measures to qualify in this task. If the individual fails any measure, show what was done wrong and how to do it correctly.

Tow and Park Aircraft

CONDITIONS

You are a new/old member on a mission, and are asked to be a Flight Line Supervisor.

OBJECTIVES

1. Know how to plan to tow an aircraft.
2. Know how to tow an aircraft.
3. Know how to park an aircraft.

TRAINING AND EVALUATION

Training Outline

1. If you have a full service FBO, you may not have a choice on how aircraft are moved around on the flight line or in hangars. If you do not have a full service FBO, towing will be one of the primary duties. First you need to plan the move.
 - a. Determine the best (shortest and safest) route for your towing operation.
 - b. Be sure there's adequate space at your destination, before moving the aircraft.
 - c. Be sure that the propeller will not be in the way of the tow bar during aircraft movement. If, necessary, carefully move the propeller (opposite normal powered rotation). Always keep your body out of the propeller arc and never wrap your fingers over the blade. The blade can kick back and cause serious injuries.
2. Next prepare the aircraft for towing.
 - a. Select the proper tow bar and attach it to the appropriate location on the nose gear.
 - b. Visually check the nose gear for any turning limit markers and manually check the turn limits for the nose gear by moving the nose gear from side to side. Each aircraft has its own nose wheel turn limit. The "turn limit" is the maximum turning angle of the nose gear. **Typically, the "turn limit" is less than 45 degrees to each side.**
 - c. Perform a thorough walk-around of the aircraft. Start at the left side of the nose (pilots left) and work your way around the entire aircraft. If possible, look inside to confirm that the parking brake is off. If the brakes are "on", do not precede any further, stop and check with the pilot. Do not board an aircraft without the permission from the flight crew.
 - d. Finish the walk-around with a check of the right side of the aircraft. Remove the tie downs and chocks. As you approach the nose of the aircraft, double check the tow bar one last time to ensue that it is securely attached to the aircraft.
3. The next thing to do is the towing process.
 - a. Smoothly begin to move the aircraft, it should move easily.
 - b. Once in motion you should keep your eyes moving at all times. Watch the direction in which you are heading, continually checking the wing clearances, and occasionally checking the nose gear.
 - c. Keep your mind on what you are doing at all times. If someone or something should distract you, stop movement of the aircraft.
 - d. During wet or icy conditions, adjust your speed to maintain margin of safety. Always slow your speed as ramp and visibility conditions deteriorate. Stay within the nose wheel turn limit, avoid sharp turns or sudden movements.
 - e. When pulling the aircraft into position, slowly and smoothly bring the aircraft to a stop so that you do not put any unnecessary stress on the nose gear mechanism. A sudden stop can cause damage to the nose gear.
 - f. Once in place, position the chocks to secure the aircraft. Never remove the tow bar if the aircraft has not been chocked. After chocking always disconnect the tow bar from the aircraft. Return the tow bar to its proper place.
4. The following are important considerations during the towing operation.
 - a. CAP aircraft are to be moved manually, CAP personnel are not authorized to use aircraft towing vehicles.
 - b. Personnel will never cross tow bar while towing is in progress.
 - c. Personnel will never ride on the exterior of the aircraft at anytime during towing.
 - d. Chocks will be immediately available during towing in case of emergency.
 - e. Personnel should never place themselves in the direct path of aircraft wheels while aircraft is moving.
 - f. Personnel will always walk in the direction of the towing (never walk backwards).
 - g. Towing of aircraft is to be only conducted by use of a tow bar.
 - h. NEVER push or pull an aircraft using the propeller.

Additional Information

More detailed information on this topic is available in the Flight Line Reference Text.

Evaluation Preparation

Setup: Parked aircraft, Tow bar, Chocks, and two other marshallers.

Brief Student: Demonstrate how to tow and park an aircraft.

Evaluation

Performance measures

1. Demonstrate how to plan a move.
2. Demonstrate how to tow an aircraft
3. Demonstrate how to park an aircraft

Results

P	F
P	F
P	F

Trainee must receive a pass on all performance measures to qualify in this task. If the individual fails any measure, show what was done wrong and how to do it correctly.

Refuel An Aircraft

CONDITIONS

You are a new/old member on a mission, and are asked to be a Flight Line Supervisor.

OBJECTIVES

- 1. Understand how to safely refuel a CAP aircraft.
- 2. Understand how to document the transaction.

TRAINING AND EVALUATION

Training Outline

- 1. As a Flight Line Marshaller you may be in the position to refuel CAP aircraft. Several situations can present themselves in this case. The Flight Line Supervisor will meet with the Fixed Base Operator (FBO) to determine if CAP Flight Line personnel will accomplish the refueling or if the FBO employees will do the job. For the purposes of this discussion refueling includes checking if the aircraft requires oil.
 - a. Different refueling situations may present themselves, refueling may be accomplished from a fuel truck, from a fuel island, or from both. The Flight Line Supervisor will brief you on how refueling will be accomplished and provide you a checklist.
 - b. Some pilots, particularly those, who are flying their own aircraft, may wish to accomplish the refueling themselves and add their own oil.
 - c. The refueling exercise requires a close attention to safety requirements as well as preventing damage to the aircraft.
- 2. Once the refueling procedure has been established, there are important questions that must be answered each time a CAP aircraft returns from a sortie. Use the radio to find out if the aircraft require fuel? If required, direct the aircraft toward the refueling area. If fuel is not needed and the aircraft can be directed to the parking area.
 - a. If fueling is to be done, after the aircraft is completely shut down, ask the pilot if the aircraft is to be "topped off," what octane fuel is required if you do not know for sure. Ask the pilot is oil is needed and if you are to put it in the engine or the pilot wants to take it with them. Be sure you know how many tanks the aircraft has and how many are to be filled and to what level.
 - b. Ensure the aircraft is properly chocked and grounded before any other action takes place.
 - c. Check to see if the required octane is listed beside the fuel cap and it matches what is being put in the tank.
 - d. Use a mat around the tank inlet to prevent scratches to the paint.
 - e. Do not overfill.
 - f. If you are instructed to add oil, ensure you have the correct weight of oil as specified by the pilot. Use the best spout to prevent spilling the oil, and wipe up any spillage.

Additional Information

More detailed information on this topic is available in the Flight Line Reference Text.

Evaluation Preparation

Setup: Insure all refueling equipment and proper checklist is in position.

Brief Student: Review checklist and equipment with your team to insure each knows what is expected. Assign each task required to a team member.

Evaluation

<u>Performance measures</u>	<u>Results</u>
1. Demonstrate the proper way to refuel and aircraft.	P F
2. Demonstrate the proper way to document the refueling	P F

Trainee must receive a pass on all performance measures to qualify in this task. If the individual fails any measure, show what was done wrong and how to do it correctly.

Keep Track of Aircraft Refueling

CONDITIONS

You are a new/old member on a mission, and are asked to be a Flight Line Supervisor.

OBJECTIVES

1. Understand the importance of keeping legible accurate records of the amount of fuel and oil used.
2. Know why you must keep the director of finance aware of the fuel cost of the mission, periodically.

TRAINING AND EVALUATION

Training Outline

1. A key part of your job and the culmination of each refueling operation is the completion of the documentation or paperwork of the delivery.
 - a. There must be legible and accurate record of the amount of fuel and oil (POL) delivered.
 - b. You must verify that the services ordered by the pilot were the services performed.
2. The fuel meter is the sole method by which you will be able to identify the amount of fuel that is dispensed into the aircraft, and is the means by which you will be able to document the transaction.
 - a. Make sure the meter is reset before each transaction.
 - b. Make sure that the aircraft tail no., no. of gallons of fuel, quarts of oil used and mission flying time are recorded.
 - c. Turn in the records to the director of finance as often as they're needed.

Additional Information

More detailed information on this topic is available in the Flight Line Reference Text.

Evaluation Preparation

Setup: Parked aircraft, note pad and pencil.

Brief Student: After refueling the aircraft, record the data.

Evaluation

<u>Performance measures</u>	<u>Results</u>
1. Demonstrate the ability to keep track of aircraft refueling.	P F
2. Demonstrate the ability to properly recorded all data and report to the Admin/Finance Section Chief	P F

Trainee must receive a pass on all performance measures to qualify in this task. If the individual fails any measure, show what was done wrong and how to do it correctly.

O-3115

Discuss Helicopter Operations

CONDITIONS

You are a new/old member on a mission, and are asked to be a Flight Line Supervisor.

OBJECTIVES

- 1. Become familiar with helicopter operations and know how to use if needed.

TRAINING AND EVALUATION

Training Outline

- 1. CAP does not own helicopters, but some of our partners do. The Flight Line Supervisor should use **Attachment 2** as a reference when needed. This attachment is designed to provide our supervisors procedures to use around helicopters.

Additional Information

More detailed information on this topic is available in the Flight Line Reference Text.

Evaluation Preparation

Setup: None.

Brief Student: Explain the hazards

Evaluation

<u>Performance measures</u>	<u>Results</u>
1. Discuss helicopter operations?	P F
2. Discuss differences from fixed wing and precautions to be used?	P F

Trainee must receive a pass on all performance measures to qualify in this task. If the individual fails any measure, show what was done wrong and how to do it correctly.

P-0101
KEEP A LOG

CONDITIONS

You have been assigned to keep a log on a mission, and must log the actions of your unit, section or team on the ICS Form 214 for use during debrief after the mission.

OJECTIVES

Correctly maintain a log of actions during an incident.

TRAINING AND EVALUATION

Training Outline

1. When working an incident, staff members are required to maintain a log of all significant actions. This is important for record keeping of the accomplishments and setbacks, determining search effectiveness during debriefing, and as a legal record of CAP actions amongst many other things.
2. The mission log is started once a unit or section is opened and maintained until personnel are called in and at home safely to the incident commander. A separate log should be maintained for each varying unit or section that is assigned to the incident, and subordinate units at varying levels will normally also keep a log. This log is turned in with the debriefing paperwork and becomes part of the official mission record.
3. The following actions are always recorded in the log:

FOR GROUND OPERATIONS

- a. Departure and return times to mission base.
- b. Routes taken to and from the search area.
- c. Times of entering and leaving search areas.
- d. Any time the search line changes direction.
- e. Times/locations of clue detections or witness interviews.
- f. Time/location of find.
- g. Time/Location of communications checks.
- h. Any event or action related to the team's ability to complete the sortie requirements (natural hazards encountered, injuries to team members, etc.).
- i. Encounters or instructions from local authorities.
- j. Encounters with the media.
- k. Mileage/Flight time at key intersections, when leaving pavement, at other key locations, etc.

l. Time of distress beacon or other emergency signal acquisition.

m. Times distress beacon located and silenced. Also, if available, include the name(s) and organization(s) of person(s) involved in silencing the distress beacon, the manufacturer, serial number, dates of manufacture and battery expiration, vehicle information (type, vehicle registry, description), and the name of the owner.

n. Personnel assignments to and from the team/unit.

Note: This log (ICSF 214) may be kept as an attachment to the CAPF 109

FOR AIRCREW OPERATIONS

a. Briefing details

b. Names of crew members

c. Engine start time

d. Take Off time

e. Communications checks

f. Time beginning assigned grid or route

g. Time departing grid or route

h. Significant weather, turbulence, other

i. Time of landing

j. Time of engine shutdown

k. Crew changes if any

Note: this log (ICSF 214) may be kept as an attachment to the CAPF 104

FOR MISSION BASE STAFF OPERATIONS

a. Time/date unit or log started or activated

b. Name of unit, supervisor, and individual keeping the log

c. Notes from initial briefing

d. Time and noted from staff meetings

e. Significant events, actions taken, direction received or provided

4. For each log entry, the log keeper writes down the following on the ICSF 214:

- a. The time.
- b. The event taking place (see list above)
- c. Mileage and/or location as appropriate.
- d. Name of individual annotating the log each time there is a change.

Additional Information

More detailed information on this topic is available in each emergency services reference text.

Evaluation Preparation

Setup: Prepare narrative of 10 events/actions and times. Provide the individual with the list, a pen, and an ICS Form 214.

Brief Student: Tell the student that he is the log keeper for his unit, and that the 10 events listed in the narrative have occurred. Tell him to log the events/actions on the on team log form.

Note: this evaluation can be accomplished during a training exercise by observing the events taking place and checking the log to see that they are properly annotated.

Evaluation

Performance measures

Results

For each of the 10 events/actions, the student:

- | | | |
|----------------------------------|---|---|
| 1. Logs the time and event | P | F |
| 2. Writes legibly and completely | P | F |

Student must receive a pass on all performance measures to qualify in this task. If the individual fails any measure, show what was done wrong and how to do it correctly.

P-2001
DISCUSS MISSION PILOT DUTIES AND RESPONSIBILITIES

CONDITIONS

You are a Mission Pilot trainee and must discuss MP duties and responsibilities.

OBJECTIVES

Discuss Mission Pilot duties and responsibilities.

TRAINING AND EVALUATION

Training Outline

1. As a Mission Pilot trainee, knowing your duties and responsibilities is essential.
2. The first and foremost duty of a mission pilot is to fly the aircraft in a safe and proficient manner, following all applicable FAA and CAP rules and regulations. All other duties are secondary to those of the aircraft commander.
3. The second most important duty of a mission pilot is to remember that he or she is the *pilot* -- *not* a scanner. You are the Pilot-in-Command (PIC) and you must never forget that.
4. In addition to the normal duties of a PIC, CAP mission pilots must also perform all the non-scanner duties of the Observer if no qualified observer is on board.
5. In addition to PIC duties, your general duties and responsibilities include:
 - a. Obtain complete briefings and plan the sortie. A good mission pilot always includes the observer during these activities. [Remember, you may be the aircraft commander but you are not always the mission commander; an experienced observer should serve as mission commander whenever possible.]
 - b. Thoroughly brief the crew before the flight (include fuel management).
 - c. Thoroughly brief the crew on their responsibilities during all phases of the flight.
 - d. Obtain a flight release.
 - e. Enforce sterile cockpit rules.
 - f. Fly search patterns as completely and precisely as possible. Report any deviations from the prescribed patterns during debriefing.
 - g. Monitor the observer and ensure all events, sightings and reports are recorded and reported.
 - h. Fill out all forms accurately, completely and legibly.
6. The Mission Pilot needs to know what goes into the observer's log, in order to help inexperienced observers and to be able to keep the log when riding in the right seat. The log is maintained from take-off until landing, and should include all events and sightings. It is important to log the geographical location of the search aircraft at the time of all events and sightings (as a habit, always log the Hobbs time each time you make a report or record an event or sighting). This information is the basis of CAP Form 104, which is passed back to the incident commander and general staff after the debriefing and becomes a part of the total information that is the basis for his subsequent actions and reports. Good logs give the staff a better picture of how the mission is progressing. If sketches or maps are made to compliment a sighting, note this and attach them to the log. The log and all maps and sketches will be attached to the CAPF 104.

Additional Information

More detailed information on this topic is available in CAPR 60-1 and in Chapter 12 and Attachment 2 of the Mission Aircrew Reference Text (MART).

Evaluation Preparation

Setup: Provide the student with a current copy of CAPR 60-1 and the MART.

Brief Student: You are a Mission Pilot trainee asked about your duties and responsibilities, and to discuss the Observer Log.

Evaluation

Performance measures

Results

- | | | |
|---|---|---|
| 1. State the first and foremost duty of the mission pilot. | P | F |
| 2. State the second-most important duty of the mission pilot. | P | F |
| 3. Discuss general duties and responsibilities. | P | F |
| 4. Discuss the information recorded in the Observer Log. | P | F |

Student must receive a pass on all performance measures to qualify in this task. If the individual fails any measure, show what was done wrong and how to do it correctly.

DISCUSS GENERAL CAP-RELATED SAFETY REQUIREMENTS AND ISSUES

CONDITIONS

You are a Mission Pilot trainee and must discuss general CAP-related safety requirements and issues.

OBJECTIVES

Discuss general CAP-related safety requirements and issues.

TRAINING AND EVALUATION

Training Outline

1. As a Mission Pilot trainee, knowing general CAP-related safety requirements and issues is essential.
2. *Flying into and taxiing on unfamiliar airports.* CAP missions often require flying into small, non-towered and unlighted airports. The mission pilot needs to quickly obtain information about these airfields. Of particular importance:
 - a. Runways. Determine length, width, markings and lighting. Is runway alignment compatible with predicted wind direction and strength? If not, what is your alternative?
 - b. Taxiways. Are there any, or will you have to back taxi? Are the taxiways marked and/or lighted?
 - c. If you will be arriving in low visibility conditions or at night, taxi SLOWLY and use a wing walker if necessary. If you can't see the turnoff to the taxiway or the taxiway itself -- STOP.
 - d. Obstacles. Note all near the airport and its approaches.
 - e. Services. Fuel and oil, phone, tie downs, and maintenance. Will they be open when you arrive? Is there a phone number to call after normal hours? If in doubt, call ahead -- most FBOs are glad to assist CAP.
 - f. Local NOTAMS.
3. *Flying into large, busy airports.* Of particular importance:
 - a. Airspace and obstacles. Review airspace layout and restrictions, and note all relevant frequencies (including ATIS, AWOS or ASOS).
 - b. Taxiways. Make sure you have a taxiway diagram, and review it before you land. Brief the crew so they can assist you.
 - c. Local NOTAMS.
4. *Taxiing around and near a large number of aircraft:*
 - a. Follow the taxi plan that is in the Operations Plan, if applicable.
 - b. Taxi no faster than a slow walk when around obstacles.
 - c. When there are no flight line personnel or marshalls available, do not taxi within ten feet of any obstacle; stop, and then proceed at no faster than a slow walk.
 - d. Follow all signals given by flight line personnel. However, use common sense as some of the flight line marshals may have little or no experience. If it looks too close -- STOP.
 - e. Pilot aids such as the *Airport/Facility Directory* or commercial products such as the *Flight Guide* (Airguide Publications, Inc.) are invaluable tools for the CAP mission pilot. One should be carried in the aircraft at all times, and kept *current*. Also, several web sites (e.g., AOPA) have very detailed airport layouts available for downloading.
 - f. Another often-overlooked safety measure is reconnoitering the terrain around unfamiliar airports to determine your actions in the event the engine quits on takeoff. Get in the habit of flying a circuit around the airport upon arrival to look for emergency landing areas off the ends of each runway. Ask local pilots

for the best actions to take if you lose an engine on takeoff (from each runway). Also, suggest that mission staff include this information in the general briefing, if necessary.

5. *Squawks*. CAP aircraft have Discrepancy Logs - use them! While private pilots may delay 'minor' repairs, mission pilots should not. Just as ELT missions always seem to occur between midnight and 0dark30, you can bet that a nighttime mission will come up if a landing, taxi, strobe or navigation light is out. Been having troubles with your comm radios? Get ready for an ELT search in Class B airspace.

CAP pilots often fly unfamiliar aircraft during missions. Pay particular attention to each aircraft's squawk sheet, and don't fly unless you are satisfied with the aircraft's condition: question the aircraft's regular crew about the particulars of their aircraft -- probe for "unwritten" squawks.

In a related matter, keeping the aircraft windows clean and having a well-stocked cleaning kit in the aircraft is vital. How many of you have arrived at the airport for a night flight and found that the last pilot had flown through a bug convention and neglected to clean the windscreen? And, as if this isn't enough of a delay in launching the mission, you can't find anything to clean the windscreen!

6. *Fuel management*. CAP missions often require flying long distances to mission bases, and the missions themselves involve flying several sorties a day. Mission aircrews often carry a lot of luggage and equipment. Missions are flown in widely varying weather conditions. Therefore mission pilots must carefully plan, check and manage their fuel.

- a. Per CAPR 60-1, the PIC is responsible for maintaining a sufficient fuel supply to ensure landing with one hour of fuel remaining (computed at normal POH/AFM cruise fuel consumption). If it becomes evident the aircraft will not have that amount of fuel at its intended destination, the PIC will divert the aircraft to an airport that will ensure the requirement is met.
- b. Weight & Balance computations *must* be accurate. Do you include the weight of the permanent equipment stowed in the aircraft? Do you change your W&B from the standard FAA 170 pounds when a crewmember that doesn't meet the Air Force weight standards shows up? Do you have a scale available at your headquarters to weigh luggage and equipment?
- c. If you do not fill the aircraft fuel tanks to the top or a tab, do you have a means to accurately determine fuel on board? Each aircraft that is routinely filled to a level less than full should have a calibrated fuel-measuring device on board. Remember that these devices are specific to the particular aircraft!
- d. *Each CAP aircraft should have information concerning the aircraft's fuel consumption rate for various power settings, taken from actual flight conditions*. If the information is not in the aircraft, ask the aircraft's regular pilot for fuel burn rates. If neither of these options is available, be very conservative in your planning. Long cross-country flights, or a series of legs in a flight, or a series of mission sorties require careful planning. Make sure you note your assumptions (e.g., distance, power setting, and predicted wind direction and speed) so that you can compare them against actual conditions in flight.
- e. *Brief your crew, especially the observer, on these assumptions so they can assist you in managing the fuel*. The pilot or observer should ask about fuel status at least once an hour, or before departing on each leg or sortie. Are the winds as predicted, or are you facing a stronger-than-expected headwind? Is your power set at economy cruise, as you planned, or have you gone to full power because you're running late? Did the last leg take as long as you had planned, or did ATC put you in the north forty for 30 minutes for "traffic separation"?

If in doubt, *land and refuel!* Just in case, *land and refuel!*

7. *Unfamiliar aircraft equipment*. CAP aircraft are not equipped uniformly. If you are assigned to another aircraft than the one you usually fly, check the equipment. If you don't know how to use its GPS, tell air operations. If you can't set up and operate the GPS, you won't be able to use it correctly. If you try to learn "on the fly," you will spend too much time with your head inside the aircraft instead of looking outside. The same

reasoning applies to the Audio Panel, FM radio, and DF unit. In these cases, someone will probably be available to show you how to set up and operate the equipment.

Even something as simple as an unfamiliar navaid can affect safety. In most cases, just spending some time sitting in the aircraft and going over an unfamiliar comm radio or transponder will suffice. But if you've never used an HSI before, this isn't the time to learn.

Whatever you do, don't try to bluff your way through. Tell someone and ask for assistance. Another pilot can help you, or mission staff may assign another pilot or experienced observer to your crew who knows how to operate the equipment.

8. *Trainees and inexperienced crewmembers.* CAP aircrew members may be trainees, or simply inexperienced. You must take the time to ascertain the qualifications and experience level of any crewmember assigned to you.

If a crewmember is a trainee, spend extra time on briefings and be very specific as to duties and responsibilities. If the trainee is a scanner, listen in on the observer's briefing to make sure he does the same. Make sure trainees understand that, while you will teach them as much and as often as possible, you (and the observer) have duties that must not be interfered with.

If a crewmember is newly qualified or has not flown in some time, make allowances. You may have to assume some of their normal duties (e.g., setting up and operating nav aids or radios) in certain situations, so be sure to brief them so there is no confusion. For example, you may brief that you will handle all ATC communications while in Class C airspace while the inexperienced observer will handle all other communications.

Cadets and some seniors often qualify as flight line marshalls as their first mission specialty, and there is no practical way to determine their experience level. On some missions the flight line is handled by whoever is available, regardless of qualifications. Be alert and brief your aircrew to be alert. Don't hesitate to stop the aircraft if a marshaller's signals don't make sense or seem to be leading you into an unsafe situation.

9. *Low and slow.* CAP mission search patterns often require you to fly below 1000 AGL and at speeds at or below 90 knots (but never below V_x). Proficiency and planning are critical.

- a. Ensure that "low and slow" is an integral part of your proficiency program.
- b. Strictly enforce sterile cockpit rules under these conditions, and make sure your crew is briefed on all obstacles in the search area.
- c. Flying at low altitude often means losing radar and communications with ATC and mission base. Don't hesitate to climb back up to an altitude where you can make your "ops normal" reports.
- d. Maintain situational awareness and continually ask yourself, "If the engine quits now, where will I land?"
- e. CAPR 60-1 requires pilots to maintain a minimum of 500 feet above the ground, water, or any obstruction and a minimum of 2000' AGL at night (except for takeoff/landing or when under ATC control). For SAR/DR/CD/HLS reconnaissance, the pilot will maintain at least 800 AGL. Pilots may descend below the designated search altitude to attempt to positively identify the target (but never below 500 AGL); once the target has been identified the pilot will return to 800' AGL or higher. [Refer to CAPR 60-1 for special restrictions for over-water missions.]
- f. Per CAPR 60-1, minimum airspeed will be no lower than the aircraft's published best rate of climb speed (except for takeoff, landing, go-arounds, practice stalls, slow flight training and evaluation, and glider towing).
- g. Per CAPR 60-1, practice of in-flight emergency procedures and maneuvers will be conducted during daylight VMC at an altitude high enough to allow recovery from an inadvertent stall/spin entry and complete a recovery at no lower than 2000' AGL or the aircraft manufacturer, FAA, or CAP approved training syllabi recommended altitude, whichever is higher. Simulated forced landings will be discontinued prior to descending below 500' AGL, unless you intend to land.

Additional Information

More detailed information on this topic is available in CAPR 60-1 and in Chapter 12 of the Mission Aircrew Reference Text (MART).

Evaluation Preparation

Setup: Provide the student with a current copy of CAPR 60-1 and the MART.

Brief Student: You are a Mission Pilot trainee asked about general CAP-related safety requirements and issues.

Evaluation

<u>Performance measures</u>	<u>Results</u>	
1. Concerning general CAP-related safety requirements and issues, discuss:		
a. Flying into and taxiing on unfamiliar airports.	P	F
b. Flying into large, busy airports.	P	F
c. Flying into large, busy airports.	P	F
d. Taxiing around and near a large number of aircraft.	P	F
e. Taxiing around and near a large number of aircraft.	P	F
f. Squawks.	P	F
g. Fuel management.	P	F
h. Unfamiliar aircraft equipment.	P	F
i. Trainees and inexperienced crewmembers.	P	F
j. Low and slow.	P	F

Student must receive a pass on all performance measures to qualify in this task. If the individual fails any measure, show what was done wrong and how to do it correctly.

DISCUSS TYPES OF FLIGHTS PERFORMED BY CAP AIRCREWS

CONDITIONS

You are a Mission Pilot trainee and must discuss the types of flights performed by CAP aircrews.

OBJECTIVES

Discuss the types of flights performed by CAP aircrews.

TRAINING AND EVALUATION

Training Outline

1. As a Mission Pilot trainee, knowing the types of flights that CAP aircrews perform is essential. CAPR 60-1 covers the types of flights for CAP aircraft, but we want to look at a few of these in a little more detail.

Note that per CAPR 60-1, the minimum flight visibility for VFR flight in Class G airspace is three statute miles (unless the PIC is instrument current), and you must update altimeter settings hourly from the closest source.

2. *Transportation flights.* Always consult CAPR 60-1, Chapter 2 (Authorized Passengers) when you need to know who is authorized to fly as passengers in CAP aircraft and the conditions under which they are authorized to fly.

As a general rule, anyone other than CAP or US government employees need special permission to fly in CAP aircraft. All non-CAP members eligible to fly aboard CAP aircraft must execute a CAPF 9, *Release (for non-CAP Members)*, prior to the flight.

3. *Night flights.* Typical sorties flown at night are transport sorties, route searches, and DF searches (it seems these are always flown at late at night). CAPR 60-1 requires pilots to maintain a minimum of 2000' AGL at night (except for takeoff/landing or when under ATC control). During night over-water missions, both front-seat crewmembers must be CAP qualified mission pilots and both will be instrument qualified and current (the right-seat pilot need not be qualified in the specific aircraft).

As a minimum, the PIC should be night-current in the aircraft (category, class and type) you're going to fly and assure the required one-hour fuel reserve required by CAPR 60-1. When performing night searches it is preferable to have an experienced crew accompanying the pilot to assist in situational awareness and search procedures.

Night time route searches will only be successful if the downed aircraft or missing person has the capability to signal the aircraft or if an ELT has been activated. Usually, ground team searches near the LKP or intended airport stand a better chance of success. No CAP crewmember may use night vision devices during any flight operations.

The most important item when planning night sorties is the PIC. Flying at night requires more attention to preflight planning and preparation. In particular, a careful check of the weather is essential; probably the most significant problem that can occur at night is flying into weather you cannot see. Also, pay attention to the dew point spread as a predictor of fog. During the flight, maintain situational awareness and always know where you can land in an emergency.

Before you accept the mission, ask yourself a few questions:

- a. If all the night flying you have had in the last 90 days are your three takeoffs and landings, are you really proficient?
- b. How long has it been since you've done a night cross-country?
- c. How long has it been since you've done a night ELT search?
- d. If you are Instrument rated, how many approaches have you done at night lately?
- e. How familiar are you with the terrain and obstacles along the route?
- f. Since landing lights only fail at night, when was the last time you practiced landing without the landing light?
- g. Have you included all your flashlights in the weight-and-balance?

Remember that confidence is gained by experience, so you should include night flying in your proficiency regimen. You should also include periodic DF training at night.

4. *IMC flights.* CAP sorties are very seldom flown in IMC. The most common reason for an IFR flight is to transport personnel to a search area or mission base. However, it is possible to conduct a route search in IMC. If an aircraft was lost while on an IFR flight plan, a sortie may be launched along the same route with the hope of picking up an ELT signal. This approach may also be taken, with careful planning and close coordination with ATC, for aircraft lost outside prescribed IFR routes.

It is also possible to DF in IMC, but this can be dangerous and is not to be undertaken lightly. Per CAPR 60-1, IFR flights will not depart unless the weather is at or above landing minimums at the departure airport.

In any case, a few extra precautions are in order:

- a. The pilot must have completed section XIV, "Instrument Proficiency" on her Form 5.
- b. The PIC must meet FAA instrument flight proficiency requirements.
- c. The PIC should be proficient in instrument flight in the CAP aircraft to be used.
- d. For any flight other than a simple IFR transportation flight, it is highly recommended that another current and proficient Instrument-rated pilot be in the right seat. *Never* fly a search alone in IMC.
- e. Never fly an instrument search when ground teams are appropriate and available for the search.

5. *Video Imaging.* More and more, we are performing aerial reconnaissance for our partner agencies. We primarily take still photos (digital and 35mm) and video (analog and digital), and may use Slow Scan video. The mission pilot must know how to fly these missions. As SAR missions decline and the phase-out of 121.5 MHz ELTs begins, video imaging will become one of CAP's most valuable assets.

Emergency response planners expect more timely information about developing situations. These planners recognize real-time and near real-time images as an invaluable tool.

Regardless of the type of video imaging mission, there are some basics that everyone involved in the mission need to know to ensure success. The following presents the extra essentials needed for a video mission briefing:

- a. Make sure each crewmember knows what the target is and what types of images are needed. For example, a sortie may require a digital still shot of the target area for orientation, followed by a recorded video to detail egress points.
- b. Ensure the target location is identified so that you can find it.
- c. Thoroughly brief the route to and from the target, and the flight patterns within the target area. Mark them on the appropriate sectional chart and maps (e.g., road or topographical).
- d. Ensure minimum altitudes are established, both for the routes to and from the target and in the target area.
- e. Ensure all communications frequencies are well understood. This is particularly important for Slow Scan sorties.

- f. Define the duties of the PIC and the photographer when in the target area. The photographer will actually be in command of the mission and will give directions to the pilot, but the PIC retains responsibility for the safe operation of the aircraft.
- g. Ensure video equipment batteries are fully charged and that extra batteries are available.
- h. Clean the aircraft windows. If the video will be shot from the front right seat (normal), remove the window latch screw and put it in a safe place.
- i. For Slow Scan sorties, make sure the equipment is secured and properly connected. Make a test transmission before you leave the ramp.

The customer sometimes defines *video imaging flight profiles*, but a typical profile is shown and discussed below:

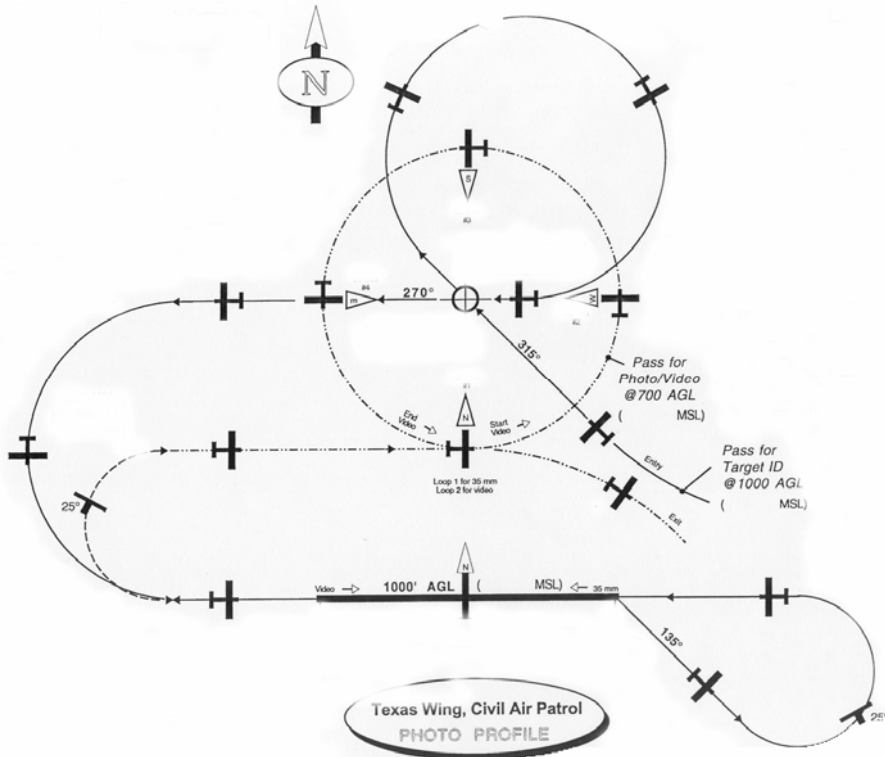

As the aircraft approaches the target the photographer should alert the pilot and prepare to begin photographing the target. You may need to over-fly the target first for positive identification. Assume the photographer is in the right front seat.

The first step is to take an identification photo, usually one mile south of the target from an altitude of 1000' AGL. The photographer will begin shooting as soon as the aircraft is established on this easterly route. If another pass is needed, the pilot will circle around to repeat the route.

Next the pilot will turn toward the target, descend to 500' AGL and establish a 1/2 nm circuit around the target. The photographer will be taking shots at the cardinal points of the circle, or continuously if using video. This circuit may be enlarged to fit the target area or if it is important to identify entrance and egress routes near the disaster area.

During slow-scan sorties it may be necessary to climb to a higher altitude to transmit each image.

NOTE: Never hesitate to make another pass or move to a better position if necessary to ensure the success of the sortie. Film (especially digital) is cheap and flight time is expensive; it is better to make another pass or reposition the aircraft at the scene than it is to send another aircraft back to repeat the mission.

6. *Proficiency.* CAPR 60-1 encourages pilots to maintain currency and proficiency by accomplishing a self-conducted proficiency flight at least once every 90 days (described in an Attachment, and using mission symbol C1). More specifically, mission pilots are authorized four hours of proficiency flight training per calendar month under Air Force-assigned non-reimbursed mission status (described in an Attachment, and using mission symbol B12).

When practicing in-flight emergencies, adhere to the restrictions in CAPR 60-1.

As the demands on the CAP mission pilot increase, the need to maintain and improve your mission skills becomes more important. Besides the guidance given in the CAPR 60-1 Attachments, you should also practice:

- a. Search patterns. Use the GPS as your primary tool but also practice planning and flying the different patterns using VORs and pilotage.
- b. Night proficiency. Practice search patterns at night (particularly the ELT search).

As part of your cross-country proficiency, practice with the GPS:

- a. Maintain a constant track over ground.
- b. Select/display a destination: Airport, VOR and User Waypoint.
- c. Determine heading, time and distance to a waypoint.
- d. Save lat/long coordinates as a User Waypoint.
- e. Save your present position as a User Waypoint.
- f. Enter and use flight plans.
- g. Exercise the nearest airport and nearest VOR features.
- h. Practice navigating with present position displayed (constant lat/long display).
- i. Always try to take someone along with you on your proficiency flights. This will provide excellent practice for scanners and observers, helps improve CRM and teamwork, and makes the flights more enjoyable. [Remember, if you are going to be practicing instrument approaches you must use a safety pilot. It is also preferred to have one during your night practice, although a qualified non-pilot observer will serve just as well.]

Additional Information

More detailed information on this topic is available in CAPR 60-1 and in Chapter 12 of the Mission Aircrew Reference Text (MART).

Evaluation Preparation

Setup: Provide the student with a current copy of CAPR 60-1 and the MART.

Brief Student: You are a Mission Pilot trainee asked about the types of CAP flights.

Evaluation

Performance measures

Results

1. Concerning types of CAP flights, discuss:

- | | | |
|---|---|---|
| a. Transportation. | P | F |
| b. Night. | P | F |
| c. IMC. | P | F |
| d. Video imaging, including the typical flight profile. | P | F |
| e. Proficiency. | P | F |

Student must receive a pass on all performance measures to qualify in this task. If the individual fails any measure, show what was done wrong and how to do it correctly.

P-2004
DISCUSS SECURITY CONCERNS AND PROCEDURES

CONDITIONS

You are a Mission Pilot trainee and must discuss security concerns and restrictions, and describe your actions in case of an airborne interception.

OBJECTIVES

Discuss security concerns and restrictions, and describe your actions in case of an airborne interception.

TRAINING AND EVALUATION

Training Outline

1. As a Mission Pilot trainee, knowing security concerns and restrictions is essential. Additionally, you must know how to respond to an airborne interception.
2. *Security.* CAP resources should be considered National Security assets. In times of emergency you should take special security precautions to protect the aircraft and crew. Some examples are:
 - a. Hanger the aircraft whenever possible. You may place small pieces of clear tape on fuel caps, the cowling and/or doors that will break if someone tampers with vital areas.
 - b. Pay particular attention during pre-flight inspections. Look for signs of tampering and carefully inspect the fuel for contamination.
 - c. Be as "low key" as possible, and be discrete. Don't discuss CAP business in public places.
 - d. Be aware of your surroundings at all times. If you see something or someone that is suspicious, don't ignore it. Report your suspicions to your supervisor and/or law enforcement.
3. *Airspace restrictions.* The FAA may issue Temporary Flight Restrictions at any time, so it is vitally important to ask for FDC NOTAMs before each flight and to monitor ATC for changes while in flight. TFRs were issued to establish enhanced Class B airspace, protect airspace around nuclear facilities, and protect airspace around large gatherings of people.

Even with most TSRs lifted, you should not loiter around or circle critical facilities (e.g., nuclear power plants, large stadiums or gatherings, air shows, and dams or reservoirs). If you have to circle critical facilities (e.g., for planning or actual mission purposes) make sure you coordinate with the facility's manager and ATC.

4. *In-flight Intercept.* If your aircraft accidentally approaches or encroaches restricted airspace military aircraft may intercept you; it is important to know how to respond. The following covers the important points; details can be found in AIM 5-6-2.

An intercept to identify your aircraft has three phases:

- a. Approach phase. A flight leader and wingman will coordinate their individual positions in conjunction with the ground-controlling agency.
- b. Identification phase. The intercepted aircraft should expect to visually acquire the lead interceptor and possibly the wingman during this phase. The wingman will assume a surveillance position while the flight leader approaches your aircraft. The flight leader will then initiate a gentle closure toward the your aircraft, stopping at a distance no closer than absolutely necessary to obtain the information needed. The interceptor aircraft will use every possible precaution to avoid startling you.
- c. Post-intercept phase. After you have been identified, the flight leader will turn away. The wingman will remain well clear and rejoin the leader.

If you are intercepted you should immediately:

- a. Follow the instructions given by the intercepting aircraft, interpreting and responding to the visual signals (see the Table below).
- b. Notify ATC if possible.
- c. Attempt to communicate with the intercepting aircraft and/or ATC on the emergency frequency 121.5 MHz, giving the identity and position of your aircraft and the nature of the flight.
- d. If equipped with a transponder, squawk 7700 unless otherwise instructed by ATC. If any instructions received by radio from any sources conflict with those given by the intercepting aircraft by visual or radio signals, request clarification while continuing to comply with the instructions given by the intercepting aircraft.

Intercepting aircraft signal	Meaning	Intercepted aircraft response	Meaning
Rocks wings. After acknowledgement initiates a slow level turn, normally to the left, onto desired heading.	You have been intercepted. Follow me.	Rocks wings and follows.	I understand and will comply.
<i>(At night, the pilot will also flash the navigational lights at irregular intervals.)</i>		<i>(At night, the pilot will also flash the navigational lights at irregular intervals.)</i>	
Performs an abrupt breakaway maneuver consisting of a climbing 90° turn without crossing the intercepted aircraft's flight path.	You may proceed.	Rocks wings.	I understand and will comply.
Circle airport, lowers landing gear, and over-flies runway in the direction of landing.	Land at this airport.	Lowers landing gear, follows the intercepting aircraft and lands if the runway is considered safe.	I understand and will comply.
<i>(At night, the pilot will also put the landing lights on.)</i>		<i>(At night, the pilot will also put the landing lights on.)</i>	
Raises landing gear while flying over runway between 1,000' and 2,000', and continues to circle the airport.	This airport is inadequate.	If the intercepted aircraft is requested to go to an alternate airport, the intercepting aircraft raises its landing gear and uses the intercept procedures (listed above).	Understood, follow me.
<i>(At night, the pilot of the intercepted aircraft will also flash landing lights while passing over the runway.)</i>		To release the intercepted aircraft, the intercepting aircraft will perform the breakaway maneuver listed above.	Understood, you may proceed.

The pilot switches on and off all available lights at regular intervals.	Cannot comply.	Performs the breakaway maneuver listed above.	Understood.
The pilot switches on and off all available lights at irregular intervals.	In distress.	Performs the breakaway maneuver listed above.	Understood.

Additional Information

More detailed information on this topic is available in CAPR 60-1 and in Chapter 12 of the Mission Aircrew Reference Text (MART).

Evaluation Preparation

Setup: Provide the student with a current copy of CAPR 60-1 and the MART.

Brief Student: You are a Mission Pilot trainee asked security concerns and restrictions, and your actions if intercepted.

Evaluation

Performance measures

Results

- | | | |
|---|---|---|
| 1. Discuss security concerns. | P | F |
| 2. Discuss airspace restrictions. | P | F |
| 3. Describe the phases of an in-flight intercept, and your actions. | P | F |

Student must receive a pass on all performance measures to qualify in this task. If the individual fails any measure, show what was done wrong and how to do it correctly.

DISCUSS MISSION PILOT RESPONSIBILITIES DURING A MISSION

CONDITIONS

You are a Mission Pilot trainee and must discuss the mission pilot's responsibilities during a mission.

OBJECTIVES

Discuss the mission pilot's responsibilities during a mission.

TRAINING AND EVALUATION

Training Outline

1. As a Mission Pilot trainee, knowing the mission pilot's responsibilities during the mission is essential.
2. *Mission Pilot and POD.* There are some factors affecting Probability of Detection (POD) that you can control:
 - a. Ask questions during briefings to ensure you *really* understand your assignment.
 - b. Take the time to plan the flight thoroughly and make sure you are prepared to fly it before leaving mission base. This knowledge enables you to concentrate on the mission and "stay ahead of the aircraft," thus increasing search effectiveness.
 - c. Maintain optimum altitude and airspeed. If you have to decrease power on a southbound leg and increase power when you turn northbound in order to maintain a constant 90 knots, then do it.
 - d. Accuracy of navigation: Use the GPS! However, you should be ready to complete the search using other navigational methods should the GPS fail.
 - e. Avoid turbulence whenever possible, avoid steep or abrupt turns, and ensure the mission commander is scheduling breaks and monitoring the scanners (and yourself) for fatigue or dehydration.
 - f. Give a thorough debriefing and be brutally honest about your effectiveness.
 - g. Stay proficient in your flying skills. Flying the aircraft and operating its equipment should be second nature, leaving you free to concentrate on accomplishing mission objectives safely.
3. *Flying the Mission.* Before missions are launched, the briefing officer provides you with information designating the routes to and from the search area, and the types of search patterns to be used upon entering the search area. Your planning should involve the observer, as they are familiar with each type of search pattern and can assist you in planning and navigation. While the observer should be scanning while you fly the pattern, they can assist you if things become confused (hey, it can happen).
4. *Number of Scanners.* Search planning, probability of detection, and search pattern effectiveness depends upon some underlying assumptions; the most important as far as the aircrew is concerned is the *assumption that there is one crewmember dedicated to scanning out the right side of the aircraft and another on the left side.*

Since the majority of CAP aircraft are Cessna 172s that only carry three crewmembers, we will assume that the crew consists of a pilot, an observer in the right front seat, and a single scanner in the rear seat. We assume that the observer will be scanning out the right side of the aircraft while the scanner covers the left side. If a larger aircraft is used there may be two scanners in the rear seat; this will allow the observer to spend more time assisting you without seriously decreasing search effectiveness.

Mission pilots must remember that they are *not* scanners. A mission pilot who tries to fly the aircraft and scan the search area at the same time is doing neither job effectively or safely. The mission pilot is responsible

for placing the scanners' eyes over the search area so they can do their job; your job is to fly the pattern precisely and effectively and for ensuring the safety of the aircraft.

Single scanner

- a. Planning and executing a search pattern with only one scanner on board is different from one where you have two scanners. You will only be able to search out one side (usually the right side) of the aircraft; this means that you must keep the right side of the aircraft towards the search area at all times. This can have a significant effect on search time and aircraft hours. For example, this would require careful planning and flying on a grid search since you will have to modify your leg entries/tracks to ensure the scanner scans the entire grid (no inverted flight, please).
 - b. Additionally, this cannot help but decrease search effectiveness due to fact that you lose the "double coverage" or overlap you get with two scanners looking out opposite sides of the aircraft. Scanner fatigue also becomes more of a factor, and search times need to be reduced to account for this.
 - c. For these reasons, performing parallel track or creeping line searches with a single scanner is not recommended. Likewise, searching any but open/flat terrain with a single scanner significantly reduces your chances of success.
5. *Flying a search pattern.* The mission pilot's contribution to a successful search is his ability to fly the search pattern precisely while maintaining altitude and airspeed. This must be done while performing the duties of a Pilot-in-Command; in the search area the most important of these duties is to "see and avoid" obstacles and other aircraft.

Another special consideration in flying search patterns is the possibility of engine trouble or failure at low altitude. The mission pilot must always be aware of where she is, the wind direction, the nature of the terrain, and where she will land if the engine fails *now*. This also underscores the importance of a thorough pre-flight inspection.

Like the rest of the aircrew, the mission pilot must continuously and honestly critique her performance during the sortie. If you're not set up properly when you enter the search area, exit and start again. If you are off by half a mile on a leg, fly the leg again. If winds and/or turbulence caused you to fly the legs erratically, emphasize this during the debriefing.

6. *Go or No-Go.* The Incident Commander has authorized your flight, you have obtained a proper briefing and flight release, you have filed your flight plan, you have completed a thorough pre-flight of the aircraft, and your crew is briefed and ready to go. *A Mission Pilot may accomplish all of this and still not be safe to fly the mission.*

How can this be? All of the regulations and safety precautions have been followed to the letter. You have been extensively trained and have demonstrated proficiency by successfully completing a Form 91 checkride. Your wing commander has appointed you as a CAP Mission Pilot!

It all comes down to the individual pilot and the circumstances. How long has it been since you've taken off in a 14-knot crosswind? Have you ever taken off or landed on an icy runway? When is the last time you've flown cross-country at night? You're signed off for instrument privileges on your Form 5, but how long has it been since you've flown in actual IMC?

Pilots, by their nature, are confident in their abilities. Sometimes over-confident. Mix in overconfidence, unusual circumstances, and the need to put all those hours of training to the test. Now add the desire to help others who are in immediate danger and you have all the ingredients for a dangerous situation.

The most effective way to break this potential accident chain is for Mission Pilots to be brutally honest about their abilities under the present conditions. Mission Pilots (as Pilot-in-Command) must have enough courage and integrity to decline a mission that they don't feel *comfortable* doing.

Additional Information

More detailed information on this topic is available in CAPR 60-1 and in Chapter 12 of the Mission Aircrew Reference Text (MART).

Evaluation Preparation

Setup: Provide the student with a current copy of CAPR 60-1 and the MART.

Brief Student: You are a Mission Pilot trainee asked your responsibilities during a mission.

Evaluation

<u>Performance measures</u>	<u>Results</u>
1. Discuss your responsibilities during a mission:	
a. How you can improve POD.	P F
b. Flying the mission.	P F
c. Number of scanners onboard.	P F
d. Flying a search pattern.	P F
e. Go or No-Go decisions.	P F

Student must receive a pass on all performance measures to qualify in this task. If the individual fails any measure, show what was done wrong and how to do it correctly.

DISCUSS MISSION OBSERVER DUTIES AND RESPONSIBILITIES

CONDITIONS

You are a Mission Observer trainee and must discuss observer duties and responsibilities.

OBJECTIVES

Discuss Observer duties and responsibilities.

TRAINING AND EVALUATION

Training Outline

1. As a Mission Observer trainee, understanding your duties and responsibilities is essential. The mission observer has a key role in CAP missions, and has expanded duties that mainly pertain to assisting the mission pilot. This assistance may be in the planning phase, handling radio communications, assisting in navigation, and crew management (i.e., mission commander). The proficient observer makes it possible for the pilot to perform his duties with a greater degree of accuracy and safety by assuming these aspects of the workload.
2. The Observer's primary role while actually in a search area is that of scanner.
3. General duties and responsibilities include:
 - a. Depending on conditions, you may report with the mission pilot for briefing. Wear appropriate clothes for a mission.
 - b. Assist in planning the mission. The observer may act as mission commander for the sortie.
 - c. Assist in avoiding collisions and obstacles during taxiing.
 - d. Assist in setting up and operating aircraft and CAP radios.
 - e. Assist in setting up and operating aircraft navigational equipment (e.g., VORs and GPS).
 - f. Assist enforcing the sterile cockpit rules.
 - g. Maintain situational awareness at all times.
 - h. Assist in monitoring fuel status.
 - i. Monitor the electronic search devices aboard the aircraft and advise the pilot when making course corrections in response to ELT signals.
 - j. Keep mission base and/or high bird appraised of status.
 - k. Coordinate scanner assignments and ensure proper breaks for the scanners (including yourself). Monitor crew for fatigue and dehydration (ensure the crew drinks plenty of fluids).
 - l. Maintain a chronological flight log of all observations of note, including precise locations, sketches and any other noteworthy information.
 - m. Depending on conditions, report with the mission pilot for debriefing immediately upon return to mission base. The applicable portions on the reverse of CAPF 104 should be completed prior to debrief.
 - n. Keep track of assigned supplies and equipment.
4. Once team members have been briefed on the mission and accomplished the necessary planning, observers determine that all necessary equipment is aboard the airplane. Checklists help ensure that all essential equipment is included, and vary according to geographic location, climate, and terrain of the search area. Items on the observer's checklist should include CAP membership and specialty qualification cards, current charts and maps of the search area, flashlights, notebook and pencils, binoculars, and survival gear (prohibited items, such as firearms, should be listed too, to ensure none is included). A camera may be included to assist in describing the location and condition of the search objective or survivors. Unnecessary items or personal belongings

should be left behind. The mission observer also assists the pilot in ensuring that all equipment aboard the search aircraft is properly stowed. An unsecured item can injure the crew or damage the aircraft in turbulence.

5. Once airborne, the observer provides navigation and communication assistance, allowing the pilot to precisely fly the aircraft with a greater degree of safety. The observer also assists in enforcing "sterile cockpit" rules when necessary. In flight, particularly the transit phase, the observer maintains situational awareness in order to help ensure crew safety.
6. The mission observer divides and assigns scanning responsibilities during her mission observer briefing, and ensures each scanner performs their assigned duty during flight. She monitors the duration of scanner activity, and enables the scanners to rest in order to minimize fatigue.
7. Observer Log. The observer must become proficient in using an in-flight navigational log. A complete chronological log should be maintained from take-off until landing, and should include all events and sightings. Skill in maintaining the log requires training and experience. Remember, *proficiency and confidence are gained through practice and application*. It is important to log the geographical location of the search aircraft at the time of all events and sightings (as a habit, always log the Hobbs time each time you make a report or record an event or sighting). This information is the basis of CAP Form 104, which is passed back to the incident commander and general staff after the debriefing and becomes a part of the total information that is the basis for his subsequent actions and reports. Good logs give the staff a better picture of how the mission is progressing. If sketches or maps are made to compliment a sighting, note this and attach them to the log. The log and all maps and sketches will be attached to the CAPF 104.

Additional Information

More detailed information on this topic is available in CAPR 60-1 and in Chapter 1 of the Mission Aircrew Reference Text (MART).

Evaluation Preparation

Setup: Provide the student with a current copy of CAPR 60-1 and the MART.

Brief Student: You are an Observer trainee asked about your duties and responsibilities, and to discuss the Observer's job and log.

Evaluation

<u>Performance measures</u>	<u>Results</u>
1. State the primary role of the observer, particularly when in the search area.	P F
2. Discuss general duties and responsibilities.	P F
3. Discuss pre-flight duties and responsibilities.	P F
4. Discuss in-flight duties and responsibilities.	P F
5. Discuss post-flight duties and responsibilities.	P F
6. Discuss what should be entered into the observer log.	P F

Student must receive a pass on all performance measures to qualify in this task. If the individual fails any measure, show what was done wrong and how to do it correctly.

P-2008
DISCUSS THE DANGERS OF ICING

CONDITIONS

You are a Mission Observer trainee and must discuss how icing occurs and associated dangers.

OBJECTIVES

Discuss how airframe and carburetor icing occur and their affects on aircraft performance.

TRAINING AND EVALUATION

Training Outline

1. As a Mission Observer trainee, knowing how icing forms and affects the aircraft is essential.
2. *Frost.* When the ground cools at night, the temperature of the air immediately adjacent to the ground is frequently lowered to the saturation point, causing condensation. This condensation takes place directly upon objects on the ground as dew if the temperature is above freezing, or as frost if the temperature is below freezing. Dew is of no importance to aircraft, but frost can be deadly. Normally we think of frost as unimportant - it forms on cars or other cold surfaces overnight, soon melting after the sun rises. However, frost on an airplane disturbs the airflow enough to reduce the lift and efficiency of aerodynamic surfaces. An airplane *may* be able to fly with frost on its wings, but, even with the airflow over the wings only slightly disrupted, controllability can become unpredictable. *Frost should always be removed before flight.* Some precautions should be taken if frost is expected, such as placing the aircraft in a hanger (even a T-hanger).
3. *Airframe icing.* There are only two fundamental requisites for ice formation on an aircraft in flight: first the aircraft must be flying through visible water in the form of rain or cloud droplet, and second, when the liquid water droplets strike, their temperature or the temperature of the airfoil surface, must be 32° F. or below. Ice increases drag and decreases lift: an ice deposit of as little as one-half inch on the leading edge of a wing can reduce lift by about 50%, increase drag by an equal percentage, and thus greatly increase the stall speed. Ice deposits also increase weight (on a typical C172 a quarter-inch coating of ice can add up to 150 lbs., a half-inch can add 300 lbs., and an inch of clear ice can add 600 lbs.). Additionally, propeller efficiency is decreased.

Sorties should never be flown in regions of possible icing. As altitude increases, temperature decreases at a fairly uniform rate of 2° Celsius or 3.6° Fahrenheit for each 1000 feet. This rate of temperature change is known as the *lapse rate*. At some altitude, the air temperature reaches the freezing temperature of water, and that altitude is known as the *freezing level*. You can estimate the freezing level prior to flight by using simple mathematics. For example, if the airport elevation is 1,000 feet and the temperature at ground level is 12° Celsius, the freezing level would be at approximately 6,000 feet above ground level (AGL) or 7,000 feet above mean sea level (MSL). Since the lapse rate is 2° per thousand feet, it would take 6,000 feet of altitude to go from 12° Celsius to 0°, the freezing temperature of water. The same technique works for Fahrenheit, but you use 3.6° for the lapse rate. Don't forget to include the airport elevation in your computations -- altimeters are normally set to display MSL rather than AGL altitude. [This method yields a very approximate value for the freezing level. You are encouraged to leave a wide margin for error above and below this altitude if you must fly through visible moisture during a search.]

4. *Carburetor icing.* Unlike aircraft structural icing, carburetor ice can form on a warm day in moist air. In the winter when temperatures are below 40° F. the air is usually too cold to contain enough moisture for carburetor ice to form. In the summer when temperatures are above 85° F. there is too much heat for ice to form. So, airplanes are most vulnerable to carburetor icing when operated in high humidity or visible moisture with

temperatures between 45° and 85° F. It's most likely to become a problem when the aircraft is operated at low power settings, such as in descents and approaches to landings.

5. Taxiing in snow and ice can be dangerous. The pilot should never attempt to taxi through snow banks, and should be very deliberate and careful while taxiing on snow or ice. Run-ups should be conducted in an area free of snow or ice, if possible. The observer (and scanner) must assist the pilot in these conditions, and be especially watchful for runway and taxiway boundaries and other obstacles that may be obscured by snow or ice.

Additional Information

More detailed information on this topic is available in Chapter 6 of the MART.

Evaluation Preparation

Setup: None.

Brief Student: You are an Observer trainee asked to discuss icing.

Evaluation

Performance measures

Results

1. Discuss the following concerning icing:

- | | | |
|---|---|---|
| a. Freezing level. | P | F |
| b. How airframe frost and icing affects aircraft performance. | P | F |
| c. How carburetor icing affects aircraft performance. | P | F |

Student must receive a pass on all performance measures to qualify in this task. If the individual fails any measure, show what was done wrong and how to do it correctly.

DISCUSS THE DANGERS OF REDUCED VISIBILITY CONDITIONS

CONDITIONS

You are a Mission Observer trainee and must discuss the causes and dangers of reduced visibility.

OBJECTIVES

Discuss the causes and dangers of reduced visibility and their effect on search operations.

TRAINING AND EVALUATION

Training Outline

1. As a Mission Observer trainee, basic knowledge of how reduced visibility conditions affect search operations.
2. Reduced visibility conditions. One of the most common hazardous weather problems is loss of visibility. This can happen either suddenly or very insidiously, depriving the pilot of his ability to see and avoid other aircraft, and reducing or depriving him altogether of his ability to control the aircraft, unless he has had training and is proficient in instrument flying. In reduced visibility, the crew's ability to see rising terrain and to avoid towers, power transmission lines, and other man-made obstacles is diminished. Visibility may be reduced by many conditions including clouds, rain, snow, fog, haze, smoke, blowing dust, sand, and snow. A similar condition called "white out" can occur where there has been snowfall.

Fog, especially dense fog, can make it extremely difficult, if not impossible, to see landing runways or areas. The crew should be alert for a potential problem with fog whenever the air is relatively still, the temperature and dew point are within several degrees, and the temperature is expected to drop further, as around sunset and shortly after sunrise. This is often a factor in delaying the first sorties of the day.

Haze, a fine, smoke-like dust causes lack of transparency in the air. It's most often caused when still air prevents normal atmospheric mixing, allowing the particles to persist, instead of the wind's dispersing them. Like fog, it is most likely to occur when the air is still. When haze and smoke are present, the best measure a flight crew can take to minimize risk of such an encounter is to get a thorough weather briefing before flying, and update the briefing by radio with *Flight Watch* as required.

3. Effects. According to FAA regulations, under almost all circumstances flight using visual flight rules can only be conducted with at least three miles of visibility. If clouds cover more than one-half the sky, the cloud bases must be no lower than 1,000 feet above the terrain. In addition, search aircraft must usually remain at least 500 feet below the cloud deck.

Each member of the aircrew must be vigilant during all phases of the flight when visibility is less than perfect. Crew resource management requires that each member of the crew be assigned an area to search during the takeoff, transit and approach-to-landing phases of the flight in order to help the pilot "see and avoid" obstacles and other aircraft. The aircrew must also characterize visibility in the search area so as to establish the proper scanning range: search visibility may be different than expected, and your search pattern may have to be adjusted accordingly. Be sure to cover this during your debriefing.

Additional Information

More detailed information on this topic is available in Chapter 6 of the MART and Attachment 2 of the MART.

Evaluation Preparation

Setup: None.

Brief Student: You are an Observer trainee asked to discuss reduced visibility conditions and their affect on search operations.

Evaluation

<u>Performance measures</u>	<u>Results</u>
1. Discuss the following concerning reduced visibility conditions:	
a. Reduced visibility conditions.	P F
b. Basic reduced visibility minimums.	P F
c. Effects on search operations.	P F

Student must receive a pass on all performance measures to qualify in this task. If the individual fails any measure, show what was done wrong and how to do it correctly.

P-2010
DISCUSS THE DANGERS OF WIND AND THUNDERSTORMS

CONDITIONS

You are a Mission Observer trainee and must discuss effects and dangers of wind and thunderstorms.

OBJECTIVES

Discuss effects and dangers of wind and thunderstorms.

TRAINING AND EVALUATION

Training Outline

1. As a Mission Observer trainee, knowing the effects and dangers of winds and thunderstorms is essential.
2. Winds around pressure systems. Certain wind patterns can be associated with areas of high and low pressure: air flows from an area of high pressure to an area of low pressure. In the Northern Hemisphere during this flow the air is deflected to the right because of the rotation of the earth. Therefore, as the air leaves the high-pressure area, it is deflected to produce a clockwise circulation. As the air flows toward a low-pressure area, it is deflected to produce a counterclockwise flow around the low-pressure area.

Another important aspect is air moving out of a high-pressure area depletes the quantity of air. Therefore, highs are areas of descending air. Descending air favors dissipation of cloudiness; hence the association that high pressure usually portends good weather. By similar reasoning, when air converges into a low-pressure area, it cannot go outward against the pressure gradient, nor can it go downward into the ground; it must go upward. Rising air is conducive to cloudiness and precipitation; thus the general association low pressure — bad weather.

3. Convection currents. Certain kinds of surfaces are more effective than others at heating the air directly above them. Plowed ground, sand, rocks, and barren land give off a great deal of heat, whereas water and vegetation tend to absorb and retain heat. The uneven heating of the air causes small local circulation called “convection currents”, which are similar to the general circulation just described. Convection currents cause the bumpiness experienced by aircrews flying at low altitudes in warmer weather. On a low flight over varying surfaces, the crew will encounter updrafts over pavement or barren places and down drafts over vegetation or water. Ordinarily this can be avoided by flight at higher altitudes, so aircrews may need to climb periodically to take a break from the rough air at search altitudes.

Convection currents also cause difficulty in making landings, since they affect the rate of descent. The figures below show what happens to an aircraft on a landing approach over two different terrain types. The pilot must constantly correct for these affects during the final approach to the airport.

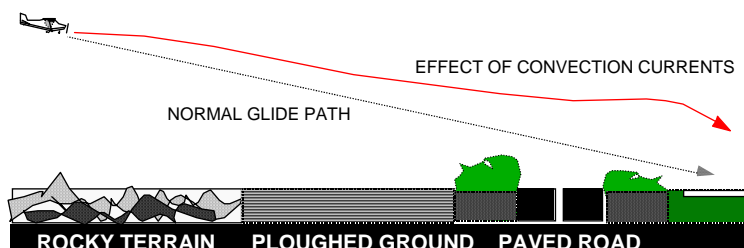

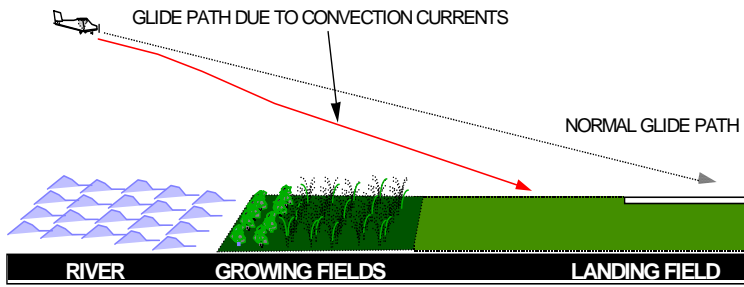

4. Cold and warm fronts. Certain characteristics of frontal activities will affect search effectiveness (primarily visibility and turbulence). For the aircrew, these factors must be considered during mission planning.

Characteristics of a cold, unstable air mass are:

- Cumulus and cumulonimbus clouds
- Unlimited ceilings (except during precipitation)
- Excellent visibility (except during precipitation)
- Unstable air resulting in pronounced turbulence in lower levels (because of convection currents)
- Occasional local thunderstorms or showers - hail sleet, snow flurries

Characteristics of a warm, stable air mass are:

- Stratus and stratocumulus clouds
- Generally low ceilings
- Poor visibility (fog, haze, smoke, and dust held in lower levels)
- Smooth, stable air with little or no turbulence
- Slow steady precipitation or drizzle

5. Windshear. Windshear is best described as a change in wind direction and/or speed within a very short distance in the atmosphere. Under certain conditions, the atmosphere is capable of producing some dramatic shears very close to the ground; for example, wind direction changes of 180° and speed changes of 50 knots or more within 200 ft. of the ground have been observed. This, however, is unusual. Turbulence may or may not exist in wind shear conditions. If the surface wind under the front is strong and gusty there will be some turbulence associated with wind shear.

6. Thunderstorms. A thunderstorm is any storm accompanied by thunder and lighting. It usually includes some form of precipitation, and can cause trouble for aircraft in many forms: turbulence, icing, poor visibility, hail, wind shear, microbursts, lightning, and, in severe cases, tornadoes. No thunderstorm should ever be taken lightly. During the cumulus stage, vertical growth occurs so quickly that climbing over the developing thunderstorm is not possible. Flight beneath a thunderstorm, especially in the mature stage, is considered very foolish, due to the violent down drafts and turbulence beneath them. Flight around them may be a possibility, but can still be dangerous. Even though the aircraft may be in clear air, it may encounter hail, lightning, or turbulence a significant distance from the storm's core. *Thunderstorms should be avoided by at least 20 miles laterally.* The safest alternative, when confronted by thunderstorms, is to land, tie the aircraft down, and wait for the storms to dissipate or move on.

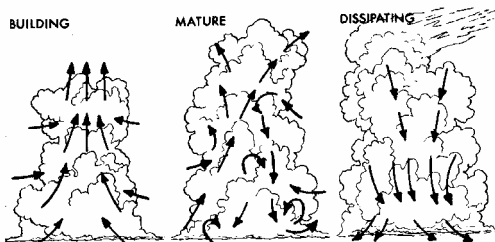

Additional Information

More detailed information on this topic is available in Chapter 6 of the MART.

Evaluation Preparation

Setup: None.

Brief Student: You are an Observer trainee asked to discuss the dangers of winds and thunderstorms.

Evaluation

<u>Performance measures</u>	<u>Results</u>
1. Discuss the effects of convection currents, particularly during landing.	P F
2. Discuss wind patterns around high- and low-pressure areas.	P F
3. Discuss the characteristics of cold and warm fronts.	P F
4. Discuss the dangers of windshear.	P F
5. Discuss the dangers of thunderstorms.	P F

Student must receive a pass on all performance measures to qualify in this task. If the individual fails any measure, show what was done wrong and how to do it correctly.

DISCUSS THE EFFECTS OF DENSITY ALTITUDE ON AIRCRAFT PERFORMANCE

CONDITIONS

You are a Mission Observer trainee and must discuss how density altitude affects aircraft performance.

OBJECTIVES

Describe the factors that are used to determine density altitude, and discuss the effect of high density altitude on aircraft performance and strategies to deal with high density altitudes during search operations.

TRAINING AND EVALUATION

Training Outline

1. As a Mission Observer trainee, knowing how density altitude affects aircraft performance is very helpful.
2. *Atmospheric pressure.* Pressure at a given point is a measure of the weight of the column of air above that point. As altitude increases, pressure diminishes as the weight of the air column decreases. This decrease in pressure has a pronounced effect on flight. The aircraft's altimeter is sensitive to these changes in pressure, and displays this pressure as altitude. When the altimeter is set to the current reported altimeter setting it indicates the aircraft's height above mean sea level (MSL). [If a local altimeter setting is unavailable, pilots usually set the altimeter to indicate the airport's MSL elevation.]



Changes in pressure are registered in inches of mercury: the *standard* sea-level pressure is 29.92 inches at a *standard* temperature of 15° C (59° F). If CAP aircraft always operated at standard conditions, the altimeter would always be accurate. An aircraft with an indicated (on the altimeter) altitude of 5,000' MSL will really be 5000' above the ground (AGL). However, these standard conditions rarely exist because the density of the atmosphere is always changing as altitude and temperature changes. [The third factor - humidity - also effects density, but the effect is smaller and its very hard to determine.]

3. *Pressure altitude.* Pressure altitude is an altitude measured from the point at which an atmospheric pressure of 29.92 inches of mercury is found. A good rule of thumb is that a 1,000' change of altitude results in a 1-inch (mercury) change on a barometer. Another way to determine pressure altitude is to enter 29.92 into the altimeter's window and read the resulting altitude indication.
4. *Density altitude.* When pressure altitude is corrected for non-standard temperature, *density altitude* can be determined.

5. *Effects.* The combined effects of high altitude and temperature (high density altitude) can have a significant effect on performance of aircraft engines, wings, propellers, and the pilot and crew. If all missions were conducted on cool, low humidity days along the Gulf coast there would be no concern with air density and its implications on flight safety. Obviously, this isn't the case. In fact, these conditions have often been primary factors in aircraft accidents, and may result in loss of the search aircraft, unless you pay careful attention.

The most noticeable effect of a decrease in pressure (increase in density altitude) due to an altitude increase becomes evident during takeoff, climb, and landing. An airplane that requires a 1,000' run for takeoff at a sea-level airport will require a run almost twice as long at an airport that is approximately 5,000' above sea level. The purpose of the takeoff run is to gain enough speed to generate lift from the passage of air over the wings. If the air is thin, more speed is required to obtain enough lift for takeoff- hence, a longer ground run. It is also true that the engine is less efficient in thin air, and the thrust of the propeller is less effective. The rate of climb is also slower at the higher elevation, requiring a greater distance to gain the altitude to clear any obstructions. In landing, the difference is not so noticeable except that the plane has greater groundspeed when it touches the ground.

6. *Strategies.* The mission staff can make a number of decisions to help minimize the effects of high density altitude operations and thus maximize flight safety. If aircraft having turbo-charged or super-charged engines are available, the incident commander may assign their crews that part of the search over the high terrain. Supercharging or turbocharging regains some of the engine performance lost with the decrease in air density, but cannot improve upon that lost from the wings or propeller.

Incident commanders may schedule flights to avoid searching areas of high elevation during the hottest times of the day. This is a tradeoff though, in that the best sun angles for good visibility often coincide with the hot times of the day. The incident commander may also elect to limit crew size to minimize airplane total weight. Instead of dispatching a four-seat aircraft with a pilot, observer, and two scanners aboard, he may elect to send a pilot, observer and single scanner only. Again, this represents a tradeoff, where some search capability is sacrificed for a higher margin of safety.

The pilot may decide to takeoff on a mission with only the fuel required for that mission and the required reserve, rather than departing with full fuel tanks. Each crewmember can help by leaving all *nonessential* equipment or personal possessions behind. In areas of high density altitude, airplane performance can be improved significantly by simply leaving nonessential, excess weight behind.

To help remember these conditions and their effects, an observer should remember the four "H's." *Higher Humidity, Heat, or Height all result in reduced aircraft performance.* Available engine power is reduced, climb capability is reduced, and takeoff and landing distances are increased.

7. *Mountainous terrain.* Aircrews flying the mountains must complete a course such as *Mountain Fury*.

When flying in mountainous areas it is recommended that flights be planned for early morning or late afternoon because heavy turbulence is often encountered in the afternoon, especially during summer. In addition, flying at the coolest part of the day reduces density altitude. Attempt to fly with as little weight as possible, but don't sacrifice fuel; in the event of adverse weather, the additional reserve could be a lifesaver.

Study sectionals for altitudes required over the route and for obvious checkpoints. Prominent peaks make excellent checkpoints, as do rivers and passes. Be aware that mountain ranges have many peaks that may look the same to the untrained eye, so continually crosscheck your position with other landmarks and radio aids if possible. Also, the minimum altitude at which many radio aids are usable will be higher in the mountains. For that reason, low-frequency navigation, such as ADF, LORAN, or GPS tend to work best in the mountains.

A weather check is essential for mountain flying. Ask specifically about winds aloft even when the weather is good. Expect winds above 10,000 feet to be prevailing westerlies in the mountain states. If winds aloft at your proposed altitude are above 30 knots, do not fly. Winds will be of much greater velocity in passes, and it will be more turbulent as well. Do not fly closer than necessary to terrain such as cliffs or rugged areas. Dangerous turbulence may be expected, especially when there are high winds (see figures, below).

Crews must be constantly careful that a search never takes them over terrain that rises faster than the airplane can climb. Narrow valleys or canyons that have rising floors must be avoided, unless the aircraft can be flown from the end of higher elevation to the lower end, or the pilot is *certain* that the aircraft can climb faster than the terrain rises. Careful chart study by the crew prior to flight will help identify this dangerous terrain.

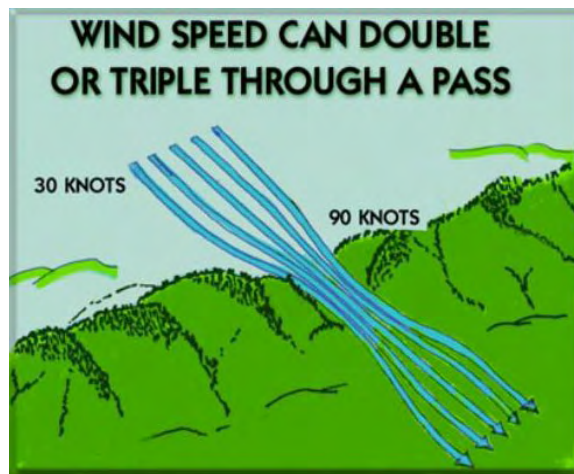
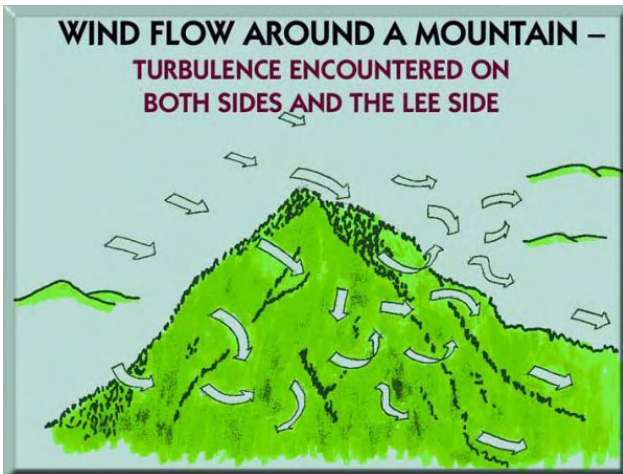

Additional Information

More detailed information on this topic is available in Chapter 7 of the MART.

Evaluation Preparation

Setup: Provide the student with charts and/or a flight computer to compute density altitude.

Brief Student: You are an Observer trainee asked to calculate density altitude and discuss its effects.

Evaluation

<u>Performance measures</u>	<u>Results</u>
1. Discuss atmospheric pressure, pressure altitude and density altitude.	P F
2. Obtain the local altimeter setting and enter it into an aircraft altimeter.	P F
3. Discuss how high density altitude degrades aircraft performance.	P F
4. Discuss strategies to deal with high density altitude on search operations.	P F
5. Discuss mountainous terrain precautions and strategies.	P F

Student must receive a pass on all performance measures to qualify in this task. If the individual fails any measure, show what was done wrong and how to do it correctly.

P-2012
IDENTIFY CONTROLLED AND SPECIAL USE AIRSPACES ON A SECTIONAL
CONDITIONS

You are a Mission Observer trainee and must identify controlled and special use airspaces on a sectional chart.

OBJECTIVES

Identify controlled and special use airspaces on a sectional chart and discuss operations in or near each.

TRAINING AND EVALUATION

Training Outline

1. As a Mission Observer trainee, being able to identify and discuss operations near controlled airports and special use airspaces is essential.
2. Controlled airports. The most stringent requirements normally are associated with flight in airspace immediately surrounding a major airport due to the high density of operations conducted there. Observers must be alert for required communication when it appears a search will be conducted within 40 miles of a major airport or within 5 miles of any airport having an operating control tower: these are color coded *blue* on sectional charts. Major airports in this context are generally near major metropolitan areas and appear at or near the center of concentric blue-, magenta-, or gray-colored circles. Also, crew resource management and the "sterile cockpit" environment are essential in or near these busy airports in order to "see and avoid" obstacles and other aircraft.
3. Special Use Airspace. Although not a class of airspace, the FAA has designated some airspace as "special use" airspace. The FAA has specifically created special use airspace for use by the military, although the FAA retains control. Active special use airspace can become a navigational obstacle to search aircraft and uncontrolled objects (e.g., missiles) within the airspace can present a serious threat to the safety of CAP aircraft and personnel. Special use airspace normally appears on sectional charts as irregularly shaped areas outlined by *either blue or magenta hatched lines*. It is also identified by either a name, such as Tyndall E MOA, or an alphanumerical identifier like R-4404A. Hours of use and vertical limits of special use airspace areas, as well as the FAA facility controlling each area, are printed in one of the margins of the sectional chart. If the CAP crew has any doubt about entering special use airspace, it should contact the appropriate air traffic control facility first to check the status of the area in question.

Prohibited Areas contain airspace within which the flight of aircraft is prohibited for national security or other reasons. An example is the airspace around the White House.

An "R" prefix to a five-letter identifier indicates a *Restricted Area*. The Army may be conducting artillery firing within this airspace, or military aircraft may be practicing actual air-to-surface bombing, gunnery, or munitions testing. Shells, bombs, and bullets, as well as the dirt and fragments they throw into the air on ground impact, present a severe hazard to any aircraft that might come in their path. The restricted area's boundaries are always printed in *blue*.

Within the boundaries of a *Military Operations Area (MOA)* the military may be conducting high-speed jet combat training or practicing air-to-ground weapons attack, without objects actually being released from the aircraft. MOA boundaries and their names are always printed in *magenta* on the sectional chart. Civilian aircraft operating under VFR are *not* prohibited from entering an active MOA, and may do so at any time without any coordination whatsoever (although this is considered foolish by many pilots). As stated earlier,

since the FAA retains control of the airspace, it is prudent to contact the controlling air traffic facility before continuing a search into any MOA. Military aircraft, often flying at very low altitudes and at high speeds, are usually not in radar or radio contact with the air traffic controller (nor can they see or hear you). A controller can only provide positive separation to civilian IFR aircraft from the MOA boundary, *not* from the military aircraft itself. This may force significant maneuvering off your intended course.

4. **Military Training Routes.** Although not classified by the FAA as special use airspace, military training routes (MTRs) are for military low-altitude high-speed training. MTRs are identified by one of two designations, depending upon the flight rules under which the military operates when working within that airspace. *Instrument Routes* (IR) and *Visual Routes* (VR) are identified on sectional aeronautical charts by medium-weight solid gray lines with an alphanumeric designation. 4-digit numbers identify MTRs flown at or below 1500 feet AGL; 3-digit numbers identify those flown above 1500 feet AGL.

Only route centerlines are printed on sectional charts, but each route includes a specified lateral distance to either side of the printed centerline and a specific altitude “block”. Route widths vary, but can be determined for any individual route by requesting Department of Defense *Flight Information Publication AP-1B* at the Flight Service Station.

The letters *IR* (e.g., IR-120) indicate that military aircraft operate in that route according to IFR clearances issued by air traffic control. Other non-military VFR aircraft may enter the lateral or vertical boundaries of an active IR route without prior coordination, while aircraft operating IFR are kept out by air traffic control. Just as in the case of a MOA, air traffic control may not have radar and radio contact with the military aircraft using the route. Therefore, it is necessary to provide separation between other IFR aircraft and the route airspace regardless of where the military aircraft may be located along the route. This may force either a route or altitude change. You can request the status of IR routes from the controlling air traffic facility.

The letters *VR* (e.g., VR-1102) indicate that the military operates under VFR when operating within the lateral and vertical limits of that airspace. The see-and-avoid concept applies to *all* civilian and military aircraft operating there, and all crew members must be vigilant in visual lookout when within or near a VR training route. Many military missions go to and from visual training routes' start and exit points on IFR clearances, and the prudent crew can inquire about the status of the route with air traffic control when operating through or near a VR training route.

You can determine *scheduled* military activity for restricted areas, MOAs, and military training routes by checking *Notices to Airmen* (NOTAMS) at the Flight Service Station. However, checking with the air traffic control facilities is preferable, since it will reveal *actual*, "real time" activity versus *scheduled* activity. When flying through any special use airspace or training route, crewmembers should be alert and cautious at all times, because incorrect or incomplete coordination between the military and the FAA is the rule rather than the exception.

Additional Information

More detailed information on this topic and examples are available in Chapter 8 of the MART.

Evaluation Preparation

Setup: Provide the student a sectional chart(s) containing controlled airports and all forms of special use airspaces.

Brief Student: You are an Observer trainee asked to identify (sectional) and discuss operations near controlled airports and special use airspaces.

Evaluation

Performance measures

Results

1. Identify (sectional) and discuss operations in and near, and identify on a sectional chart:
 - a. Controlled airport. P F
 - b. Prohibited airspace. P F
 - c. Restricted airspace. P F
 - d. Military Operating Area. P F
 - e. Military Training Routes. P F

Student must receive a pass on all performance measures to qualify in this task. If the individual fails any measure, show what was done wrong and how to do it correctly.

P-2013
DISCUSS MISSION SCANNER DUTIES AND RESPONSIBILITIES

CONDITIONS

You are a Mission Scanner trainee and must discuss scanner duties and responsibilities.

OBJECTIVES

Discuss scanner duties and responsibilities.

TRAINING AND EVALUATION

Training Outline

1. As a Mission Scanner trainee, understanding your duties and responsibilities is essential. Additionally, a basic knowledge of the Mission Observer's duties and responsibilities is helpful.
2. The scanner's primary role is performing an effective visual search, maintaining constant eye contact with the ground while flying over the search area.
3. A scanner must report to duty in accordance with the "IM SAFE" criteria of CAPR 60-1. This covers illness, medication, stress, alcohol, fatigue, and emotion.
4. Other duties and responsibilities include:
 - a. Wear appropriate clothes for a mission.
 - b. Carry and properly use equipment. Return borrowed or assigned equipment.
 - c. Carry current credentials.
 - d. Assist in avoiding obstacles during taxiing.
 - e. Obey sterile cockpit rules.
 - f. Report observations accurately and honestly, and report all sightings.
 - g. Keep accurate sketches and notes.
 - h. Properly complete all pertinent paperwork.
 - i. Report availability for additional assignments.
5. Review and discuss observer duties and responsibilities:
 - a. Report with the mission pilot for briefings.
 - b. Assist in planning the mission.
 - c. Assist in avoiding collisions and obstacles during taxiing.
 - d. Assist in setting up and operating aircraft and CAP radios.
 - e. Assist in setting up and operating aircraft navigational equipment.
 - f. Assist enforcing sterile cockpit rules.
 - g. Maintain situational awareness at all times.
 - h. Assist in monitoring fuel status.
 - i. Monitor the electronic search devices aboard the aircraft and advise the pilot when making course corrections in response to ELT signals.
 - j. Keep mission base and/or high bird apprised of status.
 - k. Coordinate scanner assignments and ensure proper breaks for the scanners; monitor the crew for fatigue and dehydration.

- l. Maintain a chronological flight log of all observations of note, including precise locations, sketches and any other noteworthy information.
- m. Report with the mission pilot for debriefing; assist in completing the reverse of CAPF 104.
- n. Keep track of assigned supplies and equipment.

Additional Information

More detailed information on this topic is available in CAPR 60-1 and in Chapter 1 of the Mission Aircrew Reference Text (MART).

Evaluation Preparation

Setup: Provide the student with a current copy of CAPR 60-1 and the MART.

Brief Student: You are a Scanner trainee asked about your duties and responsibilities, and to discuss the Scanner's job.

Evaluation

<u>Performance measures</u>	<u>Results</u>
1. State the primary role of the scanner.	P F
2. Discuss the "IM SAFE" criteria.	P F
3. Discuss other scanner duties and responsibilities.	P F
4. Review the observer duties and responsibilities.	P F

Student must receive a pass on all performance measures to qualify in this task. If the individual fails any measure, show what was done wrong and how to do it correctly.

P-2014
DISCUSS CAP LIABILITY COVERAGE AND MISHAP REPORTING

CONDITIONS

You are a Mission Scanner trainee and must discuss CAP liability coverage and mishap reporting.

OBJECTIVES

Discuss liability coverage provided to CAP personnel and mishap reporting.

TRAINING AND EVALUATION

Training Outline

1. As a mission aircrew member there is a small chance that you may be involved in an accident during a mission. A basic knowledge of liability coverage provided to you, and its applicability and limitations, is essential.
2. Using the current CAPR 900-5 discuss the following, including when the coverage applies and what is covered:
 - a. Federal Employee Compensation Act (FECA).
 - b. Federal Tort Claims Act (FTCA).
 - c. CAP corporate insurance.
3. Using the current CAPR 62-2 and CAPF 78 (Mishap Report Form), discuss what constitutes an accident, when it must be reported, what information is needed, and who it is given to.
4. Using the current CAPR 60-1, discuss assessments that can be made for damage to CAP aircraft.

Additional Information

More detailed information on this topic is available in Chapter 1 of the Mission Aircrew Reference Text (MART).

Evaluation Preparation

Setup: Provide the student with current copies of CAPR 900-5, 62-2 (with a copy of CAPF 78), and 60-1.

Brief Student: You are an aircrew member asked to discuss FECA, FTCA and CAP corporate coverage, reporting requirements in case of an accident, and assessments that may be made for aircraft damage.

Evaluation

<u>Performance measures</u>	<u>Results</u>
1. Discuss FECA, including what types of missions afford this coverage and what is covered.	P F
2. Discuss FTCA, including what types of missions afford this coverage and what is covered.	P F
3. Discuss the various assessments that can be made for damage to CAP aircraft.	P F

3. Discuss CAP corporate insurance, including what types of missions afford this coverage and what is covered. P F
4. Discuss CAP mishap reporting, including what must be reported, how, and to whom. P F

Student must receive a pass on all performance measures to qualify in this task. If the individual fails any measure, show what was done wrong and how to do it correctly.

P-2015
ENTER DATA INTO CAP FORMS

CONDITIONS

You are a Mission Scanner trainee and must enter data into a form.

OBJECTIVES

Accurately and legibly enter data into forms and show how to correct mistakes.

TRAINING AND EVALUATION

Training Outline

1. As a Mission Scanner trainee you must know how to enter data into forms and how to correct mistakes.
2. CAP and our partner agencies rely on accurate and complete paperwork. CAP strives to maintain a professional image, and providing data that is legible is essential to this image.
3. Filling out forms and other paperwork is an essential part of any mission. Time and effort must be given to this part of the mission.
4. Some general rules to follow:
 - a. It is important not to obliterate a mistake (i.e., a person should still be able to read the mistaken entry). To correct mistakes, draw a single line through the error, enter the correct data, and initial.
 - b. Do not use of "liquid paper" when making corrections.
 - c. Do not use signature labels or stamped signatures.
 - d. Attachments (e.g., maps or sketches) should have your name, the date, aircraft 'N' number, mission and sortie numbers, and Hobbs time on them so they can be tied to the CAP form if they become separated.
 - e. Do not leave blanks; enter N/A in the blank.
 - f. Always have another crewmember review the form before submittal.

Additional Information

More detailed information on this topic is available in Chapter 1 of the MART.

Evaluation Preparation

Setup: Provide the student with a current copy of CAPF 104.

Brief Student: You are a Scanner trainee asked general rules for entering data into forms, marking attachments to forms, and correcting mistakes.

Evaluation

<u>Performance measures</u>	<u>Results</u>
1. Show how to correct a mistake.	P F
2. Show how to mark a map that you will attach to a form.	P F

Student must receive a pass on all performance measures to qualify in this task. If the individual fails any measure, show what was done wrong and how to do it correctly.

P-2016
IDENTIFY AND DISCUSS MAJOR AIRCRAFT CONTROLS

CONDITIONS

You are a Mission Scanner trainee and must identify and describe the major aircraft control features.

OBJECTIVES

Identify and discuss major aircraft controls.

TRAINING AND EVALUATION

Training Outline

1. As a Mission Scanner trainee, basic knowledge of how a typical CAP aircraft is controlled is helpful, particularly during emergencies.
2. The basic structure is the fuselage, and all other parts are attached to it. The primary source of lift is the wing, while other parts provide stability and control. The tail (empennage) consists of the horizontal stabilizer with its attached elevators and the vertical stabilizer with its attached rudder.

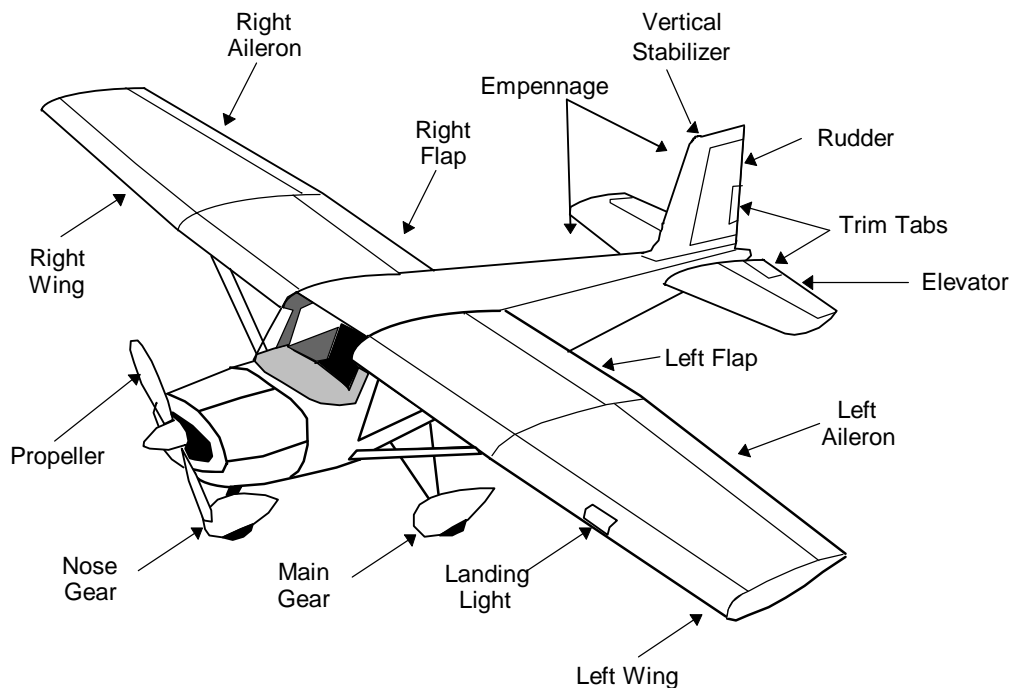

3. Aileron, elevator, flap and rudder movements control the aircraft in flight:
 - a. Ailerons are movable surfaces attached to the trailing edge of the wing, toward the wing tip from the flaps, that control roll (movement around the longitudinal axis). For example, if a pilot wants to turn to the right he turns the yoke to the right. This causes the right aileron to move up (creating a loss of lift on the right wing) and the left aileron to move down (creating lift on the left wing). The combined effects cause the aircraft to "roll" to the right.
 - b. The elevator is a movable surface attached to the trailing edge of the tail's horizontal stabilizer that controls pitch (movement of the nose up or down). For example, if a pilot wants to climb she pulls the yoke toward her. This causes the elevator to move up, creating a downward force on the tail and thus raising the nose.

- c. The flaps are electrically driven movable surfaces attached to the trailing edge of the wing, inboard of the ailerons. Deflection of the flaps (to a certain point) significantly increases lift. The pilot uses them during takeoff and landing.
- d. Rudders are movable surfaces attached to the trailing edge of the tail's vertical stabilizer that control yaw (side-to-side movement around the vertical axis). For example, if a pilot pushes the left rudder pedal the rudder swings to the left, creating a force that pushes the tail in the opposite direction (i.e., to the right). The nose of the aircraft then moves (yaws) to the left. [Note: the rudder pedals also move the aircraft nose wheel. When taxiing, to steer to the left the pilot would depress the left rudder pedal.]
- e. Although not a control surface, the throttle is a push rod with a black knob, located on the panel, that controls aircraft engine power. Pushing the knob in (towards the panel) increases power and pulling it out (towards you) decreases power.

Additional Information

More detailed information on this topic is available in Chapter 2 of the MART.

Evaluation Preparation

Setup: Provide the student access to an aircraft (or picture or model that shows aircraft control surfaces).

Brief Student: You are a Scanner trainee asked to identify and discuss the major aircraft control surfaces.

Evaluation

Performance measures

Results

- | | | |
|--|---|---|
| 1. Demonstrate and discuss how the pilot turns (rolls) the aircraft left or right. | P | F |
| 2. Demonstrate and discuss how the pilot makes the aircraft climb or dive. | P | F |
| 3. Demonstrate and discuss how the pilot moves the aircraft's nose to the left or right. | P | F |
| 4. Demonstrate and discuss how the pilot steers the aircraft to the left or right while taxiing. | P | F |
| 5. Demonstrate and discuss how the pilot increases or decreases engine power. | P | F |

Student must receive a pass on all performance measures to qualify in this task. If the individual fails any measure, show what was done wrong and how to do it correctly.

P-2017
IDENTIFY AND DISCUSS MAJOR AIRCRAFT INSTRUMENTS

CONDITIONS

You are a Mission Scanner trainee and must identify and discuss major aircraft instruments.

OBJECTIVES

Identify and discuss major aircraft instruments.

TRAINING AND EVALUATION

Training Outline

1. As a Mission Scanner trainee, basic knowledge of typical CAP aircraft instruments is helpful, particularly during an emergency.
2. Refer to MART Chapter 2 for pictures of the following instruments. The basic instruments are:
 - a. The *magnetic compass* shows the aircraft's heading in relationship to earth's magnetic North Pole.
 - b. The *heading indicator* is set to the magnetic compass. A gyroscope, it provides a steady reading that is easier for the pilot to read than the magnetic compass.
 - c. The *altimeter* shows altitude above mean sea level.
 - d. The *airspeed indicator* shows the speed at which the aircraft is moving through the air.
 - e. The *attitude indicator* (artificial horizon) is highly reliable and provides a very realistic picture of the attitude of the aircraft (turning, climbing or diving).
 - f. Other engine instruments provide fuel level and engine performance.
 - g. The global positioning system (*GPS*) is a satellite-based system that provides highly accurate position and velocity information (altitude, heading and speed).
 - i. The nav/comm (navigation/communications) *radios* allow the pilot or observer to communicate with air traffic control and other agencies.
 - j. The *audio panel* acts as the communications 'hub' of the aircraft. It allows the pilot or observer to select which radio is active, and directs other communication and navigation instruments to the crew headsets or the overhead speaker.
 - k. The *transponder* provides a signal to air traffic control that lets them know the aircraft's identification, position and altitude.
3. **Do not reposition any aircraft instrument's settings or controls without first asking the pilot.**

Additional Information

More detailed information on this topic is available in Chapter 2 of the MART.

Evaluation Preparation

Setup: Provide the student access to an aircraft (or a picture or model that shows aircraft instruments).

Brief Student: You are a Scanner trainee asked the basics about aircraft instruments.

Evaluation

Performance measures

Results

- | | | |
|--|---|---|
| 1. Identify and describe the basic function of the following aircraft instruments: | | |
| a. Magnetic compass | P | F |
| b. Heading indicator | P | F |
| c. Altimeter | P | F |
| d. Airspeed indicator | P | F |
| e. Attitude indicator | P | F |
| f. GPS | P | F |
| g. Radios | P | F |
| h. Audio panel | P | F |
| i. Transponder | P | F |
| 2. State the rule on repositioning any aircraft instrument's settings or controls. | P | F |

Student must receive a pass on all performance measures to qualify in this task. If the individual fails any measure, show what was done wrong and how to do it correctly.

P-2018
DISCUSS AIRCRAFT WEIGHT AND BALANCE

CONDITIONS

You are a Mission Scanner trainee and must discuss aircraft weight and balance.

OBJECTIVES

Discuss aircraft weight and balance criteria and describe the potential consequences of exceeding gross weight limits, and being "tail heavy" or "nose heavy."

TRAINING AND EVALUATION

Training Outline

1. As a Mission Scanner trainee, a basic knowledge of aircraft weight and balance and the consequences of exceeding weight and balance limits are essential.
2. The amount of lift produced by the aircraft is limited, so you must not load the aircraft beyond set limits. An overloaded aircraft may not be able to take off or may exhibit unexpected and potentially lethal flight characteristics. *Be honest about your weight and the weight of your luggage when loading the aircraft.*

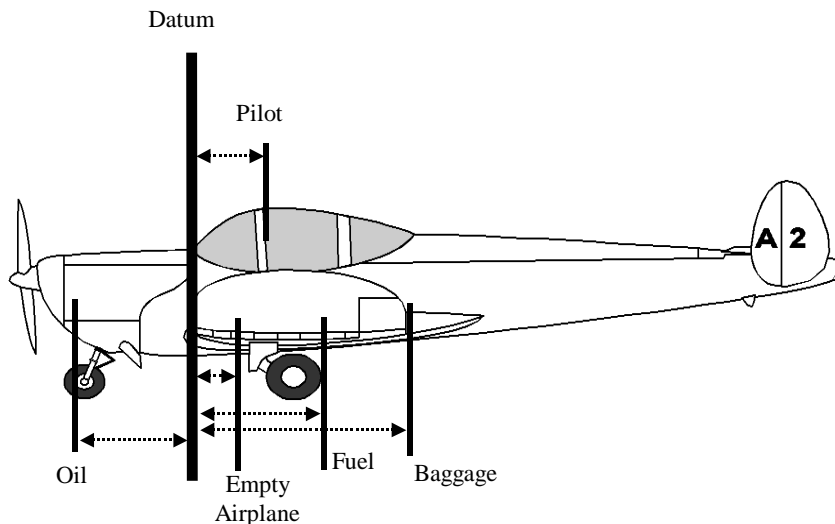

3. The weight of the aircraft and its instruments is called the "empty weight." For each flight the pilot computes further increases in weight for the items required for the flight. Examples are:
 - a. Fuel and oil. Fuel weighs approximately six pounds per gallon, so this is an important factor. On larger aircraft carrying a heavy load, the pilot may not fill the fuel tanks completely in order to meet weight limits. *This limits range and must be done carefully; re-check fuel status every hour.*
 - b. Pilot and crew, and everything they carry onboard.
 - c. Extra equipment that is permanently stowed in the aircraft. This includes tow bars, chocks, and survival gear.
4. Balance refers to the location of the center of gravity (c.g.) of an aircraft and is critical to stability and safety of flight.

- a. If the aircraft is loaded "tail heavy" the c.g. moves aft and the aircraft becomes less stable. In the worst case, this can make it difficult or impossible to recover from a stall.
 - b. If the aircraft is loaded "nose heavy" the c.g. moves forward. This can lead to a condition where the pilot cannot raise the aircraft's nose in slow flight conditions such as takeoff and landing.
5. The pilot computes the aircraft c.g. as part of the "Weight & Balance" calculations done before each flight. She then checks the c.g. to ensure it is within manufacturer's limitations.

Additional Information

More detailed information on this topic is available in Chapter 2 of the MART.

Evaluation Preparation

Setup: Access to an aircraft is desirable.

Brief Student: You are a Scanner trainee asked the basics about aircraft weight and balance and limits.

Evaluation

Performance measures

Results

- | | | |
|--|---|---|
| 1. Discuss the consequences of exceeding the aircraft's weight limit. | P | F |
| 2. Discuss the potential consequences of a "tail heavy" and a "nose heavy" aircraft. | P | F |
| 3. Discuss the importance of being accurate and honest about your and your luggage weight. | P | F |

Student must receive a pass on all performance measures to qualify in this task. If the individual fails any measure, show what was done wrong and how to do it correctly.

IDENTIFY ITEMS CHECKED DURING AN AIRCRAFT PRE-FLIGHT INSPECTION

CONDITIONS

You are a Mission Scanner trainee and must identify the items checked during an aircraft pre-flight inspection.

OBJECTIVES

Successfully identify the items checked during an aircraft pre-flight inspection.

TRAINING AND EVALUATION

Training Outline

1. As a Mission Scanner trainee, basic knowledge of the purpose of and the items checked during an aircraft pre-flight inspection is helpful.
2. A pre-flight inspection is a safety check and evaluation of the aircraft's condition for flight. This is the pilot's responsibility and should be performed with the aid of a checklist supplied by the manufacturer. If you are asked to help, you will probably read out each item on the checklist and the pilot will examine the item and acknowledge.

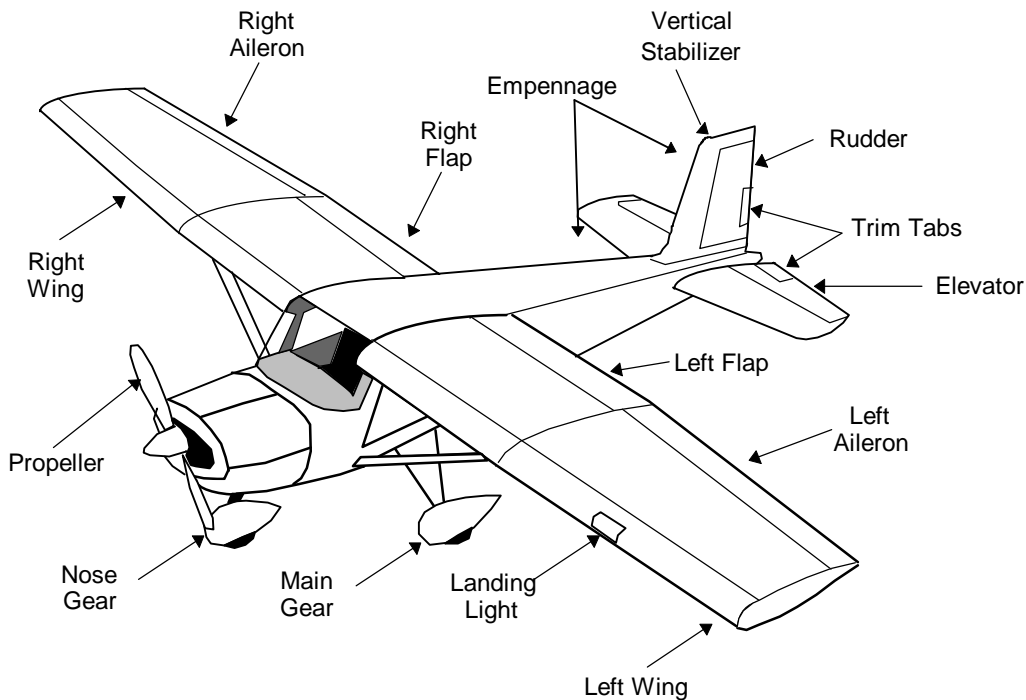

3. The "walk around" portion is an inspection of structural components and equipment. Other items are:
 - a. Fuel and oil. This includes "sumping" fuel and visually checking fuel levels in the tanks.
 - b. Landing, taxi, navigation and anti-collision lights.
 - c. Tires and brakes.
4. More pre-flighting takes place after the crew is buckled in, and other checklists are used for the various phases of flight (e.g., taxi, takeoff, climb, cruise, descent and landing).

Additional Information

More detailed information on this topic is available in Chapter 2 of the MART.

Evaluation Preparation

Setup: Provide the trainee access to an aircraft (or detailed model) and a typical pre-flight checklist.

Brief Student: You are a Scanner trainee asked the basics about pre-flight inspection.

Evaluation

Performance measures

Results

- | | | |
|---|---|---|
| 1. Discuss the purpose of an aircraft pre-flight inspection. | P | F |
| 2. Identify the major items checked during an aircraft pre-flight inspection. | P | F |

Student must receive a pass on all performance measures to qualify in this task. If the individual fails any measure, show what was done wrong and how to do it correctly.

P-2020
DISCUSS THE DANGERS OF WAKE TURBULENCE

CONDITIONS

You are a Mission Scanner trainee and must discuss the dangers of wake turbulence.

OBJECTIVES

Discuss wake turbulence, including where it is most likely to be encountered.

TRAINING AND EVALUATION

Training Outline

1. As a Mission Scanner trainee, knowledge of wake turbulence is helpful. *All crewmembers should assist the pilot in avoiding wake turbulence.* Wake turbulence is the disturbance of air caused by a large aircraft's movement. A spiral vortex is created around the aircraft wing tips.

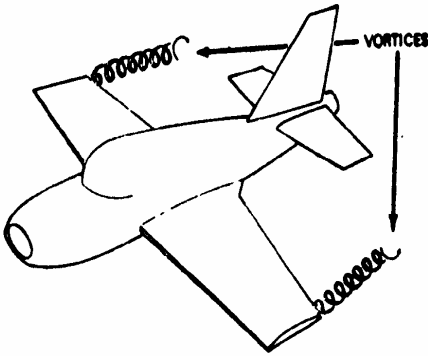

2. Large jets create the most severe wake turbulence when they are taking off or landing. In a no-wind situation the vortices spread outward and away from the wing tips, and sink beneath the aircraft. Vortices may remain active well after the aircraft that spawned them has passed.

- a. When taking off behind a large jet, the pilot should wait several minutes to take off. Also, she will try to lift off the runway before the point where the large jet lifted its nose wheel.
- b. When landing behind a large jet, the pilot should stay well above the jet's flight path and land beyond the point where the jet landed.



3. *All crewmembers should be alert to prevent the aircraft from taxiing too closely behind any large aircraft or helicopter.* The thrust produced by the engines can blow a small aircraft out of control, and can even flip it over. Rotor downwash from a helicopter can have a similar effect.

Additional Information

More detailed information on this topic is available in Chapter 2 of the MART.

Evaluation Preparation

Setup: Paper for drawings.

Brief Student: You are a Scanner trainee asked about wake turbulence.

Evaluation

Performance measures

Results

- | | | |
|--|---|---|
| 1. Discuss where wake turbulence is normally encountered. | P | F |
| 2. Discuss basic takeoff and landing precautions taken to avoid wake turbulence. | P | F |
| 3. Discuss the dangers of taxiing to close behind large jets or helicopters. | P | F |

Student must receive a pass on all performance measures to qualify in this task. If the individual fails any measure, show what was done wrong and how to do it correctly.

DISCUSS HOW ATMOSPHERIC AND LIGHTING CONDITIONS EFFECT SCANNING EFFECTIVENESS

CONDITIONS

You are a Mission Scanner trainee and must discuss how atmospheric and lighting conditions effect scanning effectiveness.

OBJECTIVES

Discuss how atmospheric and lighting conditions effect scanning effectiveness.

TRAINING AND EVALUATION

Training Outline

1. As a Mission Scanner trainee, knowing how atmospheric and lighting conditions effect scanning is essential. During daylight there are many factors that can affect the scanner's ability to spot the search target. The following table shows the (approximate) distance at which the scanner can sight various objects under average visibility conditions; factors that can alter these distances are discussed below.

Object	Distance
Person in life jacket (open water or moderate seas)	1/2 mile
Person in small life raft (open water or moderate seas)	3/4 mile
Person in open meadow within wooded area	1/2 mile or less
Crash in wooded area	1/2 mile
Crash on desert or open plain	2 miles
Person on desert or open plain	1 mile or less
Vehicle in open area	2 miles or less

During darkness, scanners make fewer fixations in their search patterns than during daylight because victims in distress are likely to use lights, fires, or flares to signal rescuers. Contrast between signal light and surrounding darkness eliminates the need for scanners to concentrate on making numerous eye fixations. An attentive scanner or observer should be able to see a light, flare, or fire easily during night operations. Search aircraft interior lighting should be kept to the lowest possible level that still allows normal chart reading. This will help the eyes adjust to the darkness and reduce glare on windshield and window surfaces. Red lights are used when flying at night because that color has little or no affect on the low-light adaptation of the human eye. Regardless of light conditions, a scanner should always maintain a systematic scanning pattern with fixations every few seconds. Darkness merely lengthens the interval between fixations.

2. Atmospheric conditions. All aircrews hope for perfect visibility during a SAR mission, but this atmospheric condition rarely exists. Most of the time the atmosphere (especially the lower atmosphere) contains significant amounts of water vapor, dust, pollen, and other particles. These items block vision according to their density. Of course, the farther we try to see the more particles there are and the more difficult it is to sight the objective.
3. Position of the sun. Flying “into the sun,” soon after it rises in the morning or before it sets in the afternoon, poses visibility problems. No doubt you have had this experience while driving or riding as a crewmember in an automobile. Recall how difficult it is to distinguish colors and to detect smaller objects.
4. Clouds and shadows. Shadows produced by clouds can reduce the effective scanning range. This is due to the high contrast between sunlit area and shadows. Our eyes have difficulty adjusting to such contrasts. The same effect occurs in mountainous areas where bright sunlight causes the hills and mountains to cast dark

shadows. Heavy cloud cover can "wash out" colors on the ground, making wreckage and colored clothes or signal devices harder to sight.

5. Terrain and ground cover. The more intensive search efforts occur over terrain that is either mountainous or covered with dense vegetation, or both. Mountainous area searches demand frequent variation in the scanning range. This you can visualize fairly easily; at one moment the mountain or hill places the surface within, say 200 feet of the aircraft. Upon flying past the mountain or hill the surface suddenly may be a half-mile away. Forested areas can reduce the effective scanning range dramatically. This is especially true during spring, summer, and fall when foliage is most pronounced. The situation doesn't change for the better in the winter where trees are of the evergreen types-pine, spruce, etc.-because the height of the trees plus their foliage masks the search objective very effectively. Frequently the only way for a scanner to actually spot an objective under such circumstance is to be looking down almost vertically. There are other signs to look for in such areas, but we will discuss them later.

6. Surface conditions. Here we are thinking of snow, primarily. Even a thin covering of new snow will change the contour, or shape, of a search objective. Also, the light-reflective quality of snow affects visual effectiveness. The net result is a need to bring the scanning range nearer to the aircraft.

7. Cleanliness of windows. This might seem to be a very minor factor. On the other hand, it is estimated that the scanner's visibility can be reduced up to 50 percent if the aircraft window isn't clean. If you discover this to be the case in your aircraft, clean the window yourself. However, aircraft windows are made of plastic and they are easily scratched. Ask the pilot what cleaning materials and methods are acceptable before cleaning the window. Window cleaning is a normal part of pre- and post-flight activities.

8. Use of binoculars, cameras, and sunglasses. Binoculars rapidly bring on eye fatigue when used in an aircraft, and may lead to disorientation and airsickness. They should only be used for *brief* periods to check sightings or for detailed viewing of an assessment area or target. Looking through a camera or camcorder viewfinder for extended periods can be equally as discomforting. Take breaks whenever possible. Sunglasses are an important tool for aircrew, reducing eye fatigue and glare: however, sunglasses do have some negative aspects. Looking through the aircraft windshield with polarized lenses can result in a reduced retinal image. Also, color discrimination is reduced while wearing dark lenses. And, of course, if you are looking for a lost person wearing a blue jacket, don't wear sunglasses with "blue-blocking" lenses. Finally, no matter how cool it may look, don't wear sunglasses while flying in low visibility conditions (i.e., overcast and at dawn, dusk or night).

Additional Information

More detailed information on this topic is available in Chapter 5 of the MART.

Evaluation Preparation

Setup: None.

Brief Student: You are a Scanner trainee asked about how atmospheric and lighting conditions effect scanning.

Evaluation

Performance measures

Results

1. Discuss how atmospheric and lighting conditions effect scanning effectiveness.

P F

Student must receive a pass on all performance measures to qualify in this task. If the individual fails any measure, show what was done wrong and how to do it correctly.

P-2022
IDENTIFY VISUAL CLUES AND WRECKAGE PATTERNS

CONDITIONS

You are a Mission Scanner trainee and must identify and discuss typical visual clues and wreckage patterns.

OBJECTIVES

Identify and discuss typical visual clues and wreckage patterns.

TRAINING AND EVALUATION

Training Outline

1. As a Mission Scanner trainee, knowing what to look for in the search area is essential. If you have not had much experience at "looking down" while flying, there are some surprises in store for you. Objects appear quite different when they are seen from above and at a greater distance than usual. Even if you are very familiar with the territory as seen from the surface, scanning it from the air will reveal features and objects you had no idea were there.
2. Typical visual clues. Anything that appears to be out of the ordinary should be considered a clue to the location of the search objective. In addition to this piece of advice, the following are specific clues for which scanners should be looking: [refer to the Scanner slides for pictures]

Light colored or shiny objects - Virtually all aircraft have white or other light colors as part of their paint schemes. Some aircraft have polished aluminum surfaces that provide contrast with the usual ground surface features and will "flash" in bright sunlight. Aircraft windshields and windows also have a reflective quality about them: if the angle of the sun is just right, you will pick up momentary flashes with either your central or peripheral vision. A flash from any angle deserves further investigation.

Smoke and fire - Sometimes aircraft catch fire when they crash. If conditions are right, the burning airplane may cause forest or grass fires. Survivors of a crash may build a fire to warm themselves or to signal search aircraft.

Blackened areas - Fire causes blackened areas. You may have to check many such areas (see false clues), but finding the search objective will make the effort worthwhile.

Broken tree branches - If an airplane goes down in a heavily wooded area, it will break tree branches and perhaps trees. The extent of this breakage will depend on the angle at which the trees were struck. The primary clue for the scanner, however, will be color. As you no doubt realize, the interior of a tree trunk or branch and the undersides of many types of leaves are light in color. This contrast between the light color and the darker foliage serves as a good clue.

Local discoloration of foliage - Here we are talking about dead or dying leaves and needles of evergreen trees. A crash that is several days old may have discolored a small area in the forest canopy. This discoloration could be the result of either a small fire or broken tree branches.

Fresh bare earth - An aircraft striking the ground at any angle will disturb or "plow" the earth to some degree. An overflight within a day or so of the event should provide a clue for scanners. Because of its moisture content, fresh bare earth has a different color and texture than the surrounding, undisturbed earth.

Breaks in cultivated field patterns - Crop farmlands always display a pattern of some type, especially during the growing season. Any disruption of such a pattern should be investigated. A crop such as corn could mask the presence of small aircraft wreckage, but the pattern made by the crashing airplane may stand out as a break in uniformity.

Water and snow - Water and snow are not visual clues, but they often contain such clues. For example, when an aircraft goes down in water its fuel and probably some oil will rise to the water's surface making an "oil slick" discoloration. Other material in the aircraft may also discolor the water or float as debris. If the aircraft hasn't been under the water very long, air bubbles will disturb the surface. Snow readily shows clues. Any discoloration caused by fire, fuel or debris will be very evident.

Tracks and signals - Any line of apparent human tracks through snow, grass, or sand should be regarded as possibly those of survivors.

Birds and animals - Scavenger birds (such as vultures and crows), wolves, and bears may gather at or near a crash site. Vultures (or buzzards) sense the critical condition of an injured person and gather nearby to await the person's death. If you see these birds or animals in a group, search the area thoroughly.

False clues - Examples are campfires and other purposely set fires, oil slicks that may have been caused by spillage from ships; and trash piles or pits. Aircraft parts may not have been removed from other crash sites, although some of the aircraft parts may have been marked with a yellow "X" (you may not be able to see the mark until near the site because the paint has faded or worn off with age).

Survivors and Signals - If there are survivors and if they are capable of doing so, they will attempt to signal you. The type of signal the survivors use will depend on how much they know about the process and what type signaling devices are available to them.

Nighttime signals - For various reasons, nighttime air searches are very infrequent. Light signals of some type will be the only clue to the search objective location. A fire or perhaps a flashlight will be the survivor's means of signaling. On the other hand, a light signal need not be very bright: one survivor used the flint spark of his cigarette lighter as a signal and he was rescued.

3. Wreckage patterns. Frequently, there are signs near a crash sight that the aircrew can use to locate the actual wreckage. The environment plays a major role in sighting the signs from the search aircraft. In crashes at sea, searchers may be unable to locate the crash site as rough seas can scatter wreckage or signs quickly. On land, the wreckage may be in dense foliage that can obscure it in a matter of days. By knowing signs to look for, the scanner can improve the effectiveness of each sortie. In general, don't expect to find anything that resembles an aircraft; most wrecks look like hastily discarded trash. However, certain patterns do result from the manner in which the accident occurred.

The hole in the ground is caused from steep dives into the ground or from flying straight into steep hillsides or canyon walls. Wreckage is confined to a small circular area around a deep, high-walled, narrow crater. The structure may be completely demolished with parts of the wings and empennage near the edge of the crater. Vertical dives into heavily wooded terrain will sometimes cause very little damage to the surrounding foliage, and sometimes only a day or two is needed for the foliage to repair itself.

The corkscrew (auger) is caused from uncontrolled spins. Wreckage is considerably broken in a small area. There are curved ground scars around a shallow crater. One wing is more heavily damaged and the fuselage is broken in several places with the tail forward in the direction of the spin. In wooded areas, damage to branches and foliage is considerable, but is confined to a small area.

Creaming (smear) is often caused from low-level "buzzing" or an attempted crash landing. The wreckage distribution is long and narrow with heavier components farthest away from the initial point of impact. The tail and wings remain fairly intact and sheared off close to the point of impact. Ground looping sometimes terminates the wreckage pattern with a sharp hook and may reverse the position of some wreckage components. Skipping is also quite common in open, flat terrain. In wooded areas, damage to the trees is considerable at the point of impact, but the wreckage travels among the trees beneath the foliage for a greater distance and may not be visible from the air.

The *four winds* result from mid-air collisions, explosion, or in-flight break up. Wreckage components are broken up and scattered over a wide area along the flight path. The impact areas are small but chances of sighting them are increased by the large number of them.

Hedge trimming is caused when an aircraft strikes a high mountain ridge or obstruction but continues on for a considerable distance before crashing. Trees or the obstruction are slightly damaged or the ground on the crest is lightly scarred. Some wreckage components may be dislodged; usually landing gear, external fuel tanks, cockpit canopy, or control surfaces. The direction of flight from the hedge trimming will aid in further search for the main scene.

A *splash* is caused when an aircraft has gone down into water: oil slicks, foam, and small bits of floating debris are apparent for a few hours after the impact. With time, the foam dissipates, the oil slicks spread and streak, and the debris become widely separated due to action of wind and currents. Sometimes emergency life rafts are ejected but, unless manned by survivors, will drift very rapidly with the wind. Oil slicks appear as smooth, slightly discolored areas on the surface and are in evidence for several hours after a splash; however, they are also caused by ships pumping their bilges and by offshore oil wells or natural oil seepage. Most aircraft sink very rapidly after ditching.

Additional Information

More detailed information on this topic is available in Chapter 5 of the MART.

Evaluation Preparation

Setup: Provide the student with pictures of typical crash clues and wreckage patterns (e.g., Scanner slides).

Brief Student: You are a Scanner trainee asked what to identify and discuss typical crash clues and wreckage patterns.

Evaluation

Performance measures

Results

1. Identify and discuss typical visual crash clues and wreckage patterns.

P F

Student must receive a pass on all performance measures to qualify in this task. If the individual fails any measure, show what was done wrong and how to do it correctly.

DISCUSS HOW REDUCED VISIBILITY AND TURBULENCE EFFECT SEARCH OPERATIONS

CONDITIONS

You are a Mission Scanner trainee and must discuss how reduced visibility and turbulence effect search operations.

OBJECTIVES

Discuss reduced visibility and turbulence, and how they effect search operations.

TRAINING AND EVALUATION

Training Outline

1. As a Mission Scanner trainee, understanding the causes of reduced visibility and turbulence and how this effects search operations is very useful.
2. Reduced visibility. One of the most common hazardous-weather problems is loss of visibility. Visibility may be reduced by many conditions including clouds, rain, snow, fog, haze, smoke, blowing dust, sand, and snow. A similar condition called "white out" can occur where there has been snowfall.
3. Effects. This can happen either suddenly or very insidiously, depriving the pilot of his ability to see and avoid other aircraft, and reducing or depriving him altogether of his ability to control the aircraft, unless he has had training and is proficient in instrument flying. In reduced visibility, the crew's ability to see rising terrain and to avoid towers, power transmission lines, and other man-made obstacles is diminished.

Frequently, as the sun warms the cool, hazy air and causes it to expand and rise, visibility at the surface will improve and appear acceptable. What initially appeared to be ample visibility can, after takeoff, become almost a complete obstruction to lateral or forward visibility several hundred feet above the surface. Downward visibility is satisfactory, but pilots may feel apprehensive about the loss of a visible horizon to help judge aircraft control, and about what might come out of the murk ahead. Visibility at this altitude may actually be more than the minimum three miles, yet the pilot may interpret this visual range as a wall just beyond the airplane's nose.

When haze and smoke are present, the best measure a flight crew can take to minimize risk of such an encounter is to get a thorough weather briefing before flying, and update the briefing by radio with *Flight Watch* as required.

Each member of the aircrew must be vigilant during all phases of the flight when visibility is less than perfect. Crew resource management requires that each member of the crew be assigned an area to search during the takeoff, transit and approach-to-landing phases of the flight in order to help the pilot "see and avoid" obstacles and other aircraft. The aircrew must also characterize visibility in the search area so as to establish the proper scanning range (see Chapter 5). Search visibility may be different than expected, and your search pattern may have to be adjusted accordingly. Be sure to cover this during your debriefing.

4. Turbulence. Turbulence is irregular atmospheric motion or disturbed wind flow that can be attributed to a number of causes. Turbulence can be inconsequential, mildly distracting, nauseating, or destructive depending on its intensity. Turbulence can often be avoided by changing altitudes. Aircraft manufacturers publish "maneuvering speeds" in the operating handbooks: if the aircraft stays below the maneuvering airspeed no structural damage should occur.

Just as a tree branch dangling into a stream creates continuous ripples or waves of turbulence in the water's surface, obstructions to the wind can create turbulence in the air. This type of turbulence occurs mostly close to the ground, although depending upon wind velocity and the nature of the obstruction, it may reach upward several thousand feet. In an extreme case, when winds blow against a mountainside, the mountain deflects the wind upward creating a relatively smooth updraft. Once the wind passes the summit, it tumbles down the leeward or downwind side, forming a churning, turbulent down draft of potentially violent intensity. The churning turbulence can then develop into *mountain waves* that may continue many miles from the mountain ridge. Mountain waves may be a factor when surface winds are as little as 15 knots.

5. Effects. Turbulence can become a major factor in search effectiveness. Any scanner who is uncomfortable or nauseous cannot perform her duties at a very high level of effectiveness. If you experience these sensations, inform the pilot immediately. If turbulence detracted from your concentration during the search, be sure to mention this during debriefing.

Additional Information

More detailed information on this topic is available in Chapter 6 of the MART.

Evaluation Preparation

Setup: None.

Brief Student: You are a Scanner trainee asked to discuss turbulence and its affects on search operations.

Evaluation

<u>Performance measures</u>	<u>Results</u>
1. Discuss the causes of reduced visibility.	P F
2. Discuss how reduced visibility effects search operations, and related precautions.	P F
3. Discuss the causes of turbulence.	P F
4. Discuss how turbulence effects search operations, and precautions.	P F

Student must receive a pass on all performance measures to qualify in this task. If the individual fails any measure, show what was done wrong and how to do it correctly.

DISCUSS STRATEGIES TO COMBAT HIGH ALTITUDE EFFECTS

CONDITIONS

You are a Mission Scanner trainee and must discuss how to recognize and combat high altitude effects.

OBJECTIVES

Discuss high altitude effects and demonstrate strategies to deal with them.

TRAINING AND EVALUATION

Training Outline

1. As a Mission Scanner trainee, knowing how high altitude effects you and your crew and strategies to deal with the effects is essential.
2. Dehydration. When operating in high altitudes or temperatures, body water is continuously expired from the lungs and through the skin: this physiological phenomenon is called insensible perspiration or insensible loss of water. Water loss is increased in flight because of the relatively lowered humidity at altitude, particularly on extended flights. Typical dehydration conditions are: dryness of the tissues and resulting irritation of the eyes, nose, and throat, and fatigue relating to the state of acidosis (reduced alkalinity of the blood and body tissues). A person reporting for a flight in a dehydrated state will more readily notice these symptoms until fluids are adequately replaced.

When operating in high altitudes or temperatures, crewmembers should make every effort to drink plenty of water, juice, or caffeine-free soft drinks prior to, during, and after each mission to help prevent dehydration. Consumption of coffee, tea, cola, and cocoa should be minimized since these drinks contain caffeine. In addition, tea contains a related drug (theophylline), while cocoa (and chocolate) contain theobromine, of the same drug group. These drugs, besides having a diuretic effect, have a marked stimulating effect and can cause an increase in pulse rate, elevation of blood pressure, stimulation of digestive fluid formation, and irritability of the gastrointestinal tract.

Increasing the flow of outside air through the aircraft interior by the use of vents, or opening windows or hatches can usually remedy heat-related problems. If sufficient airflow cannot be gained, cooler air can usually be located by climbing the aircraft to a higher altitude. This may be inconsistent with search altitudes assigned by the incident commander or may be beyond the performance capability of the aircraft.

3. Ear block. As the aircraft cabin pressure decreases during ascent, the expanding air in the middle ear pushes the Eustachian tube open and, by escaping down it to the nasal passages, equalizes in pressure with the cabin pressure. But during descent, passengers must periodically open their Eustachian tube to equalize pressure. This can be accomplished by swallowing, yawning, tensing muscles in the throat or, if these do not work, by the combination of closing the mouth, pinching the nose closed and attempting to blow through the nostrils (Valsalva maneuver).
4. Sinus block. During ascent and descent, air pressure in the sinuses equalizes with the aircraft cabin pressure through small openings that connect the sinuses to the nasal passages. Either an upper respiratory infection, such as a cold or sinusitis, or a nasal allergic condition can produce enough congestion around the opening to slow equalization and, as the difference in pressure between the sinus and cabin mounts, eventually plug the opening. This "sinus block" occurs most frequently during descent. A sinus block is prevented by not flying with an upper respiratory infection or nasal allergic condition. Adequate protection is usually not provided by

decongestant sprays or drops to reduce congestion around the sinus openings. Oral decongestants have side effects that can impair pilot performance. If a sinus block does not clear shortly after landing, a physician should be consulted.

5. Hypoxia. Hypoxia is a state of oxygen deficiency in the body sufficient to impair functions of the brain and other organs. Hypoxia from exposure to altitude is due only to the reduced barometric pressures encountered at altitude, for the concentration of oxygen in the atmosphere remains about 21 percent from the ground out to space. *The body has no built-in warning system against hypoxia.* Although deterioration in night vision occurs at a cabin pressure altitude as low as 5,000 feet, other significant effects of altitude hypoxia usually do not occur in the normal healthy person below 12,000 feet. From 12,000 to 15,000 feet of altitude, judgment, memory, alertness, coordination and ability to make calculations are impaired. Headache, drowsiness, dizziness and either a sense of euphoria or belligerence may also occur. In fact, pilot performance can seriously deteriorate within 15 minutes at 15,000 feet.

Hypoxia can be prevented by: heeding factors that reduce tolerance to altitude, by enriching the inspired air with oxygen from an appropriate oxygen system and by maintaining a comfortable, safe cabin pressure altitude. For optimum protection, pilots are encouraged to use supplemental oxygen above 10,000 feet during the day, and above 5,000 feet at night. The Federal Aviation Regulations require that the minimum flight crew be provided with and use supplemental oxygen after 30 minutes of exposure to cabin pressure altitudes between 12,500 and 14,000 feet, and immediately on exposure to cabin pressure altitudes above 14,000 feet. Every occupant of the aircraft must be provided with supplement oxygen at cabin pressure altitudes above 15,000 feet.

Additional Information

More detailed information on this topic is available in Chapter 7 of the MART.

Evaluation Preparation

Setup: None.

Brief Student: You are a Scanner trainee asked to discuss the effects of high altitude on the body and strategies to deal with the conditions.

Evaluation

<u>Performance measures</u>	<u>Results</u>
1. Discuss the symptoms and dangers of the following:	
a. Ear block.	P F
b. Sinus block.	P F
c. Hypoxia.	P F
2. Discuss strategies used to combat these symptoms.	P F

Student must receive a pass on all performance measures to qualify in this task. If the individual fails any measure, show what was done wrong and how to do it correctly.

P-2025
DISCUSS COMMON SEARCH TERMS

CONDITIONS

You are a Mission Scanner trainee and must discuss the common search terms used during a typical mission.

OBJECTIVES

Discuss common search terms used during a typical mission.

TRAINING AND EVALUATION

Training Outline

1. As a Mission Scanner trainee, basic knowledge of search terms is helpful. A number of terms and planning factors should be understood in order to better understand search and rescue missions.
2. Ground and Search Track. Ground track is an imaginary line on the ground that is made by an aircraft's flight path over the ground. The search track is an imaginary swath across the surface, or ground (the scanning range and the length of the aircraft's ground track forms its dimensions).
3. Maximum Area of Possibility. This normally circular area is centered at the missing airplane's (or search objective's) last known position (LKP), corrected for the effect of wind. The circle's radius represents the maximum distance a missing aircraft might have flown based on estimated fuel endurance time and corrected for the effects of the wind over that same amount of time. The radius may also represent the maximum distance survivors might have traveled on foot, corrected for environmental or topographical conditions, such as snow, wind, mountains, and rivers.
4. Meteorological and Search Visibility. Meteorological visibility refers to the maximum range at which large objects (such as a mountain) can be seen, whereas search visibility refers to the distance at which an object the size of an automobile on the ground can be seen and recognized from an aircraft in flight. Search visibility is always less than meteorological visibility. [Note: The maximum search visibility listed on the POD chart is four nautical miles.]
5. Probability Area. This is a smaller area, within the maximum possibility area, where there is an increased likelihood of locating the objective aircraft or survivor. Distress signals, sightings, radar track data, and the flight plan are typical factors that help define the probability area's boundaries.
6. Probability of Detection. The likelihood, expressed in a percent, that a search airplane might locate the objective. Probability of detection (POD) can be affected by weather, terrain, vegetation, skill of the search crew, and numerous other factors. When planning search missions, it is obviously more economical and most beneficial to survivors if we use a search altitude and track spacing that increases POD to the maximum, consistent with the flight conditions, team member experience levels, and safety. Note: POD will be decreased if only one scanner is on board and the search pattern is not adjusted accordingly.
7. Scanning Range. Scanning range refers to the lateral distance from a scanner's search aircraft to an imaginary line on the ground parallel to the search aircraft's ground track. Within the area formed by the ground track and scanning range, the scanner is expected to have a good chance at spotting the search objective. Scanning range can be the same as or shorter than the search visibility.

8. Search Altitude. This is the altitude that the search aircraft flies above the ground (AGL). [Remember, routine flight planning and execution deals in MSL, while searches and assessments are referenced to AGL.]
9. Track Spacing. This is the distance (S) between adjacent ground tracks. The idea here is for each search track to either touch or slightly overlap the previous one.

Additional Information

More detailed information on this topic is available in Chapter 9 of the MART.

Evaluation Preparation

Setup: Provide the student with a sectional chart and a mission scenario that uses all the search terms.

Brief Student: You are a Scanner trainee asked to demonstrate and discuss search terms used during a typical mission.

Evaluation

<u>Performance measures</u>	<u>Results</u>
1. Use and discuss search terms used during a typical mission:	
a. Ground and Search track.	P F
b. Maximum Area of Probability, Probability Area, and Probability of Detection.	P F
c. Meteorological and Search visibility.	P F
d. Scanning range.	P F
e. Search altitude and Track spacing.	P F

Student must receive a pass on all performance measures to qualify in this task. If the individual fails any measure, show what was done wrong and how to do it correctly.

IDENTIFY WHAT TO LOOK FOR AND RECORD DURING DAMAGE ASSESSMENT MISSIONS

CONDITIONS

You are a Mission Scanner trainee and must identify things to look for and record during damage assessment missions.

OBJECTIVES

Discuss damage assessment missions, including what questions you should ask, what you should look for, and what information you should record over the site.

TRAINING AND EVALUATION

Training Outline

1. As a Mission Scanner trainee, basic knowledge of damage assessment missions is essential. Flying damage assessment sorties is not much different than flying search patterns. The big difference between a search for a downed aircraft and damage assessment is *what you look for* in the disaster area. Different types of emergencies or disasters will prompt different assessment needs, as will the nature of the operations undertaken.

The conditions that created the emergency or disaster may affect CAP operations. Extreme weather is an obvious concern, and must be considered in mission planning. The disaster may affect the physical landscape by erasing or obscuring landmarks. This may make navigation more difficult and may render existing maps obsolete.

Disasters may also destroy or render unusable some part of the area's infrastructure (e.g., roads, bridges, airfields, utilities and telecommunications). This can hamper mobility and continued operations. Also, road closures by local authorities or periodic utility outages can reduce the effectiveness and sustainability of CAP operations in the area.

2. Most often you will be given specific tasking for each sortie. However, you must always be observant and flexible. Just because you have been sent to determine the condition of a levy doesn't mean you ignore everything else you see on the way to and from the levy. Examples of questions you should be asking are (but are certainly not limited to):

- a. What is the geographical extent of the affected area?
- b. What is the severity of the damage?
- c. Is the damage spreading? If so: how far and how fast? It is particularly important to report the direction and speed of plumes (e.g., smoke or chemical).
- d. How has access to or egress from important areas been affected? For example, you may see that the southern road leading to a hospital has been blocked, but emergency vehicles can get to the hospital using an easterly approach.
- e. What are the primary active hazards in the area? Are there secondary hazards? For example, in a flood the water is the primary hazard; if the water is flowing through an industrial zone then chemical spills and fumes may be secondary hazards.
- f. Is the disaster spreading toward emergency or disaster operating bases, or indirectly threatening these areas? For example, is the only road leading to an isolated aid station about to be flooded?
- g. Have utilities been affected by the emergency or disaster? Look for effects on power transmission lines, power generating stations or substations, and water or sewage treatment facilities.
- h. Can you see alternatives to problems? Examples are alternate roads, alternate areas to construct aid stations, alternate landing zones, and locations of areas and facilities unaffected by the emergency or disaster.

3. It is very important to have local maps on which you can indicate damaged areas, as it is difficult to record the boundaries of large areas using lat/long coordinates.
4. Some specific things to look for during a damage assessment sortie are:
 - a. Breaks in pavement, railways, bridges, dams, levees, pipelines, runways, and structures.
 - b. Roads/streets blocked by water, debris or landslide (same for helipads and runways).
 - c. Downed power lines.
 - d. Ruptured water lines (this may have a major impact on firefighting capabilities).
 - e. Motorists in distress or major accidents.
 - f. Alternate routes for emergency vehicles or evacuation.
 - g. Distress signals from survivors.
5. At each site, besides sketching or highlighting the extent of the damage on local maps and identifying access/egress routes, you should record:
 - a. Lat/long and time.
 - b. Description.
 - c. Type and extent of damage.
 - d. Photo number or time reference for videotape.
 - e. Status (e.g., the fire is out, the fire is spreading to the northeast, or the floodwaters are receding).
6. An individual is very difficult to spot from the air, but CAP aircraft can do well in some situations:
 - a. Persons who are simply lost and are able to assist in their rescue. Persons who frequent the outdoors are often trained in survival and have the means to signal searching aircraft.
 - b. Persons who may be wandering along roads or highways, such as Alzheimer's patients.
 - c. Persons trapped or isolated by natural disasters such as floods. These persons often can be found on high ground, on top of structures, along a road or riverbank.
 - d. Persons who were driving. Their vehicle may be stopped along a road or highway.

Lost children and people with diminished capacities can be especially difficult to find. By the time CAP is called the police have probably already looked in the obvious places. Often, these individuals will be hiding from their searchers. Route and grid searches must be done with great care and with full, well-rested crews. Knowledge of what they are wearing and how they may respond to over-flying aircraft is especially valuable in these instances. Lost persons often fight topography and are likely to be found in the most rugged portion of the surrounding country (persons who follow natural routes are seldom lost for long periods). Children under five years old frequently travel uphill; they also may hide from searchers (except at night).

Additional Information

More detailed information on this topic is available in Chapter 9 of the MART.

Evaluation Preparation

Setup: Provide the student with typical damage assessment mission scenarios and pictures.

Brief Student: You are a Scanner trainee asked to discuss damage assessment missions.

Evaluation

Performance measures

Results

- | | | |
|---|---|---|
| 1. Discuss how a disaster can effect CAP operations. | P | F |
| 2. Discuss the types of questions you should ask yourself during DA sorties. | P | F |
| 3. Identify and discuss the typical things you should look for during DA sorties. | P | F |
| 4. State the information you should record during DA sorties. | P | F |
| 5. Discuss the limitations of an air search for a missing person. | P | F |

Student must receive a pass on all performance measures to qualify in this task. If the individual fails any measure, show what was done wrong and how to do it correctly.

P-2027
DESCRIBE CAP SEARCH PATTERNS

CONDITIONS

You are a Mission Scanner trainee and must describe CAP search patterns.

OBJECTIVES

Describe the four most common CAP search patterns.

TRAINING AND EVALUATION

Training Outline

1. As a Mission Scanner trainee, understanding CAP search patterns is very helpful. This allows you to anticipate events.
2. Route search pattern. The route (track line) search pattern is normally used when an aircraft has disappeared without a trace. This search pattern is based on the assumption that the missing aircraft has crashed or made a forced landing on or near its intended track (route). It is assumed that detection may be aided by survivor signals or by electronic means. The track line pattern is also used for night searches (in suitable weather). A search aircraft using the track line pattern flies a rapid and reasonably thorough coverage on either side of the missing aircraft's intended track.

Search altitude for the track line pattern usually ranges from 1000 feet above ground level (AGL) to 2000 feet AGL for day searches, while night searches range 2000 to 3000 feet AGL (either depending upon light conditions and visibility). Lat/long coordinates for turns are determined and then entered into the GPS as waypoints, which may then be compiled into a flight plan.

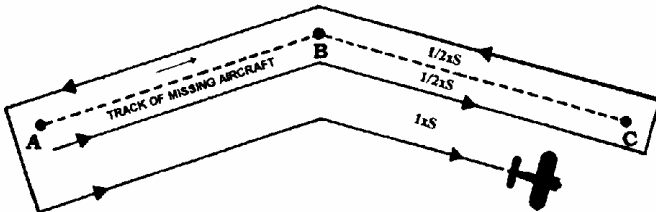

The search crew begins by flying parallel to the missing aircraft's intended course line, using the track spacing (labeled "S") determined by the incident commander or planning section chief. On the first pass, recommended spacing may be one-half that to be flown on successive passes. Flying one-half "S" track spacing in the area where the search objective is most likely to be found can increase search coverage.

3. Parallel track search pattern. The parallel track (sweep) search pattern is normally used when one or more of the following conditions exist: a) the search area is large and fairly level, b) only the approximate location of the target is known, or c) uniform coverage is desired. This type of search is used to search a grid.

The aircraft proceeds to a corner of the search area and flies at the assigned altitude, sweeping the area maintaining parallel tracks. The first track is at a distance equal to one-half ($1/2$) track spacing (S) from the side of the area.

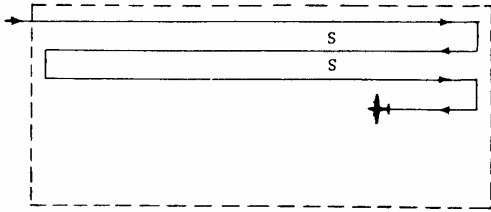

4. Creeping line search pattern. The creeping line search pattern is similar to the parallel patterns. The parallel pattern search legs are aligned with the major, or longer, axis of the rectangular search areas, whereas the search legs of the creeping line pattern are aligned with the minor or shorter axis of rectangular search areas. The creeping line pattern is used when: a) the search area is narrow, long, and fairly level, b) the probable location of the target is thought to be on either side of the search track within two points, or c) there is a need for immediate coverage of one end of the search area.

The creeping line is a succession of search legs along a line. The starting point is located one-half search track spacing inside the corner of the search area.

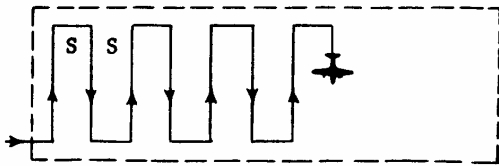

5. Expanding Square search pattern. The expanding square search pattern is used when the search area is small (normally, areas less than 20 miles square), and the position of the survivors is known within close limits. This pattern begins at an initially reported position and expands outward in concentric squares. If error is expected in locating the reported position, or if the target were moving, the square pattern may be modified to an expanding rectangle with the longer legs running in the direction of the target's reported, or probable, movement.

If the results of the first square search of an area are negative, the search unit can use the same pattern to cover the area more thoroughly. The second search of the area should begin at the same point as the first search; however, the first leg of the second search is flown diagonally to the first leg of the first search. Consequently, the entire second search diagonally overlays the first one. The bold, unbroken line in the figure illustrates the first search, while the dashed line represents the second search. Track spacing indicated in the figure is "cumulative," showing the total width of the search pattern at a given point on that leg. Actual distance on a given leg from the preceding leg on the same side of the pattern is still only one "S," the value determined by the incident commander or planning section chief.

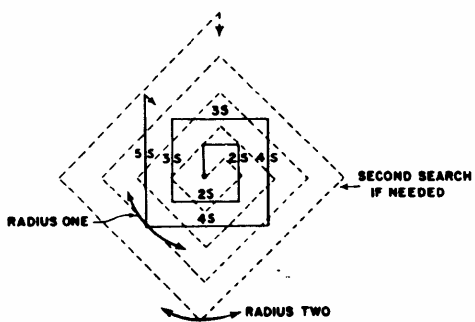

Additional Information

More detailed information and figures on this topic are available in Chapter 11 of the MART.

Evaluation Preparation

Setup: Provide the student with a sectional and descriptions of each search pattern.

Brief Student: You are a Scanner trainee asked to describe the most common CAP search patterns.

Evaluation

Performance measures

Results

1. Describe the following search patterns:

- | | | |
|---------------------|---|---|
| a. Route | P | F |
| b. Parallel | P | F |
| c. Creeping line | P | F |
| d. Expanding square | P | F |

Student must receive a pass on all performance measures to qualify in this task. If the individual fails any measure, show what was done wrong and how to do it correctly.

P-2028
DISCUSS CREW RESOURCE MANAGEMENT

CONDITIONS

You are a Mission Observer trainee and must discuss Crew Resource Management (CRM).

OBJECTIVES

Discuss how CRM is used in CAP activities and missions.

TRAINING AND EVALUATION

Training Outline

1. As a Mission Observer trainee, knowing how to employ effective crew resource management is essential to safety.
2. *Situational Awareness*. Simply put, situational awareness (SA) is "knowing what is going on around you at all times." SA is not restricted to just pilots -- everyone must exhibit SA at all times. Each crewmember must have their SA at peak levels while flying because it takes everyone's awareness to keep the plane safe in flight. Scanners and observers have their own unique positions and functions that require full attention, so their SA is essential to the safe operation of any CAP flight.

Examples of good SA attitudes are:

Good mental health, where each crewmember is clear and focused.

Good physical health: this includes fatigue, sickness, hydration, and stress factors.

Attentiveness: keep your attention on the task at hand.

Inquisitiveness: always asking questions, challenging ideas, and asking for input.

Examples of SA skills:

Professional skills developed through training, practice and experience.

Good communication skills. These are necessary to effectively get your point across or receive valid input.

Interpersonal skills such the basic courtesies factor greatly into how a crew will get along, and this will greatly impact crew effectiveness and performance.

To help prevent a loss of SA, use the "IMSAFE" guidelines. This checklist was developed for the FAA as a quick memory guide for aviators to run through and make self-determination as to their fitness to fly. If a crewmember says yes to any of these, they really shouldn't fly.

There are a number of standardized tools that can help improve CRM and overcome a loss of situational awareness. When a crew loses SA it is critical to reduce workload and threats:

- a. Suspend the mission. [Remember to "Aviate, Navigate and Communicate."]
- b. Get away from the ground and other obstacles (e.g., climb to a safe altitude).
- c. Establish a stable flight profile where you can safely analyze the situation.

Once we have lost situational awareness, or recognized the loss in another crewmember, how do we get it back?
A few methods are to:

- a. Listen to your gut feelings. If it acts like an idiot and talks like an idiot, then its probably an idiot.

- b. *Use terms like "Time Out" or "Abort" or "This is Stupid."* Once terms like these are called, the pilot should terminate the task or maneuver, climb away from the ground if necessary, establish straight-and-level flight and then discuss the problem. [The term you use should be agreed upon before the flight.]
- c. *Keep the cockpit sterile* -- keep talk to the minimum necessary for safety, particularly during taxi, takeoff, departure, low-level flying, approach, and landing. This helps remove distractions and keep everyone focused on the important things.

3. *Barriers to Communication.* Rank, gender, experience level, age, personality, and general attitudes can all cause barriers to communication. You may occasionally be hesitant to offer an idea for fear of looking foolish or inexperienced. You may also be tempted to disregard ideas that come from individuals that have a lower experience level. If you are committed to teamwork and good crew coordination, you must look through such emotions and try to constructively and sensitively adapt to each personality involved.

You can deal best with personalities by continually showing personal and professional respect and courtesy to your teammates. Criticism will only serve to build yet another barrier to good communication. Nothing breaks down a team effort faster than hostility and resentment. Always offer opinions or ideas respectfully and constructively. Instead of telling the pilot, "You're wrong," tell him what you *think* is wrong, such as "I think that new frequency was 127.5, not 127.9."

Personal factors, including individual proficiency and stress, may also create barriers to good communication. Skills and knowledge retention decrease over time, and that is why regular training is necessary. If you don't practice regularly, you very likely will spend a disproportionate amount of time on normal tasks, at the expense of communication and other tasks. Civil Air Patrol, the FAA, commercial airlines, and the military services all require certain minimum levels of periodic training for the sole purpose of maintaining proficiency.

Stress can have a very significant, negative effect on cockpit communication. An individual's preoccupation with personal, family, or job-related problems distracts him or her from paying complete attention to mission tasks and communication, depending upon the level and source of stress. The flight itself, personalities of the individuals, distractions, flight conditions, and individual performance can all be sources of communication-limiting stress. When stress reaches very high levels, it becomes an effective barrier to communication and job performance. Many fliers and medical specialists advocate refraining from flying or other complex tasks until the stress is removed.

Part of your job is also to recognize when others are not communicating and not contributing to the collective decision-making process. Occasionally, other crewmembers may need to be actively brought back into the communication process. This can often be done with a simple "What do you think about that?" In a non-threatening way, this invites the teammate back into the communication circle, and, in most cases, he or she will rejoin the information loop.

4. *Task Saturation.* At times, crews or individual members may be confronted with too much information to manage, or too many tasks to accomplish in the available time. This condition is referred to as *task saturation*. This will most likely happen when a crewmember is confronted with a new or different situation such as an emergency, bad weather, or motion sickness. Preoccupation with the different situation may then lead to a condition of "tunnel vision," where the individual can lose track of many other important conditions. In an advanced state, comprehension is so far gone that partial or complete *situational awareness* is lost. When individuals are task saturated to this extent, communication and information flow usually ceases.

If you begin to feel overwhelmed by information or the sheer number of things to do, it's time to evaluate each task and do only those tasks that are most important. If you ever feel over-tasked, you have an obligation to tell the other crewmembers *before* becoming task-saturated and losing your situational awareness. If others know your performance is suffering, they may assume some of the workload, if they are able. Once the most

important tasks are accomplished and as time permits, you can start to take back some of those tasks that were neglected earlier. Allocation of time and establishing priorities is known as *time management*.

Most people can recognize task saturation and understand how it can affect performance. However, you should also watch for these symptoms in other members of your crew and take over some of their responsibilities if you have the qualifications and can do so without placing your own duties at risk.

The pilot's job is to safely fly the aircraft, and you should be very concerned if he or she becomes task saturated, or spends an excessive amount of his time with tasks other than flying the airplane. No crewmember should ever allow the work management situation to deteriorate to such an extent as to adversely affect the pilot's ability to continue to safely operate the aircraft. Many preventable accidents have resulted from crews' entire involvement in other areas or problems, while the airplane literally flew into the ground. If any crewmember suspects pilot task saturation to be the case, nonessential discussion should cease, and the crew as a whole should discontinue low-priority aspects of the job, and even return to the mission base if necessary.

5. *Assignments and Coordination of Duties.* Assignment of aircrew duties is based on CAPR 60-3. All flight-related duties are conducted under the supervision of the aircraft commander. Mission-related duties may also be conducted under the supervision of the aircraft commander, but a properly trained observer can also fill the role of mission commander. The key is that positive delegation of monitoring duties is as important as positive delegation of flying duties. As previously discussed, it is very important for each crewmember to know what they are supposed to be doing at all times and under all conditions. Aircraft safety duties vary with the start up, taxi, takeoff, departure, transit, approach and landing phases of flight. Mission duties are related to the mission objective, primarily to fly the aircraft safely and precisely (the pilot) and to scan effectively (scanners and observers).

Close attention should be paid during the pilot's briefing. The pilot will establish flight-specific safety "bottom lines" at this time, such as emergency duties and division of responsibilities. Each individual must again clearly understand his specific assigned duties and responsibilities before proceeding to the aircraft.

Other phases of the flight also require that distractions be kept to a minimum. Recent air transport industry statistics show that 67% of airline accidents during a particular survey period happened during only 17% of the flight time -- the taxi, takeoff, departure, approach and landing phases. The FAA has designated these phases of flight as critical, and has ruled that the cockpit environment *must* be free of extraneous activity and distractions during these phases to the maximum extent possible (the sterile cockpit).

In assigning scanning responsibilities to the scanners, mission observers must be receptive to questions and suggestions from the scanners. Carefully consider suggestions and understand that suggestions are almost always offered constructively, and are not intended to be critical. Answer questions thoroughly and openly, and don't become defensive. All doubts or questions that you can't answer should be resolved as soon as possible. It is critical to remember that CRM encourages the flow of ideas, but the Mission Pilot must make the final decision based on the crew's input.

Additional Information

More detailed information on this topic is available in Chapter 14 of the MART.

Evaluation Preparation

Setup: None.

Brief Student: You are a Mission Observer trainee asked to discuss CRM.

Evaluation

Performance measures

Results

- | | | |
|--|---|---|
| 1. Discuss situational awareness and how to regain SA once it is lost. | P | F |
| 2. Describe barriers to communication. | P | F |
| 3. Discuss task saturation and strategies to minimize it. | P | F |
| 4. Discuss crew assignments and coordination of duties. | P | F |

Student must receive a pass on all performance measures to qualify in this task. If the individual fails any measure, show what was done wrong and how to do it correctly.

P-2119
DEMONSTRATE HOW TO COMPLETE A CAP AIRCRAFT INSPECTION

CONDITIONS

You are a mission pilot about to leave for a mission, and you must perform a safety inspection on your aircraft.

OBJECTIVES

Demonstrate proper performance of a CAP Aircraft Inspection (CAP Aircraft Inspection Checklist, CAPF 71).

TRAINING AND EVALUATION

Training Outline

1. Top of CAPF 71:
 - a. Date/Tach time of last 50-hour oil change, last 100-hour inspection, last Annual inspection
 - b. Wing, 'N' number, make/model/year, and current Tach time
2. Aircraft Records
3. Aircraft Interior
4. Aircraft Exterior
5. Exterior and Interior Lighting for proper operation

Additional Information

More detailed information on this topic is available in the "Instructions for use of the CAP Aircraft Inspection Checklist" (last page of the CAPF 71).

Evaluation Preparation

Setup: Ensure that an aircraft is available for the student to inspect. Copy of a current CAPF 71.

Brief Student: Demonstrate a proper CAP aircraft safety inspection.

Evaluation

<u>Performance measures</u>	<u>Results</u>
1. Demonstrate a proper aircraft safety inspection using the CAPF 71.	P F

Student must receive a pass on all performance measures to qualify in this task. If the individual fails any measure, show what was done wrong and how to do it correctly.

L-0001
BASIC COMMUNICATIONS PROCEDURES FOR ES OPERATIONS

CONDITIONS

You are a member of the CAP mission staff performing a task in which the use of a radio is necessary.

OBJECTIVES

Properly operate a CAP radio.

TRAINING AND EVALUATION

Training Information Outline

1. From time to time, duties may require the use of a CAP radio. This is not a difficult task, but does require some knowledge of operating procedures and equipment.
2. You should be able to demonstrate the following skills:
 - a. Demonstrate the proper method to contact another station.
 - b. Demonstrate knowledge of call signs.
 - c. Demonstrate knowledge of basic prowords.
 - d. Demonstrate ability to operate basic radio equipment.
 - e. Demonstrate knowledge of prohibited practices.
 - f. Demonstrate knowledge of National communications policies.
 - g. Demonstrate knowledge of local operating practices.
 - h. Demonstrate knowledge of region, wing, and local policies.

Additional Information

Additional information is available in CAPR 100-1 Vol. 1 and the "Radiotelephone Procedures Guide."

Evaluation Preparation

Setup: The student is provided with a basic radio (volume, squelch, channel controls) and asked to communicate with another station. At least one radio will be needed for this exercise. The pro-words "roger," "over," "out," affirmative," should be used. The exchange should go through several transmissions with questions and answers. Prohibitive practices, such as "chit chat," should be used or discussed.

Brief Student: The student is at mission base and has been assigned the task of reporting when the director of the local office of emergency management arrives for his/her tour of the facility.

Evaluation:

<u>Performance measures</u>	<u>Results</u>	
1. Listen before transmitting	P	F
2. Demonstrate calling procedures including call signs	P	F
3. Demonstrate use/understanding of basic prowords	P	F
4. Demonstrate understanding of radio equipment including finding local repeater/simplex	P	F

Student must receive a pass on all performance measures to qualify in this task. If the individual fails any measure, show what was done wrong and how to do it correctly.

SPECIALTY QUALIFICATION TRAINING RECORDS (SQTR)

On the following pages you will find the specialty qualification training records for the aircrew and flightline specialties. These sheets are your record of training accomplished prior to earning any of these emergency services specialty qualifications. We recommend that you keep copies of these records in a safe place just in case you lose this task guide. Electronic records are not required to be updated until all training is accomplished so this may be your only record of training successfully accomplished. Once you have completed a qualification, provide a copy of the appropriate SQTR to your unit commander or other designated officer for processing.

SPECIALTY QUALIFICATION TRAINING RECORD (SQTR)

Mission Scanner

NAME (Last, First, MI)	CAPID	DATE ISSUED
------------------------	-------	-------------

Prerequisites

Item	Date Completed
Qualified GES	
At least 18 years of age	

The above listed member has completed the required prerequisite training for the mission scanner specialty.

UNIT/WING/REGION COMMANDER OR
AUTHORIZED DESIGNEE'S SIGNATURE

DATE

Familiarization and Preparatory Training

Task	Evaluator's CAPID and Date Completed
Complete Task O-2015 Demonstrate Ground Operations and Safety	
Complete Task O-2017 Demonstrate Post-Crash Actions	
Complete Task O-2019 Demonstrate Proper Number and Character Pronunciation	
Complete Task O-2020 Use Prowords and Code Words	
Complete Task O-2021 Interpret Emergency Signals and Demonstrate Air/Ground Team Coordination	
Complete Task O-2024 Demonstrate Use of Sectional Charts	
Complete Task P-2013 Discuss Mission Scanner Duties and Responsibilities	
Complete Task P-2014 Discuss CAP Liability Coverage and Mishap Reporting	
Complete Task P-2015 Enter Data into CAP Forms	
Complete Task P-2016 Identify and Discuss Major Aircraft Controls	
Complete Task P-2017 Identify and Discuss Major Aircraft Instruments	
Complete Task P-2018 Discuss Aircraft Weight and Balance	
Complete Task P-2019 Identify Items Checked During an Aircraft Pre-Flight Inspection	
Complete Task P-2020 Discuss the Dangers of Wake Turbulence	
Complete Task P-2021 Discuss how Atmospheric and Lighting Conditions Effect Scanning Effectiveness	
Complete Task P-2022 Identify Visual Clues and Wreckage Patterns	
Complete Task P-2023 Discuss how Reduced Visibility and Turbulence Effect Search Operations	
Complete Task P-2024 Discuss Strategies to Combat High Altitude Effects	
Complete Task P-2025 Discuss Common Search Terms	
Complete Task P-2026 Identify what to Look For and Record during Damage Assessment Missions	
Complete Task P-2027 Describe CAP Search Patterns	
Complete Task P-2028 Discuss Crew Resource Management	

The above listed member has completed the required familiarization and preparatory training requirements for the (insert specialty name) specialty qualification and is authorized to serve in that specialty while supervised on training or actual missions.

UNIT/WING/REGION COMMANDER OR
AUTHORIZED DESIGNEE'S SIGNATURE

DATE

Advanced Training

Evaluator's CAPID and
Date Completed

Task

Complete Task O-0204 Locate a point on a Map using Latitude and Longitude
Complete Task O-0205 Locate a point on a Map using the CAP Grid System
Complete Task O-2016 Demonstrate Safety While Taxiing
Complete Task O-2018 Operate the Aircraft Communications Equipment
Complete Task O-2022 Demonstrate Scanning Patterns and Locate Targets
Complete Task O-2023 Demonstrate Techniques to Reduce Fatigue
Complete Task O-2025 Track and Record Position on Sectionals and Maps
Complete Task P-0101 Keep a Log
Complete the appropriate portion of CAPT 117, <i>Emergency Services Continuing Education examinations</i>

Exercise Participation

The above listed member satisfactorily participated as a mission scanner trainee under my direct supervision on mission number _____.

QUALIFIED SUPERVISOR'S SIGNATURE

DATE

The above listed member satisfactorily participated as a mission scanner trainee under my direct supervision on mission number _____.

QUALIFIED SUPERVISOR'S SIGNATURE

DATE

Unit Certification and Recommendation

The above listed member has completed the requirements for the mission scanner specialty qualification and is authorized to serve in that specialty on training or actual missions.

UNIT/WING/REGION COMMANDER OR
AUTHORIZED DESIGNEE'S SIGNATURE

DATE

SPECIALTY QUALIFICATION TRAINING RECORD (SQTR)

Mission Observer

NAME (Last, First, MI)

CAPID

DATE ISSUED

Prerequisites

Item	Date Completed
Qualified Mission Scanner	
At least 18 years of age	

The above listed member has completed the required prerequisite training for the mission observer specialty.

UNIT/WING/REGION COMMANDER OR
AUTHORIZED DESIGNEE'S SIGNATURE

DATE

Familiarization and Preparatory Training

Task	Evaluator's CAPID and Date Completed
Complete Task O-2010 Use In-Flight Services	
Complete Task O-2013 Plot a Route on a Sectional Chart	
Complete Task O-2107 Prepare for a Trip to a Remote Mission Base	
Complete Task P-2007 Discuss Mission Observer Duties and Responsibilities	
Complete Task P-2008 Discuss the Dangers of Icing	
Complete Task P-2009 Discuss the Dangers of Reduced Visibility Conditions	
Complete Task P-2010 Discuss the Dangers of Wind and Thunderstorms	
Complete Task P-2011 Discuss the Effects of Density Altitude on Aircraft Performance	
Complete Task P-2012 Identify Controlled and Special Use Airspaces on a Sectional	

The above listed member has completed the required familiarization and preparatory training requirements for the mission observer specialty qualification and is authorized to serve in that specialty while supervised on training or actual missions.

UNIT/WING/REGION COMMANDER OR
AUTHORIZED DESIGNEE'S SIGNATURE

DATE

Advanced Training

Task	Evaluator's CAPID and Date Completed
Complete Task O-2002 Operate the Aircraft Radios	
Complete Task O-2011 Operate the VOR and DME	
Complete Task O-2012 Operate the GPS	
Complete Task O-2108 Assist in ELT Searches	
Complete Task O-2109 Assist in Planning and Performing a Route Search	
Complete Task O-2110 Assist in Planning and Performing a Parallel Search	
Complete Task O-2115 Assist in Planning and Performing a Creeping Line Search	
Complete Task O-2112 Assist in Planning and Performing Point Based Searches	
Complete Basic Communications User Training	
Complete the appropriate portion of CAPT 117, <i>Emergency Services Continuing Education examinations</i>	

Exercise Participation

The above listed member satisfactorily participated as a mission observer trainee under my direct supervision on mission number _____.

QUALIFIED SUPERVISOR'S SIGNATURE

DATE

The above listed member satisfactorily participated as a mission observer trainee under my direct supervision on mission number _____.

QUALIFIED SUPERVISOR'S SIGNATURE

DATE

Unit Certification and Recommendation

The above listed member has completed the requirements for the mission observer specialty qualification and is authorized to serve in that specialty on training or actual missions.

UNIT/WING/REGION COMMANDER OR
AUTHORIZED DESIGNEE'S SIGNATURE

DATE

SPECIALTY QUALIFICATION TRAINING RECORD (SQTR)

Mission Pilot

NAME (Last, First, MI)

CAPID

DATE ISSUED

Prerequisites

Item	Date Completed
Qualified Mission Scanner	
Current and qualified CAP pilot in accordance with CAPR 60-1, with at least 175 hours pilot in command time including 50 hours of cross-country flying	
At least 18 years of age	

The above listed member has completed the required prerequisite training for the mission pilot specialty.

UNIT/WING/REGION COMMANDER OR
AUTHORIZED DESIGNEE'S SIGNATURE

DATE

Familiarization and Preparatory Training

Task	Evaluator's CAPID and Date Completed
Complete Task O-2003 Grid Sectional Charts	
Complete Task O-2004 Use a POD Table	
Complete Task O-2009 Demonstrate Air/Ground Team Coordination Techniques	
Complete Task O-2101 Describe how ELTs are Detected	
Complete Task P-2001 Discuss Mission Pilot Duties and Responsibilities	
Complete Task P-2002 Discuss General CAP-Related Safety Requirements and Issues	
Complete Task P-2003 Discuss Types of Flights Performed by CAP Aircrews	
Complete Task P-2004 Discuss Security Concerns and Procedures	
Complete Task P-2005 Discuss Mission Pilot Responsibilities During a Mission	
Complete Task P-2028 Discuss Crew Resource Management	

The above listed member has completed the required familiarization and preparatory training requirements for the mission pilot specialty qualification and is authorized to serve in that specialty while supervised on training or actual missions.

UNIT/WING/REGION COMMANDER OR
AUTHORIZED DESIGNEE'S SIGNATURE

DATE

Advanced Training

Evaluator's CAPID and
Date Completed

Task

Complete Task O-2001 Operate the Aircraft Audio Panel	
Complete Task O-2005 Operate the Aircraft DF	
Complete Task O-2006 Perform ELT Searches	
Complete Task O-2007 Locate and Silence an ELT on the Ground	
Complete Task O-2008 Complete a Mission Sortie	
Complete Task O-2102 Demonstrate Planning and Flying a Route Search	
Complete Task O-2103 Demonstrate Planning and Flying a Parallel Track Search	
Complete Task O-2104 Demonstrate Planning and Flying a Creeping Line Search	
Complete Task O-2105 Demonstrate Planning and Flying a Point Based Search	
Complete Task O-2106 Plan and Command a CAP Flight	
Complete Task O-2107 Prepare for a Trip to a Remote Mission Base	
Complete Task P-2119 Demonstrate how to complete a CAP aircraft inspection	
Complete CAPF 91 Check Ride	
Complete Basic Communications User Training	
Complete the appropriate portion of CAPT 117, <i>Emergency Services Continuing Education examinations</i>	

Exercise Participation

The above listed member satisfactorily participated as a mission pilot trainee under my direct supervision on mission number _____.

QUALIFIED SUPERVISOR'S SIGNATURE DATE

The above listed member satisfactorily participated as a mission pilot trainee under my direct supervision on mission number _____.

QUALIFIED SUPERVISOR'S SIGNATURE DATE

Unit Certification and Recommendation

The above listed member has completed the requirements for the mission pilot specialty qualification and is authorized to serve in that specialty on training or actual missions.

UNIT/WING/REGION COMMANDER OR
AUTHORIZED DESIGNEE'S SIGNATURE DATE

SPECIALTY QUALIFICATION TRAINING RECORD (SQTR)
Flight Line Marshaller

NAME (Last, First, MI)	CAPID	DATE ISSUED
------------------------	-------	-------------

Prerequisites

Item	Date Completed
Qualified GES	

The above listed member has completed the required prerequisite training for the flightline marshaller specialty.

UNIT/WING/REGION COMMANDER OR
 AUTHORIZED DESIGNEE'S SIGNATURE

DATE

Familiarization and Preparatory Training

Task	Evaluator's CAPID and Date Completed
Complete Task O-3001 Discuss Flightline Marshallers Responsibilities	
Complete Task O-3002 State the Five Flight Line Safety Precautions	
Complete Task O-3003 Identify Requirements for Vehicles on the Flightline	
Complete Task O-3004 Discuss Flight Line Security	
Complete Task O-3005 Discuss Flight Line Hazards	

The above listed member has completed the required familiarization and preparatory training requirements for the flightline marshaller specialty qualification and is authorized to serve in that specialty while supervised on training or actual missions.

UNIT/WING/REGION COMMANDER OR
 AUTHORIZED DESIGNEE'S SIGNATURE

DATE

Advanced Training

Task	Evaluator's CAPID and Date Completed
Complete Task O-3006 Marshall an aircraft	
Complete Task O-3007 Be a Wing Walker	
Complete Task O-3008 Perform Aircraft Startup Procedures	
Complete Task O-3009 Perform aircraft taxi procedures	
Complete Task O-3010 Perform Aircraft Shutdown and Chocking Procedures	
Complete Task O-3011 Tie Down an Aircraft	
Complete Task O-3012 Demonstrate Proper Ground Safety Observer Techniques	
Complete Task O-3013 Demonstrate the Ability to Fuel an Aircraft	
Complete Task O-3014 Demonstrate knowledge of flight line security	
Complete Basic First Aid Training or equivalent	
Complete Basic Communications User Training	
Complete Task L-0001 Basic Communications Procedures for ES Operations	
Complete the appropriate portion of CAPT 117, <i>Emergency Services Continuing Education examinations</i>	

Exercise Participation

The above listed member satisfactorily participated as a flightline marshaller trainee under my direct supervision on mission number _____.

QUALIFIED SUPERVISOR'S SIGNATURE

DATE

The above listed member satisfactorily participated as a flightline marshaller trainee under my direct supervision on mission number _____.

QUALIFIED SUPERVISOR'S SIGNATURE

DATE

Unit Certification and Recommendation

The above listed member has completed the requirements for the flightline marshaller specialty qualification and is authorized to serve in that specialty on training or actual missions.

UNIT/WING/REGION COMMANDER OR
AUTHORIZED DESIGNEE'S SIGNATURE

DATE

**SPECIALTY QUALIFICATION TRAINING RECORD (SQTR)
Flightline Supervisor**

NAME (Last, First, MI)	CAPID	DATE ISSUED
------------------------	-------	-------------

Prerequisites

Item	Date Completed
Qualified GES	
Qualified Flightline Marshaller	
At least 18 years of age	

The above listed member has completed the required prerequisite training for the flightline supervisor specialty.

UNIT/WING/REGION COMMANDER OR
AUTHORIZED DESIGNEE'S SIGNATURE

DATE

Familiarization and Preparatory Training

Task	Evaluator's CAPID and Date Completed
Complete NIIMS G193 or equivalent	
Complete Task O-3101 Demonstrate knowledge of the flight line supervisor's responsibilities	
Complete Task O-3102 Discuss How to Set Up a Flight Line	
Complete Task O-3103 Discuss Flight Line Organization	

The above listed member has completed the required familiarization and preparatory training requirements for the flightline supervisor specialty qualification and is authorized to serve in that specialty while supervised on training or actual missions.

UNIT/WING/REGION COMMANDER OR
AUTHORIZED DESIGNEE'S SIGNATURE

DATE

Advanced Training

Task	Evaluator's CAPID and Date Completed
Complete Task O-3104 Coordinate Activities with Local FBO	
Complete Task O-3105 Coordinate Activities with Airport Administration and Security	
Complete Task O-3106 Coordinate Activities With Local Fire Department	
Complete Task O-3107 Coordinate Activities With Local Hospital and/or EMT Operators	
Complete Task O-3108 Survey Airport for the Best Parking Areas and Taxi Routes	
Complete Task O-3109 Survey Airport for Hazards and Emergency Equipment	
Complete Task O-3110 Demonstrate the ability to supervise the flight line marshallers	
Complete Task O-3111 Brief Flight Line Marshallers and trainees	
Complete Task O-3112 Demonstrate the ability to Tow and Park an Aircraft	
Complete Task O-3113 Refuel an Aircraft	
Complete Task O-3114 Keep Track of Aircraft Refueling	
Complete Task O-3115 Discuss Helicopter Operations	
Complete Task P-0101 Demonstrate the ability to keep a log	
Complete the appropriate portion of CAPT 117, <i>Emergency Services Continuing Education examinations</i>	

Exercise Participation

The above listed member satisfactorily participated as a flightline supervisor trainee under my direct supervision on mission number _____.

QUALIFIED SUPERVISOR'S SIGNATURE

DATE

The above listed member satisfactorily participated as a flightline supervisor trainee under my direct supervision on mission number _____.

QUALIFIED SUPERVISOR'S SIGNATURE

DATE

Unit Certification and Recommendation

The above listed member has completed the requirements for the flightline supervisor specialty qualification and is authorized to serve in that specialty on training or actual missions.

UNIT/WING/REGION COMMANDER OR
AUTHORIZED DESIGNEE'S SIGNATURE

DATE

COMMENTS AND SUGGESTIONS

Task based training will be new to personnel at all levels. If you have any questions in reference to this task guide please forward them to:

HQ CAP/DOS
105 South Hansell Street, Bldg 714
Maxwell AFB, AL 36112-6332

Fax: (800) 555-7902
E-mail: dos@cap.gov

Operations are continually changing which requires changes to CAP training materials. In accordance with CAPR 60-3, recommended changes to task guides for all specialties will be submitted through the chain of command to the Region Commander. If the Region Commander concurs with the proposed change, he/she will forward the recommendation to NHQ CAP/DO. NHQ will forward the recommendation to all Region Commanders for their consideration. Proposals that are approved by a majority of the Region Commanders will be incorporated into the standardized National task guides.